

# Blaze King

## TORINO II 1606

FREESTANDING DIRECT VENTED GAS ROOM HEATER  
for use with natural gas or LPG



### OPERATION & INSTALLATION MANUAL



**Installer:** Please complete the details on the back cover and leave this manual with the homeowner.  
**Homeowner:** Please keep these instructions for future reference.

**WARNING:** If the information in these instructions are not followed exactly, a fire or explosion may result causing property damage, personal injury or loss of life.

- Do not store or use gasoline or other flammable vapors and liquids in the vicinity of this or any other appliance.
- WHAT TO DO IF YOU SMELL GAS
  - Do not try to light any appliance.
  - Do not touch any electrical switch; do not use any phone in your building.
  - Immediately call your gas supplier from a neighbor's phone. Follow the gas supplier's instructions.
  - If you cannot reach your gas supplier, call the fire department.
- Installation and service must be performed by a qualified installer, service agency or the gas supplier.

This appliance may be installed in an aftermarket, permanently located, manufactured (mobile) home, where not prohibited by local codes.

This appliance is only for use with the type of gas indicated on the rating plate. This appliance is not convertible for use with other gases, unless a certified kit is used.

### **WARNING**



**HOT GLASS WILL CAUSE BURNS.**  
**DO NOT TOUCH GLASS UNTIL COOLED.**  
**NEVER ALLOW CHILDREN TO TOUCH GLASS.**

Pour la version française de nos manuels S.V.P. vous référez à notre site web: [www.blazeking.com](http://www.blazeking.com)

## Table of Contents

INTRODUCTION _____	3
CERTIFICATION LABEL _____	4
GENERAL INFORMATION _____	5
APPLIANCE DIMENSIONS _____	7
INSTALLATION CLEARANCES _____	8
ASSEMBLY INSTRUCTIONS _____	9
INSTALLATION INSTRUCTIONS _____	11
RIGID VENTING PARTS LIST _____	20
INTERMITTENT PILOT & VALVE _____	23
WIRING DIAGRAM _____	25
LIGHTING INSTRUCTIONS _____	26
THERMOSTAT REMOTE CONTROL _____	27
MAINTENANCE _____	32
SERVICING _____	34
FUEL CONVERSION _____	35
BURNER TRAY REMOVAL AND INSTALLATION _____	37
VALVE REMOVAL AND INSTALLATION _____	38
FAN REMOVAL AND INSTALLATION _____	39
ALLOWABLE TERMINATION LOCATIONS _____	40
TROUBLESHOOTING _____	41
REPLACEMENT PARTS _____	43
WARRANTY _____	45
NOTES _____	49

### Manufactured By

**Valley Comfort Systems Inc.**

1290 Commercial Way  
 Penticton, BC V2A 3H5  
 CANADA  
 Phone: 250-493-7444  
 Fax: 250-493-5833

**Blaze King Industries**

146 A Street  
 Walla Walla, WA 99362  
 U.S.A.  
 Phone: (509) 522-2730  
 Fax: (509) 522-9803

## INTRODUCTION

### To Our Valued Customers

Dear Customer:

Thank you for purchasing a Torino II Gas Heater.

The Torino II is one of the most advanced direct vented gas heaters on the market. It is designed using the latest technology and manufactured to the highest quality.

This owner's manual explains the steps required to safely assemble, install, operate, and maintain your new heater. Please carefully read these requirements for safe installation and proper operation before installing and using your heater.

Obtain permits from the Building Inspector or Fire Department, if local laws require. Check local building and fire codes before installing your heater. When you have completed the installation, have it checked by your local inspector. Disregarding inspection and code requirements may jeopardize your homeowner's insurance. Since some insurance carriers require notification of a stove installation, contact your insurance agent. We want your Blaze King to give you a lifetime of trouble-free operation.

While we have made every effort to make these instructions as complete as possible, some installation or operating conditions may not be covered. If you have any questions that are not answered here, contact your Blaze King dealer, Local Building Inspector, Fire Department, or our customer service department at Blaze King. In the USA please call (509)-522-2730 or in Canada please call (250)-493-7444.

The Management and Employees of

*Blaze King Industries, Inc*

## CERTIFICATION LABEL



**Intertek**

Certified for U.S. and Canada  
Certifié pour le Canada et les Etas - US

ANSI Z21.88-2009/CSA 2.33-2009, "Vented Gas Fireplace Heaters", CAN/CGA 2.17-M91 "Gas-Fireplaces For Use At High Altitudes."

Test é à ANSI Z21.88-2009/CSA 2.33-2009 "Foyer au gaz avec éventet", CAN/CGA 2.17-M91 "Appareils de chauffage au gaz utilisés en hautes altitudes"

Listed Vented Gas Fireplace Heater / Foyer chauffé au gaz avec évent  
**Torino II Free Standing W/N #16960**

Serial No. -

This stove is factory equipped for 0-1370 m (0-4500 ft)  
Ce foyer est manufacturée et équipé pour 0-1370 m (0-4500 pied)

Model: Torino II top vent appliance Modèle: Torino II appareil à évent en haut Orifice (DMS) 0-1370 m	<input type="checkbox"/>	NATURAL GAS 36	<input type="checkbox"/>	LP GAS 52
Input rating / Puissance d'entrée (BTU/hr / Kw) 0-1370m 0-4500 ft Alt.		30,500 / 8.94		30,500 / 8.94
Minimum Input / Entrée Minimum (BTU/hr / Kw)		20,600 / 6.04		17,200 / 5.04
Manifold Pressure High Setting (In w.c. / kPa)		3.5 / 0.87		11.0 / 2.74
Manifold Pressure Lo Setting (In w.c. / kPa)		1.6 / 0.40		2.9 / .72
Minimum Inlet Pressure / Pression d'entrée Minimum (In w.c. / kPa)		7.0 / 1.74		11.0 / 2.74

This appliance must be installed in accordance with local codes if any: if not follow ANSI Z223.1 and CAN 1-B149 Gas Appliance Installation Code ANSI Z223.1 / NFPA 54 or Natural Gas and Propane Installation Codes CSA B149.1. Cet appareil doit être installé selon les codes locaux, s'il y en a: sinon suivez l'actuel ANSI Z223.1 et CAN 1-B149 Appareil au Gaz Code ANSI Z223.1 / NFPA 54 ou Gas Naturel et Propane CSA B149.1.

### VENTED GAS FIREPLACE HEATER—NOT FOR USE WITH SOLID FUEL

### FOYER AU GAZ AVEC ÉVENT—NE PAS UTILISER AVEC DU COMBUSTIBLE SOLIDE

FOR USE WITH GLASS DOORS CERTIFIED WITH THE APPLIANCE ONLY. / UTILISER SEULEMENT AVEC DES PORTES VITRÉES CERTIFIÉES POUR CET APPAREIL.

ALSO FOR USE IN OEM / MOBILE (MANUFACTURED) HOMES AFTER HOME IS ON SITE. Convertible for use with natural gas or propane as follows: For natural gas when equipped with orifice # 36, for propane when equipped with orifice # 52.

MAY BE INSTALLED IN A BEDROOM OR SITTING ROOM WHEN INSTALLED WITH A LISTED THERMOSTAT CONTROL IN CANADA.

AUSSI POUR L'USAGE DANS LES MAISONS (MANUFACTURÉES) MOBILES APRÈS QUE LA MAISON SE TROUVE SUR LE CHANTIER. Convertible pour l'usage avec le gaz naturel ou le propane comme suit: Pour le gaz naturel une fois équipé de l'orifice # 36, pour le propane une fois équipé de l'orifice # 52.

PEUT ÊTRE INSTALLÉ DANS UNE CHAMBRE À COUCHER OU UN SALON UNE FOIS INSTALLÉ AVEC UN THERMOSTAT ÉNUMÉRÉ AU CANADA.

### MINIMUM CLEARANCES TO COMBUSTIBLES / ESPACES MINIMUM REQUIS ENTRE L'APPAREIL ET DES MATÉRIEAUX COMBUSTIBLES.

Unit to Sidewall / Unité au mur à l'atéral	254 mm (10 in)	Unit to Back wall / Unité au mur arrière	152 mm (6 in)
Floor / Plancher	Unprotected (in Canada) / Sans protection (Canada)		
Floor / Plancher	Unprotected (in U.S.A.) / Sans protection (U.S.A.)		
Vent pipe / Event (vertical)	25 mm (1 in)		

Electrical Rating: 115 Volts, 0.7 Amp, 60 Hz

**DANGER: Risk of electrical shock. Disconnect power before servicing unit. Do not route power cord beneath heater.**

**DANGER: Risque d'électrocution. Débrancher le courant avant de réparer l'unité. Ne pas mettre la corde d'alimentation en dessous de l'appareil de chauffage.**

This appliance must be installed in accordance with the Standard CAN/CSA Z240 MH, Mobile Housing, in Canada, or with the Manufactured Home Construction and Safety Standard, Title 24 CFR, Part 3280, in the United States, or when such a standard is not applicable, ANSI/NCSBSCS A225.1/NFPA 501A, Manufactured Home Installations Standard. / Cet appareil doit être installé selon les codes CAN/CSA Z240 MH, maisons (manufacturées) mobiles, au Canada, sinon applicable, utilisez ANSI/NCSBSCS A225.1/NFPA 501A, Manufactured Home Installations Standard.

This appliance is only for use with the type of gas indicated on the rating plate and may be installed in an aftermarket, permanently located, manufactured (mobile) home where not prohibited by local codes. See owners manual for details. This appliance is not convertible for use with other gases unless a certified kit is used. This vented gas fireplace is not for use with air filters.

Cet appareil sert seulement avec le type de gaz indiqué sur la plaque de contrôle et peut être installé dans un marché des accessoires, maison (mobile) de manière permanente placée et manufacturée où non interdit par des codes locaux. Voir le manuel d'installation pour des détails. Cet appareil n'est pas convertible pour l'usage avec d'autres gaz à moins qu'un kit certifié soit employé. Ce foyer au gaz à évent ne peut être utilisé avec des filtres à air.

### MINIMUM ALCOVE CLEARANCES

A	Side Wall to unit side	10" (254 mm)
B	Back Wall to unit side	6" (152 mm)
C	Corner to Side Wall	4 3/8" (111 mm)
	Minimum Alcove Height	48" (1219 mm)

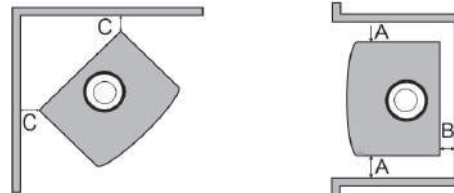

Manufactured in U.S.A. by: **Blaze King Industries**  
146 A Street, Walla Walla, WA  
U.S.A. 99362

Manufactured in Canada by: **Valley Comfort Systems Inc.**  
1290 Commercial Way, Penticton, B.C.  
Canada V2A 3H5

MANUFACTURE DATE					
JAN <input type="checkbox"/>	FEB <input type="checkbox"/>	MAR <input type="checkbox"/>	APR <input type="checkbox"/>	MAY <input type="checkbox"/>	JUN <input type="checkbox"/>
JUL <input type="checkbox"/>	AUG <input type="checkbox"/>	SEP <input type="checkbox"/>	OCT <input type="checkbox"/>	NOV <input type="checkbox"/>	DEC <input type="checkbox"/>
2012 <input type="checkbox"/>	2013 <input type="checkbox"/>	2014 <input type="checkbox"/>	2015 <input type="checkbox"/>	2016 <input type="checkbox"/>	2017 <input type="checkbox"/>

#0375ef1012.indd

## GENERAL INFORMATION

### APPLIANCE CERTIFICATION

This appliance is tested and certified to the following US and Canadian gas appliance standards:

- ANSI Z21.88b-2007 / CSA 2.33b-2007 Vented Gas Fireplace Heaters,
- CAN/CGA-2.17-M91 Gas-Fired Appliance for Use at High Altitudes
- CSA P.4.1-02 Testing Method for Measuring Annual Fireplace Efficiency

Please contact Valley Comfort or Blaze King, if you have any questions regarding the certification of this appliance.

- The installation must conform with the local codes or, in the absence of local codes, with the current National Fuel Gas Code, ANSI Z223.1/ NFPA 54, in the US or Installation Code, CSA-B149.1, in Canada.
- A manufactured home (USA only) or mobile home OEM installation must conform with the Manufactured Home Construction and Safety Standard, Title 24 CFR, Part 3280, or, when such a standard is not applicable, the Standard for Manufactured Home Installations, ANSI/NCSBCS A225.1, or Standard for Gas Equipped Recreational Vehicles and Mobile Housing, CSA Z240.4.
- The appliance and its appliance main gas valve must be disconnected from the gas supply piping system during any pressure testing of that system at test pressures in excess of 1/2 psi (3.5 kPa).
- This gas appliance must not be connected to a chimney flue serving a separate solid-fuel burning appliance.
- The appliance, when installed, must be electrically grounded in accordance with local codes or, in the absence of local codes, with the National Electrical Code, ANSI/NFPA 70, in the US, or the Canadian Electrical Code, CSA C22.1, in Canada.
- Do not use this appliance if any part has been under water. Immediately call a qualified service technician to inspect the appliance and to replace any part of the control system and any gas control which has been under water.
- Caution: Label all wires prior to disconnection when servicing controls. Wiring errors can cause improper and dangerous operation. Verify proper operation after servicing.

## GENERAL INFORMATION cont.

### CAUTION

- Due to high temperatures, the appliance should be located out of traffic and away from furniture and draperies.
- Children and adults should be alerted to the hazards of high surface temperature and stay away to avoid burns or clothing ignition.
- Young children should be carefully supervised when they are in the same room as the appliance.
- Clothing or other flammable material should not be placed on or near the appliance.
- Installation and repair should be done by a qualified service person. The Appliance should be inspected before use and at least annually by a professional service person. More frequent cleaning may be required due to excessive lint from carpeting, bedding material, etcetera. It is imperative that control compartments, burners and circulating air passageways of the appliance be kept clean.

### INSTALLATION CODES

This appliance must be installed by a qualified gas appliance installer. This appliance is certified for installation in a bedroom or a bedsitting room. This appliance is only for use with the type of gas indicated on the rating plate and may be installed in an aftermarket, permanently located, manufactured (mobile) home where not prohibited by local codes. This appliance is not convertible for use with other gases, unless a certified kit is used. Only for direct discharge without duct connection. This appliance must be direct vented using listed and approved Simpson Dura-Vent, Selkirk, Security or American Metal Products vent components.

### SPECIFICATIONS

<b>MODEL Torino II</b>	<b>Natural Gas (NG)</b>	<b>Propane (LPG)</b>
Manifold Pressure	3.5 in. w.c. (0.87kPa)	11.0 in. w.c. (2.74 kPa)
Min. Supply Pressure for Purpose of Input Adjustment	7 in. w.c. (1.74 kPa)	11.0 in. w.c. (2.74 kPa)
Orifice Size	DMS # 36	DMS # 52
Nominal Input Rating	30,500 BTU/hr	30,500 BTU/hr
Minimum Input Rating	20,600 BTU/hr	17,200 BTU/hr
Altitude	0 - 4,500 ft. (0 - 1372 m)	0 - 4,500 ft. (0 - 1372 m)
Primary Air Opening	50% (Minimum)	open
Electrical Rating	120 V.A.C. System	120 V.A.C. System

### HIGH ALTITUDE INSTALLATION

When installing this appliance beyond 4500 ft. (1372 m) above sea level, the appliance must be properly de-rated and installed according to local codes, in the absence of local codes, with the current National Fuel Gas Code, ANSI Z223.1/ NFPA 54, in the US or Installation Code, CSA-B149.1, in Canada.

APPLIANCE DIMENSIONS

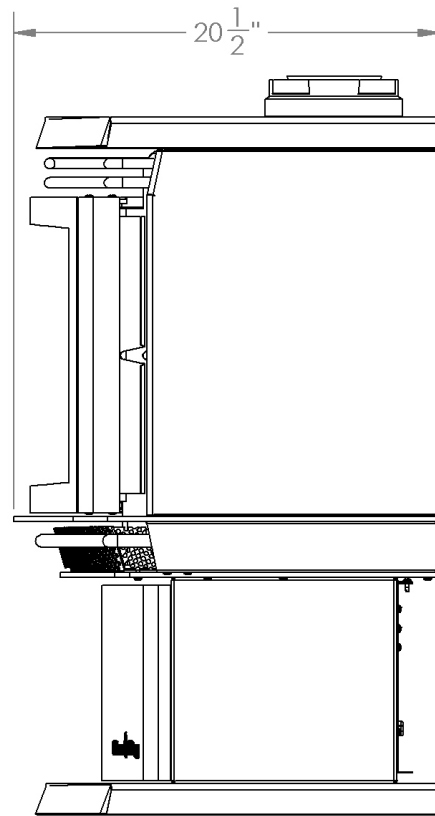
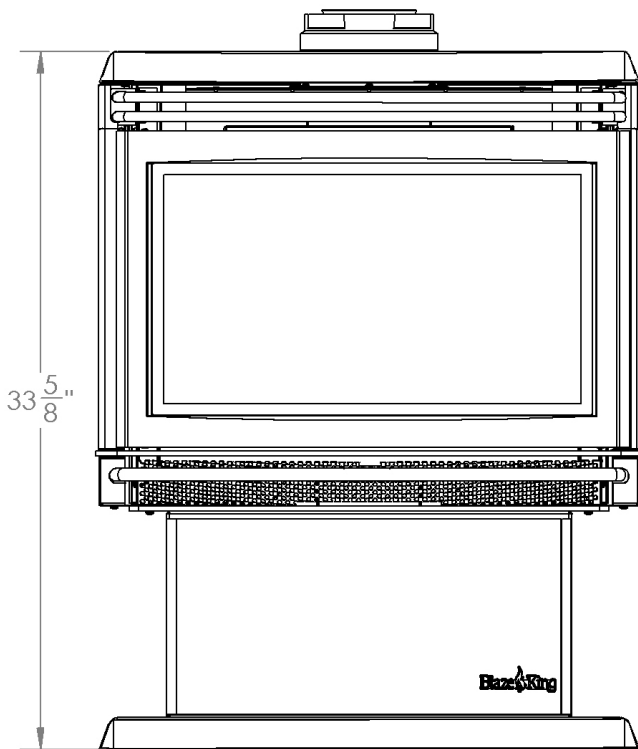
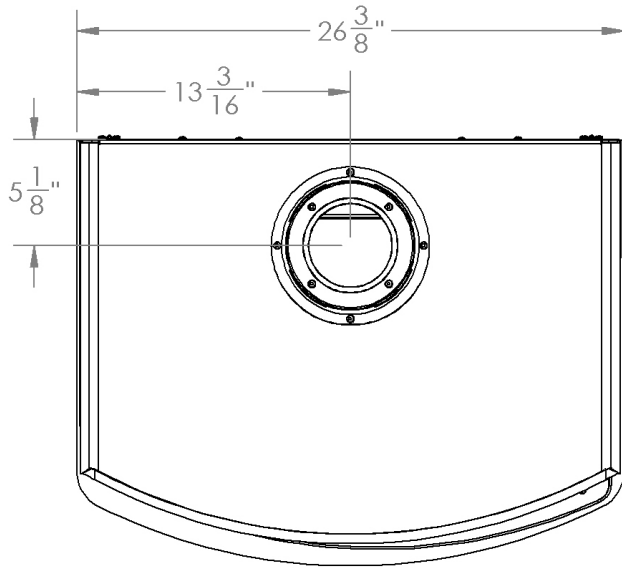



## INSTALLATION CLEARANCES

### CLEARANCES TO COMBUSTIBLES

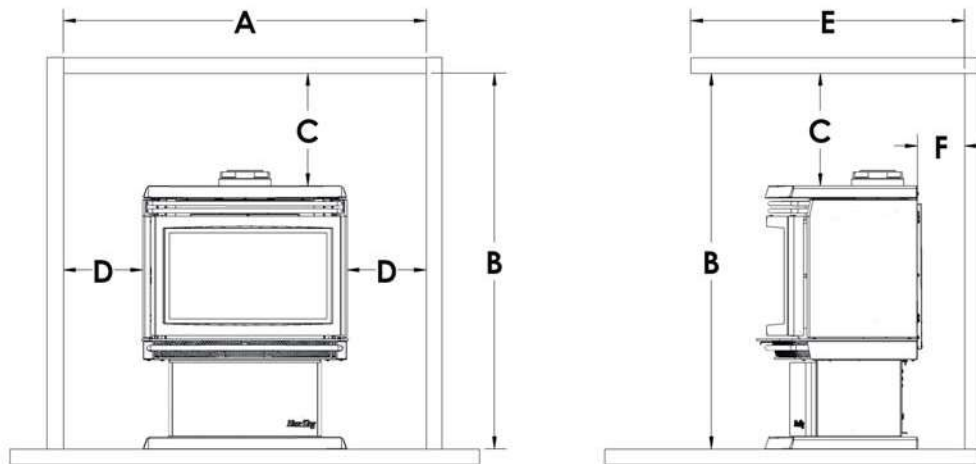

**Fig.2**

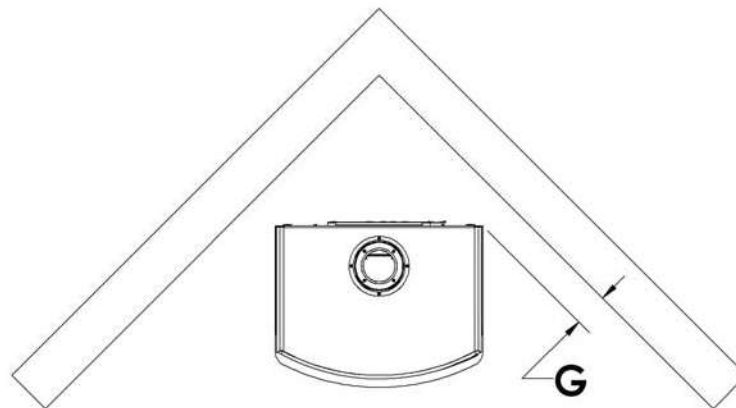

MODEL - Torino II		
A	Alcove Width	min. 46-3/8" (1178 mm)
B	Alcove Height	min. 48" (1219 mm)
C	Top of Unit to Alcove Ceiling	min. 12-1/2" (318 mm)
D	Side of Unit to Sidewall	min. 10" (254 mm)
E	Alcove Depth	max. 37" (940mm)
F	Back of Unit to Back Wall	min. 6" (152mm)
G	Corner of Unit to Side Wall	min. 4-3/8" (111 mm)
Vent		1" (25 mm) to outside surface

**Note: Check local codes for floor requirements.**

**This fireplace is suitable for installation on a combustible surface.**



## ASSEMBLY INSTRUCTIONS

### GLASS DOOR REMOVAL

#### Removing the Glass Door:

1. Open the right side panel.
2. Unhook the door latch.
3. Swing the door open.
4. Using a screw driver, remove the top glass retainer, making sure to hold the glass from falling out.
5. Lift out and remove door glass with the gasket attached.
6. If the glass door is damaged, it must be replaced with another glass door certified with this appliance only
7. Replacement glass doors are available through your Blaze King dealer see "REPLACEMENT PARTS" on page 43

#### Replacing the Glass Door:

1. Check the condition of the glass and the gasket before installing door.
2. Replace the window glass and gasket and re-install the top glass retainer.
3. Swing the door shut and re-attached the door latch.

If the glass has been damaged contact your dealer and replace the glass and gasket with a new glass and gasket provided by your dealer.

#### WARNING:

- Do not use any substitute materials for glass components.
- Do not abuse glass door such as striking or slamming shut.
- Do not operate this appliance with cracked or broken glass.
- Clean glass with a soft, non-abrasive cloth and water or a suitable, mild, non-abrasive cleaner.
- Do not use abrasive cleaners.
- Do not clean or remove glass when the appliance is hot.

#### WARNING:

Do not operate appliance with the glass front removed, cracked or broken. Replacement of the glass should be done by a licensed or qualified service person.

## ASSEMBLY INSTRUCTIONS cont.

### PLACEMENT OF LOGS



Step 1: Place rear log on log on pins near the rear center of the burner.



Step 3: Install pins in holes “arrows” and place final log on pins as shown.



Step 2: Install pins in holes “arrows” and place next log on pins and log support.



### INTERMITTENT PILOT FLAME

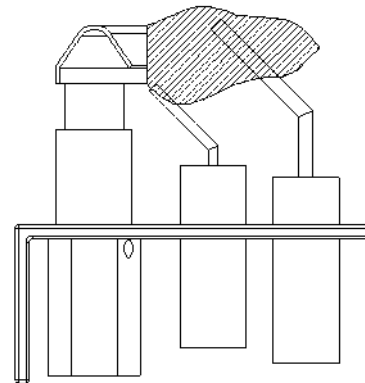

Fig. 3

#### WARNING :

Do not place the logs in any other configuration than the one shown.  
Fire, explosion or excessive carbon monoxide (CO) may result,  
causing property damage, personal injury or loss of life.

## INSTALLATION INSTRUCTIONS

### PRECAUTIONS

- This appliance must be installed by a qualified gas installer and the installation conform to the installation codes.
- This appliance needs fresh air for safe operation and must be installed so there are provisions for adequate ventilation air. Provide adequate clearance around air openings of the appliance. Never obstruct front openings.
- Provide adequate clearances for proper operation and servicing of the appliance.
- This appliance must be properly connected to a venting system.
- This appliance must NOT be connected to a chimney flue serving a solid-fuel appliance.

### LOCATING GAS FIREPLACE

The venting system of this appliance must be installed in a location that is free of plumbing, electrical wiring and heating or air conditioning ducts. Select a location that is accessible for venting. See “ALLOWABLE TERMINATION LOCATIONS” on page 40, in this manual.

### Mobile Home Installation:

Two holes are provided in the pedestal base of the unit to allow for anchoring down the appliance. To access the mounts simply remove the pedestal back panel, or lift off the pedestal valve access panel at the front of the unit. The pedestal back unscrews with 4 screws, the pedestal front lifts off 2 hooks and 2 magnets. Lift up and pull towards you.

### VENT TERMINATION LOCATION

1. Establish a suitable vent termination location, see “ALLOWABLE TERMINATION LOCATIONS” on page 40
2. In heavy snowfall areas make sure vent termination is located where it can not be blocked by snowfall or snow from snow removal equipment.
3. Locate vent termination away from plants, bushes or any other object on or near the vent termination that will interfere or obstruct the air flow around it.
4. DO NOT recess vent termination into walls, sidings or planters.
5. Vent terminations located below 7 ft (2130 mm) from grade level or anywhere that it is a burn hazard to the public, such as patios and balconies, must be protected with an approved termination cage.

## INSTALLATION INSTRUCTIONS cont.

### GAS CONNECTIONS

Have your gas supplier or a qualified gas fitter run a gas supply line into the gas fireplace. The line must be properly sized and fitted according to the installation codes. Upstream of the supply connection, the fitter shall provide a manual shut-off valve.

#### **CAUTION:**

The appliance and its individual shutoff valve must be disconnected from the gas supply piping system during any pressure-testing of that system at test pressures in excess of 1/2 psig (3.5 kPa). The appliance must be isolated from the gas supply piping system by closing its individual manual shutoff valve during any pressure-testing of the gas supply piping system at test pressures equal to or less than 1/2 psig (3.5 kPa). Failure to do so will damage the appliance's gas valve. Such damage is not cover by the manufacturer's warranty.

- Check for proper gas supply pressure by loosening the set screw on supply pressure tap on the gas valve with a small flat tip screw driver and placing a test gauge on the tap.
- Check for proper gas supply pressure by loosening the set screw on supply pressure tap on the gas valve with a small flat tip screw driver and placing a test gauge on the tap.
- The minimum permissible gas supply pressure is 5.0 in. w.c. (1.24 kPa) for natural gas and 12.0 in. w.c. (3.0 kPa) for propane. Maximum gas supply pressure should never exceed 14.0 in. w.c. (3.48 kPa) or 1/2 psi. for both natural gas and propane.

### **BE SURE TO TIGHTEN THE PRESSURE TAP SET SCREW AFTER CHECKING THE PRESSURE.**

Before connecting the appliance to the gas supply line, double check that the appliance you have purchased is designed for the gas type you are using. The gas type markings are located on the certification label and also on the appliance's gas valve.

Adequate clearance for proper installation and checking of the gas connections must be provided. All gas connections must be checked for gas leaks.

#### **Pedestal Access**

The pedestal / gas controls can be accessed for set up or servicing and adjusting. The pedestal rear cover can be removed with 4 screws, while the front lifts off 2 hooks and magnets. Use care when removing these parts that you do not accidentally scratch the paint on the pedestal base. When the covers are removed, you should have easy access for connections and testing purposes. Re-install these components after servicing, again, being careful not to damage the painted services of the stove.



## INSTALLATION INSTRUCTIONS cont.

### WARNING:

A minimum clearance of 1" to combustibles must be maintained on vertical pipe runs and 2" for horizontal pipe runs (sides and bottom 1")

The rigid vent systems use twist lock connections. The adaptor attached to the unit connects to the approved venting system. While you are assembling the pipe bear in mind the best visual appearance. Seams should be aligned and hidden as much as possible. Make sure you twist the mating section all the way to make a solid connection.

### As this system is a sealed system, a high temperature sealing compound must be used to seal the metal to metal joint:

Apply a bead of high temperature sealant to both the 4" exhaust and 6-5/8" intake section of the male pipe. The female section of the pipe/fitting has four indentations evenly spaced around the pipe. These indentations are designed to slide over the male section of the pipe and locate into the four entry slots of the male section of pipe. Twist the female section clockwise a quarter turn to fully lock the sections together.

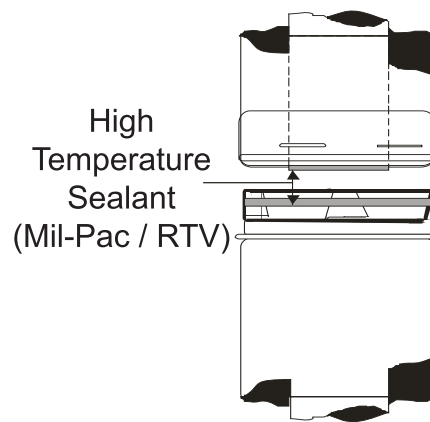

### Horizontal Wall Vent Terminations

The position of the horizontal vent termination must be positioned to meet all local building codes, see "ALLOWABLE TERMINATION LOCATIONS" on page 40. Attach the correct length of vertical section pipe and an elbow fitting to the stove. Mark the center line of the pipe facing the wall (allowing for a 1/4" rise per foot of horizontal run). Example 10 ft of horizontal would require a rise of 2.5".

**NOTE: Allowing the vent pipe to slope down towards the vent termination could cause poor combustion and/or high temperatures that may present a fire hazard.**

Mark a 10" x 10" square around the center mark (inside dimensions). Cut and frame the exterior wall to accept the wall penetration heat shield. Install the penetration shield using wood screws. If the wall being penetrated is constructed of non-combustible material a 7" hole sufficient for the vent pipe, is acceptable.

**CAUTION: When installing the termination on to vinyl siding, a vinyl siding kit must be used. This prevents the termination from being recessed into the siding.**

When the termination is to be attached to vinyl siding apply a bead of non-hardening mastic around the outside edge to form a seal between the standoff and the termination cap. Attach the termination cap to the exterior wall inserting four wood screws through the holes in the corner of the vent termination. Complete the installation by applying a bead of mastic around the outer edge of the vinyl standoff.

With the termination cap installed you can now connect the completed vent assembly by sliding the unit back towards the wall and carefully inserting the pipe into the terminal. Before the final connection is made slide on the decorative wall thimble. Secure the termination cap by securing the termination straps to the pipe as close to the exterior wall as possible using sheet metal screws. Ensure that the straps are hidden by the wall thimble cover. Apply decorative trim if required.

**INSTALLATION INSTRUCTIONS cont.****Vertical Installations**

Always maintain the 1" clearance around the vent pipe (vertical), when passing through ceilings, walls, roofs, enclosures, attic rafters or any combustible surfaces.

**DO NOT PACK AIR SPACES WITH INSULATION.**

Refer to the vent chart for maximum allowable vertical and horizontal installations.

When planning your installation determine if ceiling joists, roof rafters or other framing will obstruct the vent system. You may have to use 45° elbows to navigate around any obstacles. When passing through a flat ceiling install a Box/Wall thimble. Cut a 10" square hole and frame as shown in the diagram opposite.

Ensure all pipe sections are fully twist locked.

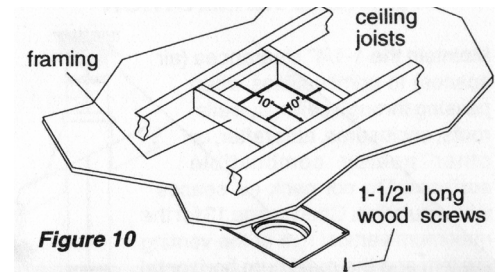

**NOTE: Always check your local codes before installing venting. Necessary clearances and requirements may vary from state to state(province to province).**



**INSTALLATION INSTRUCTIONS cont.**

**Through Roof Framing**

Maintain 10" opening relative to the pitch of the roof.

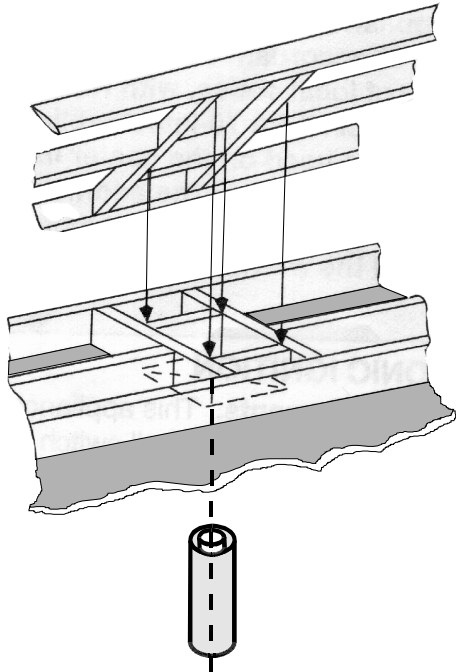

Use a suitable round or square support through the roof. Ensure adequate heat shield protection is provided.

**Termination Above Roof**

Consult local codes for minimum vent cap height above the roof, vent must be a minimum 2' from any wall.

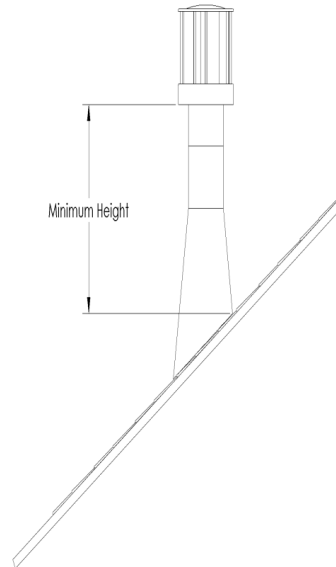

Install the flashing with upper portion slid under the roofing material and the lower portion over the roofing material.

**Note: Do not fasten down until the final adjustments to the vent have been made.**



## INSTALLATION INSTRUCTIONS cont.

### VENTING

This appliance will not function without being connected to a proper venting system. This unit can be used with Selkirk (Direct-Temp), American Metal, Security Chimneys or Simpson Duravent 4" x 6-5/8" venting. Read the manufacturer's installation instructions before installing the venting system.

### Typical Installation

- 24" (min) vertical vent pipe on top of the appliance,
- One 90° elbow, and up to 24" (max) horizontal run to the outside (with a 2' vertical rise).

### Other installations

- Up to 4 - 90° elbows, or equivalent, maximum.
- Minimum 2' (610mm) straight length between bends.
- The total vertical height up to 30' (9.14 m) maximum.
- Use vent restrictor over 20' vertical height .
- The total horizontal run up to 16' (4.88m) maximum.
- Note: 2' (0.6m) minimum of vertical height required.

**NOTE: Maximum vent lengths may be subject to local codes.**

### For best venting performance, here are some general venting rules:

1. Use only vent systems and components certified for use with this appliance.
2. Maintain a minimum of 1" (26 mm) clearance to combustibles from the outside surfaces of vertical vents and minimum of 1" (26 mm) sides and bottom, and 2" (51 mm) from top surfaces of horizontal vents. Always use a wall thimble when passing through combustible construction.
3. Observe all local code restrictions, if any, regarding the installation of this type of gas appliance.
4. Observe the vent height and length restrictions given in this manual.
5. Never slope horizontal vents downwards.
6. Maintain at least an upward slope of 1/4" (7 mm) for every 1 ft (305 mm) of horizontal vent.
7. Terminate the vent with a termination certified for use with this appliance.
8. Support horizontal vent every 3 ft (915 mm) to prevent it from sagging.

**INSTALLATION INSTRUCTIONS cont.**

VERTICAL VENTING

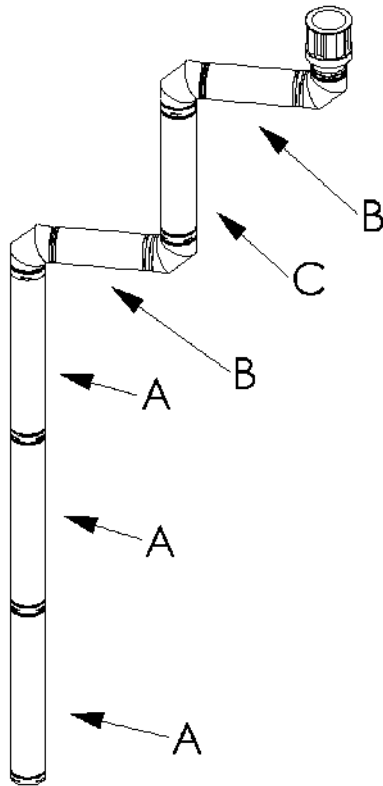

**Example 1**

**V Value** = 3A (12') + 1C (3') = 15'

**H Value** = 2B (4') = 4'

**V Value** = Total length of all vertical sections in feet.  
**H Value** = Total length of all horizontal sections in feet.

**Note:**

- for H & V values for 45° venting, see Chart IV “INSTALLATION INSTRUCTIONS cont.” on page 19
- elbows are not counted in H or V values
- vent chart starts from the top of the unit

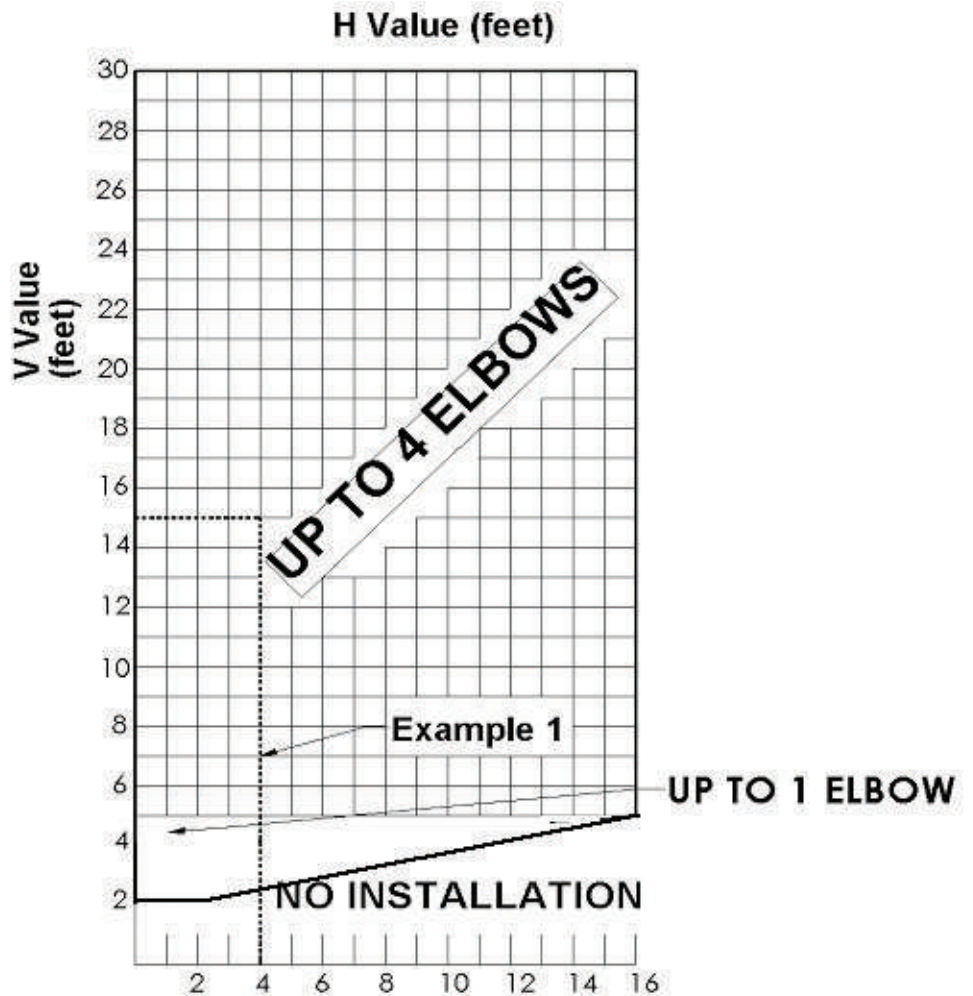

## INSTALLATION INSTRUCTIONS cont.

### Vent Restrictor (P/N 1851)

Due to the extra flow produced by certain venting configurations a vent restrictor must be placed in the vent to maintain performance. All top vent installations over 20' require the use of a 60% restrictor. The restrictor is installed in the exhaust of the appliance as shown in Figure's 4, 5, and 6.

If a restrictor is necessary it can be installed in the following order:

1. Turn off the appliance and allow it to cool to room temperature.
2. Carefully remove the logs and brick panels and place them in a safe location.
3. Remove the "FIREBOX BAFFLE" (4 screws). (Fig. 4)
4. Remove six screws from the "FIREBOX TOP". (Fig. 5)
5. Install the "VENT RESTRICTORS" in the air intake (6 screws). (Fig. 6)
6. Re-install the "FIREBOX BAFFLE". (Fig 4)
7. Install the logs.

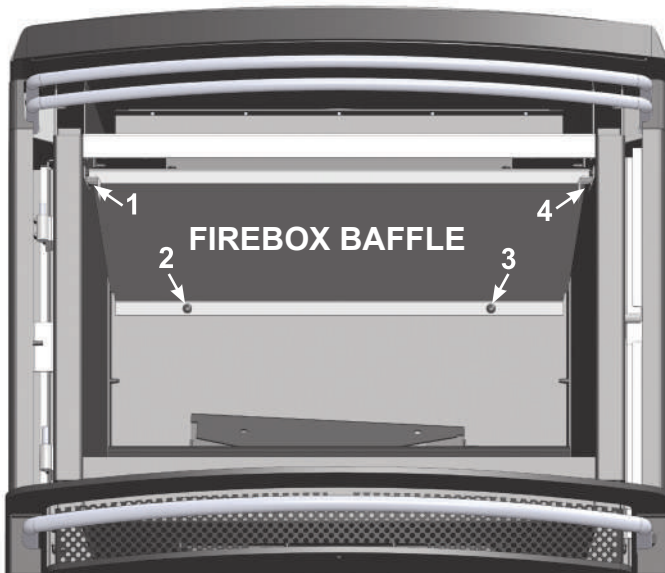

Fig. 4

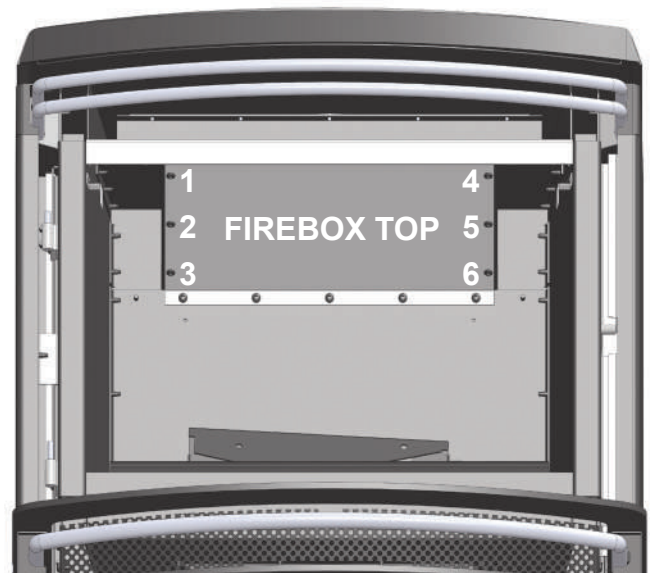

Fig. 5

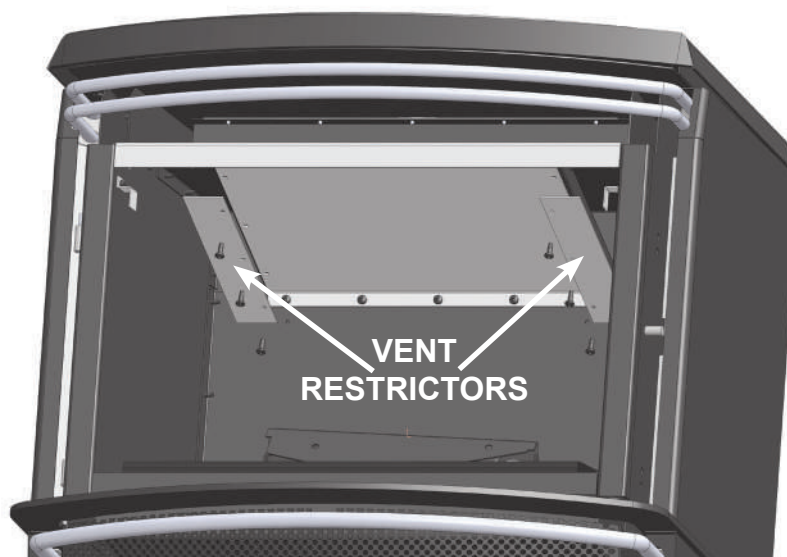
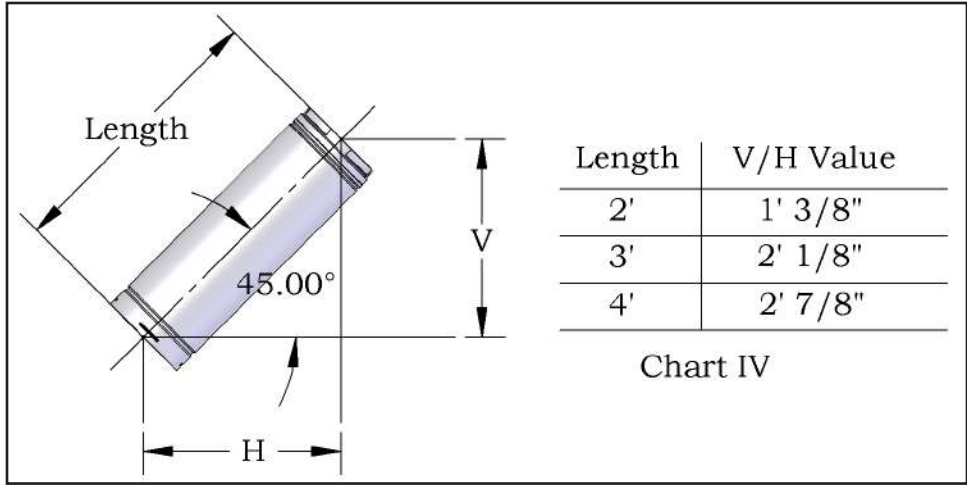

Fig. 6

**INSTALLATION INSTRUCTIONS cont.**

CHART IV



**Typical vent Installation**

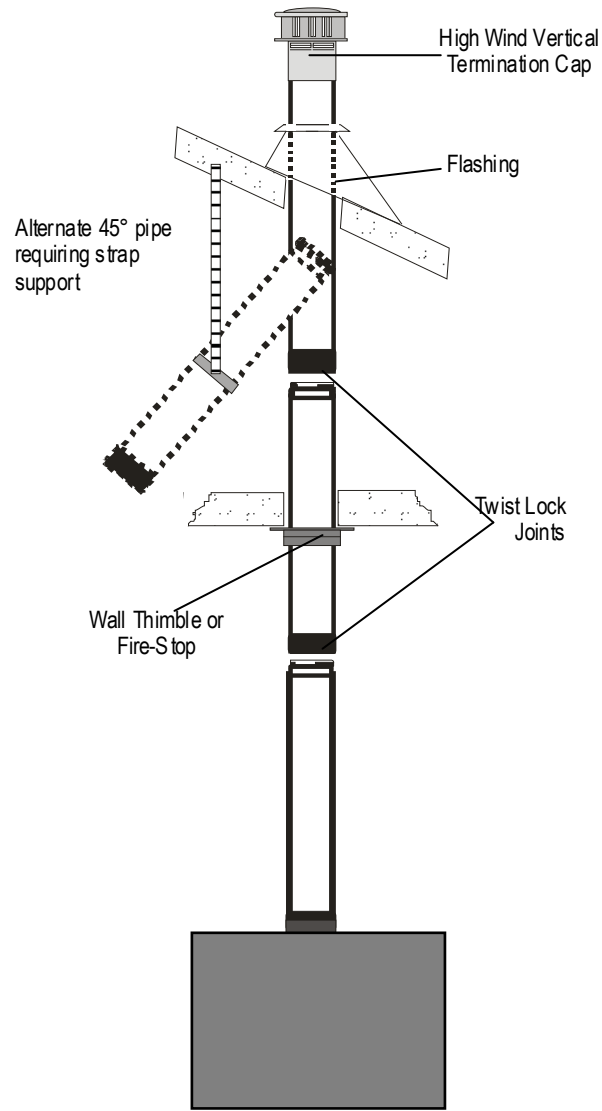

SIMPSON DURAVENT DIRECTVENT PRO / GS SYSTEM PARTS LIST		
Description	Part #	Old Part #
Horizontal Termination Kit - In Canada—Mandatory to add a wall thimble (46DVA-KHC.)	46DVA-KHA	971
Vertical Termination Kit	-	978
6" Pipe Length -Black	46DVA-06B	908B
6" Pipe Length -Galvanized	46DVA-06	908
8,5" Black Extension (3"-7")	46DVA-08AB	-
8,5" Galvanized Extension (3"-7")	46DVA-08A	-
9" Pipe Length-Black	46DVA-09B	907B
9" Pipe Length-Galvanized	46DVA-09	907
12" Pipe Length-Black	46DVA-12B	906B
12" Pipe Length-Galvanized	46DVA-12	906
16" Black Extension (3"-14.5")	46DVA-16AB	-
16" Galvanized Extension (3"-14.5")	46DVA-16A	-
24" Pipe Length-Black	46DVA-24B	904B
24" Pipe Length-Galvanized	46DVA-24	904
36" Pipe Length-Black	46DVA-36B	903B
36" Pipe Length-Galvanized	46DVA-36	903
48" Pipe Length-Black	46DVA-48B	902B
48" Pipe Length-Galvanized	46DVA-48	902
11"- 14 5/8" Adjustable Pipe Length-Black	-	911B
17"- 24" Adjustable Pipe Length-Black	-	917B
45° Elbow-Black	46DVA-E45B	945B, 945BG
45° Elbow-Galvanized	46DVA-E45	945, 945G
90° Elbow-Galvanized	46DVA-E90	990, 990G
90° Elbow-Black	46DVA-E90B	990B, 990BG
Vertical High Wind Termination Cap (must be used for all vertical terminations)	46 DVA-VCH	991
Horizontal. DV Termination with 1" return	-	984GL
Horizontal. Square Termination Cap	-	984
Horizontal. Square High Wind Termination Cap	46DVA-HC	985
Horizontal round termination cap	46DVA-HRCS	-
Sconce Termination Cap	46DVA-HSC	-
Wall Thimble Cover—Support Box	46DVA-DC	940
Cathedral Ceiling Support Box	46DVA-CS	941
Brass Trim fro Ceiling Support Box	-	3951
Firestop Spacer	46DVA-FS	963
Flashing 0/12-6/12	46DVA-F6	943
Flashing 7/12-12/12	46DVA-F12	943S
Storm Collar	46DVA-SC	953
Vinyl Siding Standoff	46DVA-VSS	950
Wall Strap	46DVA-WS	988
Wall Pen Heat Shield (Wall Thimble)	46DVA-WT	942

# TORINO II Freestanding 1606

SELKIRK PARTS LIST	PART NUMBER	DESCRIPTION
<b>4" x 6 5/8" LENGTHS</b>		
1604006	4DT- 6	DIRECT-TEMP 6" PIPE LENGTH
1604006B	4DT- 6B	DIRECT-TEMP 6" PIPE LENGTH BLACK
1604009	4DT- 9	DIRECT-TEMP 9" PIPE LENGTH
1604009B	4DT- 9B	DIRECT-TEMP 9" PIPE LENGTH BLACK
1604012	4DT-12	DIRECT-TEMP 12" PIPE LENGTH
1604012B	4DT-12B	DIRECT-TEMP 12" PIPE LENGTH BLACK
1604018	4DT-18	DIRECT-TEMP 18" PIPE LENGTH
1604018B	4DT-18B	DIRECT-TEMP 18" PIPE LENGTH BLACK
1604024	4DT-24	DIRECT-TEMP 24" PIPE LENGTH
1604024B	4DT-24B	DIRECT-TEMP 24" PIPE LENGTH BLACK
1604036	4DT-36	DIRECT-TEMP 36" PIPE LENGTH
1604036B	4DT-36B	DIRECT-TEMP 36" PIPE LENGTH BLACK
1604048	4DT-48	DIRECT-TEMP 48" PIPE LENGTH
1604048B	4DT-48B	DIRECT-TEMP 48" PIPE LENGTH BLACK
1604082	4DT-AJ12	DIRECT-TEMP 12" ADJ PIPE LENGTH
1604082B	4DT-AJ12B	DIRECT-TEMP 12" ADJ PIPE LENGTH BLACK
1604084	4DT-AJ14	DIRECT-TEMP TELESCOPE ADJ LENGTH
1604084B	4DT-AJ14B	DIRECT-TEMP TELESCOPE ADJ LEN BLACK
<b>4" x 6 5/8" FITTINGS</b>		
1604215	4DT-EL45	45 DEGREE ELBOW
1604215B	4DT-EL45B	45 DEGREE ELBOW BLACK
1604230	4DT-EL90S	90S DEGREE ELBOW
1604230B	4DT-EL90SB	90S DEGREE ELBOW BLACK
<b>4" x 6 5/8" ACCESSORIES</b>		
1604460B	4DT-WTB	WALL THIMBLE BLACK
1604500	4DT-FS	FIRESTOP SPACER
1604502	4DT-TP	TRIM PLATE BLACK
1604806	4DT-VS	VINYL SIDING STANDOFF
<b>4" x 6 5/8" SUPPORTS</b>		
1604400	4DT-CS	CEILING SUPPORT
1604424	4DT-CCS	CATHEDRAL SUPPORT BOX
1604430	4DT-WS/B	WALL SUPPORT/BAND
1604435	4DT-OS	OFFSET SUPPORT
<b>4" x 6 5/8" TERMINATIONS AND FLASHINGS</b>		
1604620	4DT-VKC	VERTICAL TERMINATION KIT
1604621	4DT-HKA	HORIZONTAL TERMINATION KIT "A"
1604622	4DT-HKB	HORIZONTAL TERMINATION KIT "B"
1604802	4DT-VC	HIGH WIND VERTICAL CAP
1604804	4DT-HC	HIGH WIND HORIZONTAL CAP
1604810	4DT-SC	STORM COLLAR
1604825	4DT-AF6	ADJ FLASH 0/12-06/12
1604830	4DT-AF12	ADJ FLASH 6/12-12/12

AMERICAN METAL PRODUCTS COMPONENTS LIST	
Description	Part #
7" Pipe Length	4D7
12" Pipe Length	4D12
2' Pipe Length	4D2
3' Pipe Length	4D3
4' Pipe Length	4D4
4" - 10" Adjustable Length	4D12A
45° Elbow	4D45L
90° Elbow	4D90L
Vertical Termination	4DVC
Horizontal Termination	4DHC
36" Snorkel	4D36S
Wall Thimble	4DWT
Wall Strap	4DWS
Firestop Support Plate	4DFSP
Faceplate, Ceiling Support / Wall Thimble	4DFPB
Roof Support	4DRSB
Storm Collar	4DSC
Standard Flashing	4DF
Steep Pitch Flashing	4DF12
Attic Insulation Shield	4DAIS12
SECURITY VENTING COMPONENTS LIST	
6" Pipe Length	SV4L6
12" Pipe Length	SV4L12
24" Pipe Length	SV4L24
36" Pipe Length	SV4L36
48" Pipe Length	SV4L48
6" Adjustable Length	SV4LA
12" Adjustable Length	SV4LA12
45° Elbow	SV4E45
90° Elbow	SV4E90
Wall Band	SV4BM
Insulated Attic Shield	SV4RSA
Wall Shield	SV4RSM
Firestop	SV4BF
Adjustable Roof Flashing 1/12 — 7/12	SV4FA
Horizontal Termination	SV4CHC
Vertical Termination	SV4CGV



**INTERMITTENT PILOT & VALVE**

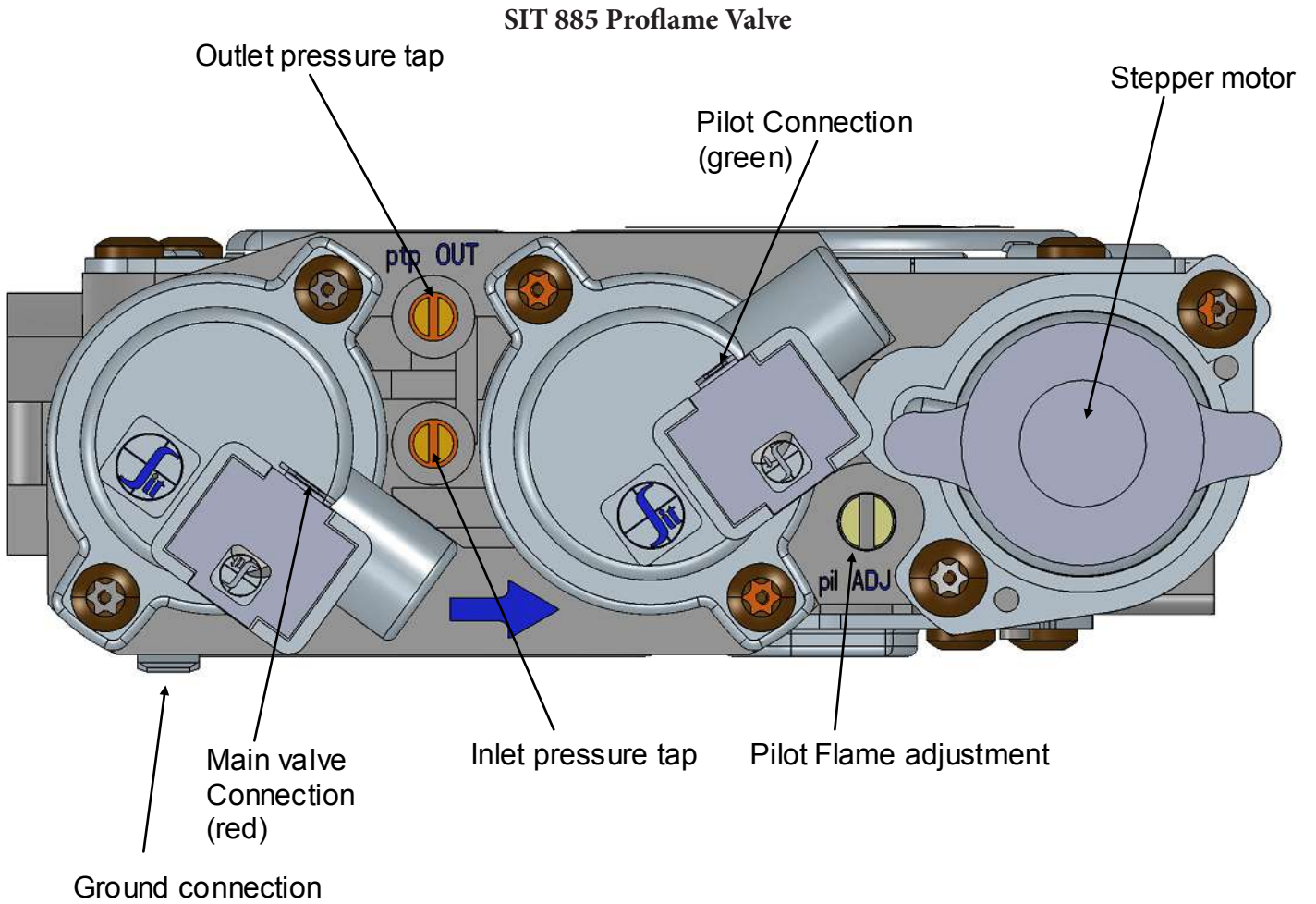

**INTERMITTENT PILOT & VALVE cont.**

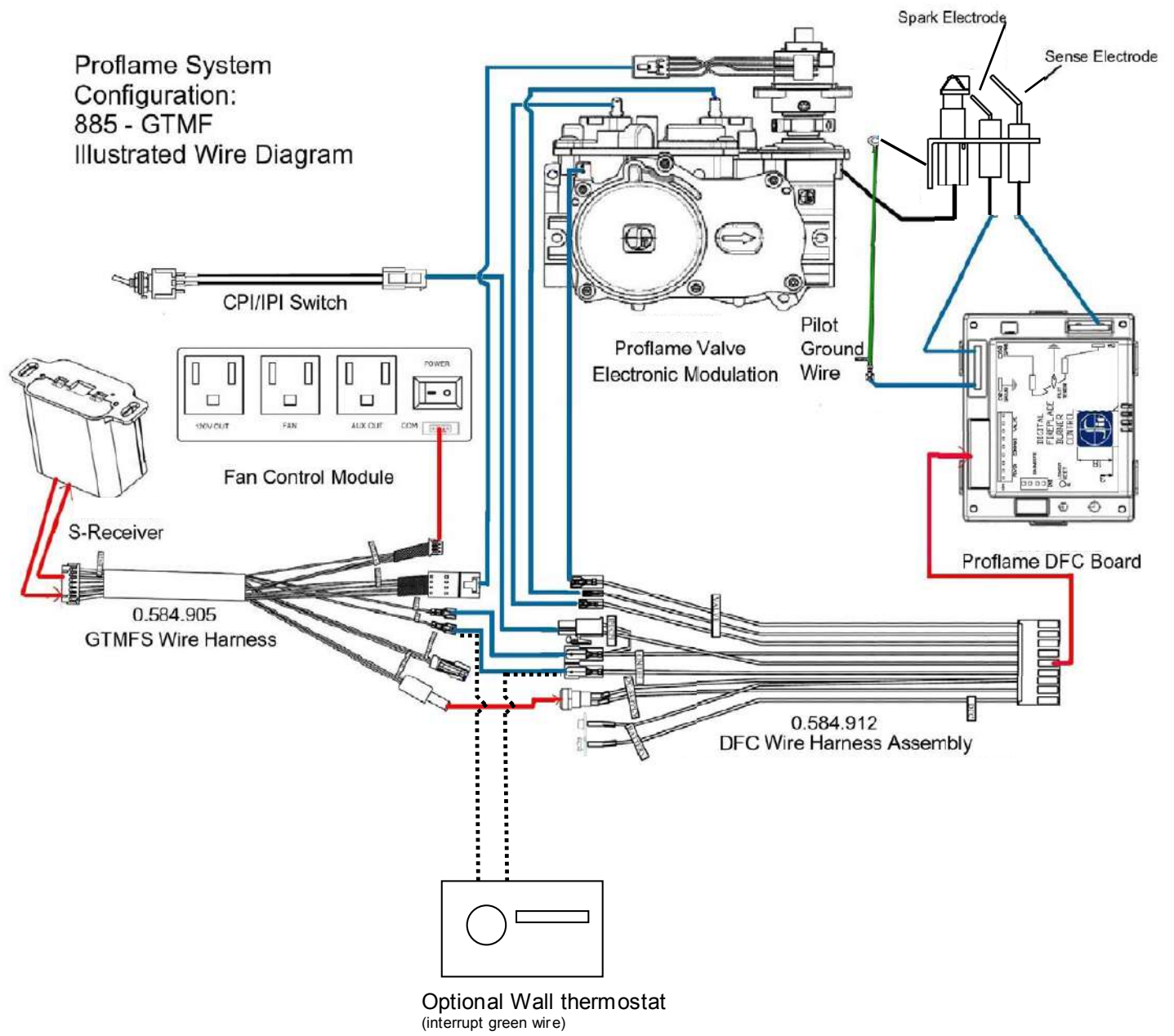

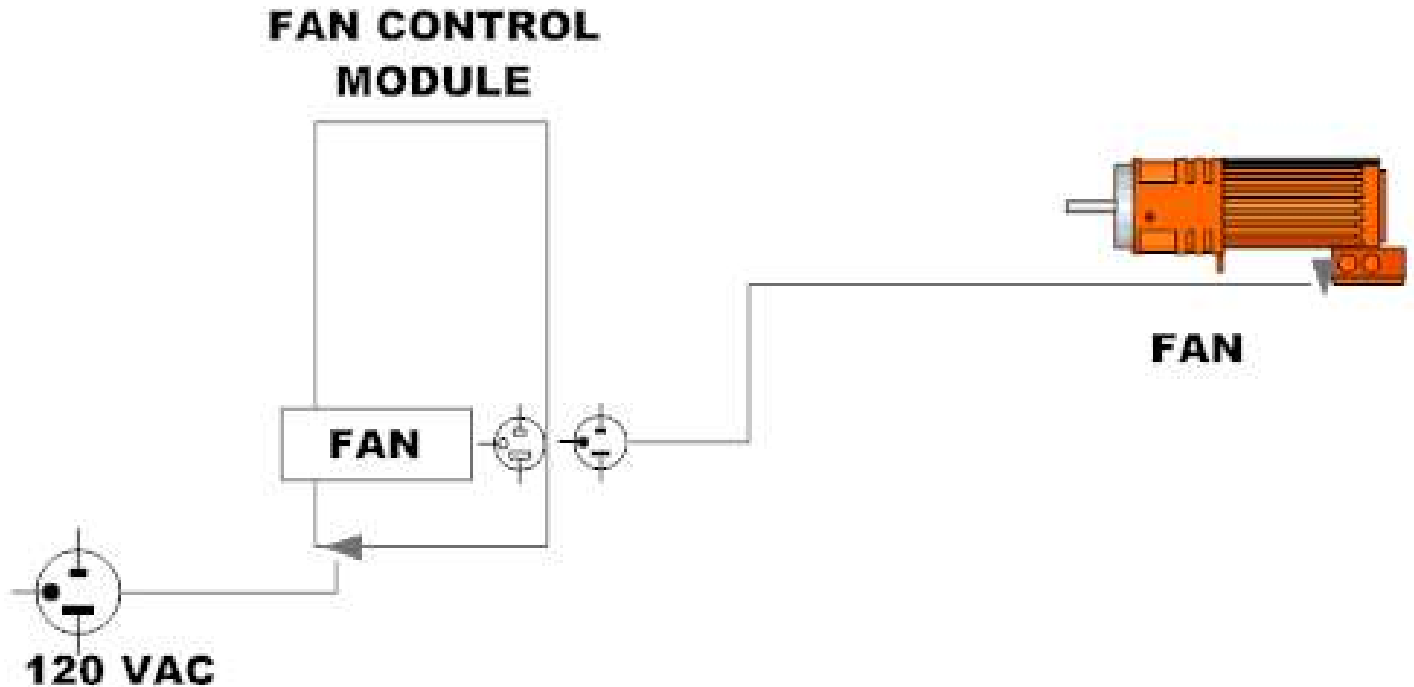
**WIRING DIAGRAM****WARNING****Electrical Grounding Instructions**

This appliance is equipped with a three prong (grounding) plug for your protection against shock hazard and should be plugged directly into a properly grounded three prong receptacle . Do not cut or remove the grounding prong from this plug.

The Appliance, when installed, must be electrically grounded in accordance with local codes or, in the absence of local codes, with the National Electrical Code, ANSI/NFPA 70, or the Canadian Electrical Code, CSA C22.1.

**CAUTION:**

Label all wires prior to disconnection when servicing controls. Wiring errors can cause improper and dangerous operation.

Verify proper operation after servicing.

## LIGHTING INSTRUCTIONS

### FOR YOUR SAFETY, READ BEFORE LIGHTING

**WARNING: If you do not follow these instructions exactly, a fire or explosion may result causing property damage, personal injury or loss of life.**

- A. This appliance is equipped with an ignition device which automatically lights the pilot. Do not try to light the pilot by hand.
- B. BEFORE LIGHTING smell all around the appliance area for gas. Be sure to smell next to the floor because some gas is heavier than air and will settle on the floor.  
**WHAT TO DO IF YOU SMELL GAS:**
  - Do not try to light any appliance.
  - Do not touch any electric switch; do not use any phone in your building.
  - Immediately call your gas supplier from a neighbor's phone. Follow the gas supplier's instructions.
  - If you cannot reach your gas supplier, call the fire department.
- C. Do not use this appliance if any part has been under water. Immediately call a qualified service technician to inspect the appliance and to replace any part of the control system and any gas control which has been under water.

## LIGHTING INSTRUCTIONS

1. **STOP!** Read the safety information above on this label.
2. Set the thermostat to the lowest setting.
3. Turn off all electric power to the appliance.
4. Do not attempt to light the pilot by hand.
5. Wait five (5) minutes to clear out any gas. Then smell for gas, including near the floor. If you smell gas, STOP! Follow "B" in the safety information above on this label. If you don't smell gas, go to the next step.
6. Turn on all electric power to the appliance.
7. You must now synchronize the remote with the Receiver/Battery Pack (for 1st time use) by pressing the PRG button on the Battery Pack (fig. 1 (Battery Pack is situated behind the Pedestal front or Louvers)) followed by pressing the "ON" button on the Remote.
8. Press the "ON" button on the Remote (fig. 2) or if not using the Remote turn the switch on the Battery Pack to the "ON" position (see figure1).
9. If the appliance will not operate, follow the instructions "To Turn Off Gas To Appliance" and call your service technician or gas supplier.

## TO TURN GAS OFF TO APPLIANCE

1. Press the "OFF" button on the remote or if not using the remote turn the switch on the battery pack to the "OFF" position. (See fig. 1)
2. Turn off all electric power to the appliance.

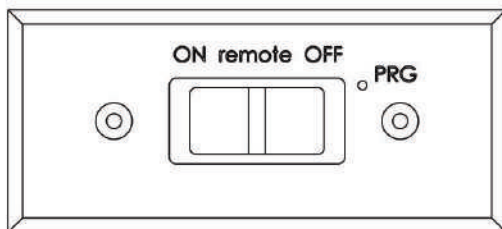

FIG 1: RECEIVER / BATTERY PACK

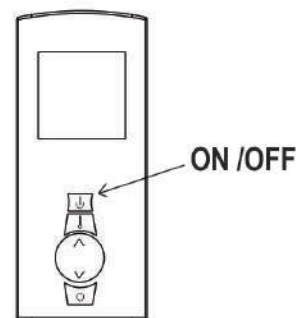

FIG 2: REMOTE CONTROL

#0361Se

## THERMOSTAT REMOTE CONTROL

### OPERATING PROCEDURE

#### Initializing the System for the first time

Install the 4 AA batteries into the receiver battery bay. Note the polarity of battery and insert into the battery bay as indicated on the Battery cover (+/-). Place the 3 position slider switch in the “Remote” position (Fig. 3). Using the end of a paper clip, or other similar object, insert the end of the paper clip into the hole marked “PRG” on the Receiver front cover (Fig. 3). The Receiver will “beep” three (3) times to indicate that it is ready to synchronize with a Transmitter. Install the 3 AAA type batteries in the Transmitter battery bay, located on the base of the Transmitter. With the batteries already installed in the Transmitter, push the On button. The Receiver will “beep” four times to indicate the Transmitter’s command is accepted and sets to the particular code of that Transmitter. The system is now initialized.

#### Temperature Indication Display

With the system in the “OFF” position, press the Thermostat Key and the Mode Key at the same time. Look at the LCD screen on the Transmitter to verify that a C or F is visible to the right of the Room Temperature display. (Fig. 6)

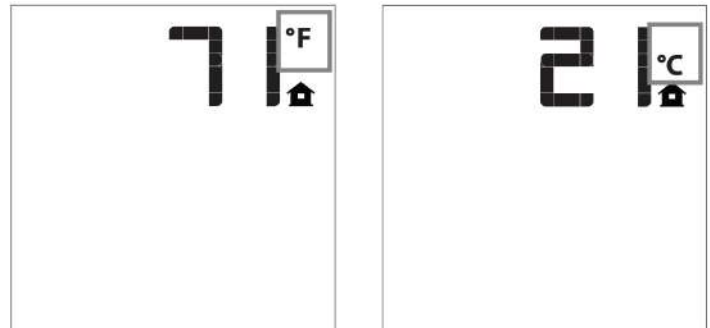

Fig. 6: Remote Control display in Fahrenheit and Celsius.

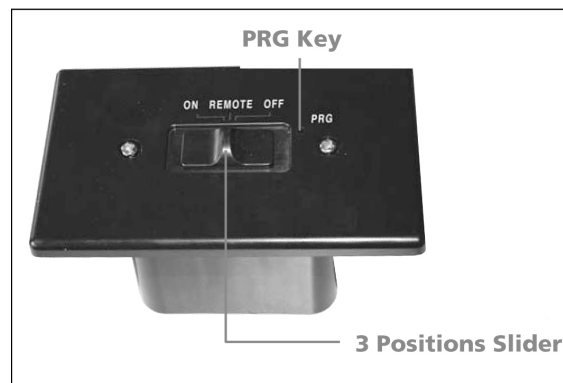

Fig. 3: Receiver body

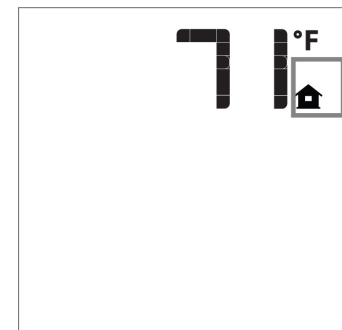

Fig. 7: Remote Control display.

#### Turn on the Appliance

Press the ON/OFF Key on the Transmitter. The Transmitter display will show all active Icons on the screen. At the same time the Receiver connects the thermopile to the gas valve millivolt coil and the appliance main burner turns on. A single “beep” from the Receiver will confirm reception of the command.

#### Turn off the Appliance

Press the ON/OFF Key on the Transmitter. The Transmitter LCD display will only show the room temperature and Icon (Fig. 7). At the same time the Receiver disconnects the thermopile from the gas valve millivolt coil and the appliance burner turns off. A single “beep” from the Receiver confirms reception of the command.



## THERMOSTAT REMOTE CONTROL cont.

### Remote Flame Control

The proflame GTMF has six (6) flame levels. With the system on, and the flame level at the maximum in the appliance, pressing the Down Arrow Key once will reduce the flame height by one step until the flame is turned off. The Up Arrow Key will increase the flame height each time it is pressed. If the Up Arrow Key is pressed while the system is on but the flame is off, the flame will come on in the high position. (Fig. 8 & 9) A single “beep” will confirm reception of the command.



Fig 8: Flame Off

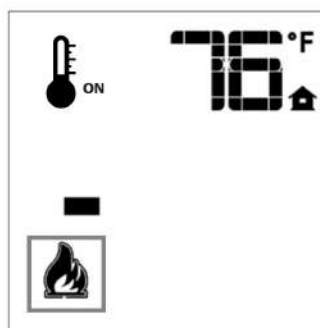

Flame Level 1

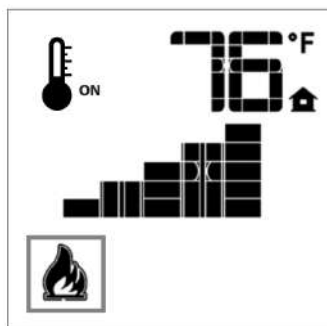
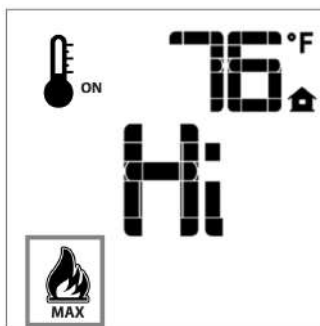

Fig 9: Flame Level 5



Flame Level Maximum

### Room Thermostat (Transmitter Operation)

The Remote Control can operate as a room thermostat. The thermostat can be set to a desired temperature to control the comfort level in a room.

To activate this function, press the Thermostat Key (Fig. 1). The LCD display on the Transmitter will change to show that the room thermostat is “ON” and the set temperature is now displayed (Fig. 10). To adjust the set temperature, press the Up or Down Arrow Keys until the desired set temperature is displayed on the LCD screen of the Transmitter.

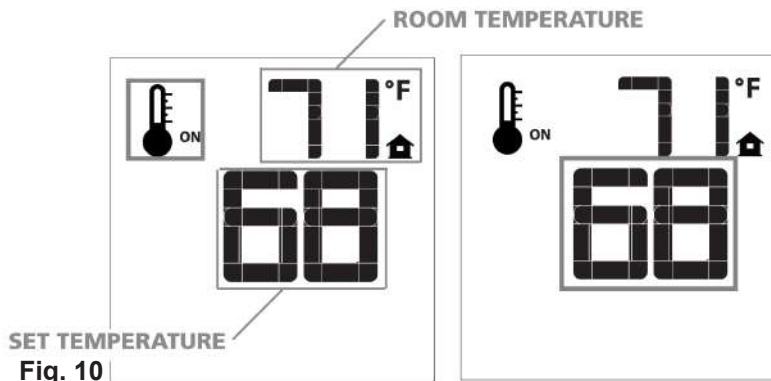

Fig. 10

Fig. 11

**THERMOSTAT REMOTE CONTROL cont.**

**Smart Thermostat (Transmitter Operation)**

The Smart Thermostat function adjusts the flame height in accordance to the difference between the set point temperature and the actual room temperatures. As the room temperature gets closer to the set point the Smart Function will modulate the flame down. To activate this function, press the Thermostat Key (Fig. 1) until the word “SMART” appears to the right of the temperature bulb graphic (Fig. 12). To adjust the set temperature, press the Up or Down arrow Keys until the desired set point temperature is displayed on the LCD screen of the Transmitter (Fig. 13).

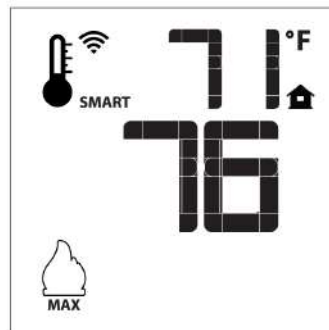

Fig. 12: Smart flame function

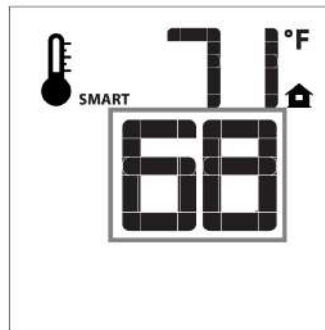

Fig. 13

**Fan Speed Control**

If the appliance is equipped with a hot air circulating fan, the speed of the fan can be controlled by the Proflame system. The fan speed can be adjusted through six (6) speeds. To activate this function use the Mode Key (Fig. 1) to index to the fan control Icon (Fig. 14). Use the Up Down Arrow Keys (Fig. 1) to turn on, off or adjust the fan speed (Fig. 15) A single ‘beep’ will confirm reception of the command.

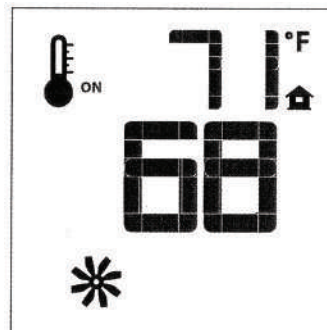

Fig. 14

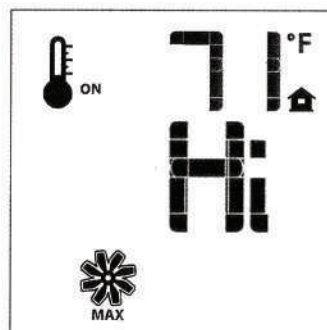

Fig. 15



## THERMOSTAT REMOTE CONTROL cont.

### Remote Actuated 120V Auxiliary Outlet

The auxiliary function controls the AUX power outlet on the Fan Control Module. To activate this function use the Mode Key (Fig. 1) to index to AUX Icon (Fig. 16 & 17). Pressing the Up Arrow Key will activate the outlet. Pressing the Down Arrow Key will turn the outlet off. A single 'beep' will confirm the reception of the command.



Fig. 16

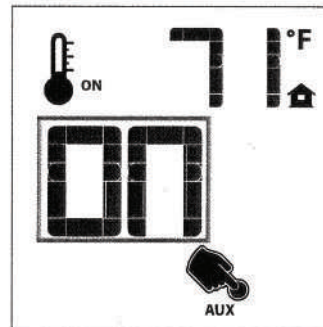

Fig. 17

### Key Lock

This function will lock the keys to avoid unsupervised operation. To activate this function, press the MODE and the UP Arrow Key at the same time (Fig. 18). To de-activate this function, press the MODE and the UP Arrow Key at the same time.

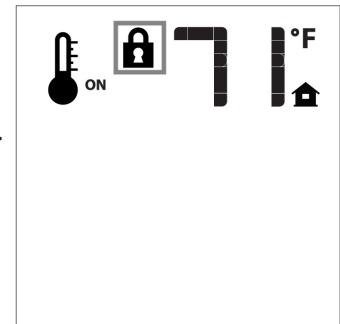

Fig. 18

### LOW BATTERY DETECTION

#### Transmitter

The life span of the remote control batteries depends on various factors: quality of the batteries used, the number of ignitions of the appliance, the number of changes to the room thermostat set point, etc. When the Transmitter batteries are low, a Battery Icon will appear on the LCD display of the Transmitter (Fig. 19) before all battery power is lost. When the batteries are replaced this Icon will disappear.

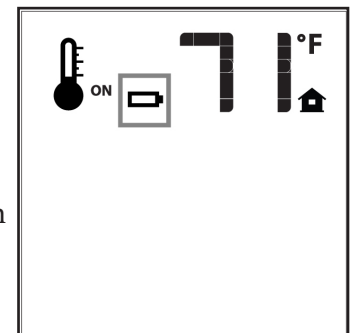

Fig. 19

#### Receiver

The life span of the Receiver batteries depends on various factors: quality of the batteries used, the number of ignitions of the appliance, the number of changes to the room thermostat set point, etc. When the Receiver batteries are low, No "beep" will be emitted from the Receiver when it receives an On/Off command from the Transmitter. This is an alert for a low battery condition for the Receiver. When the batteries are replaced the "beep" will be emitted from the Receiver when the ON/OFF Key is pressed (See Initialization of The System).

**THERMOSTAT REMOTE CONTROL cont.**

**MANUAL BYPASS OF THE REMOTE SYSTEM**

If the batteries of the Receiver or Transmitter are low or depleted, the appliance can be turned on manually by sliding the three position slider switch on the Receiver to the ON position. This will bypass the remote control feature of the system and the appliance main burner will come on if the gas valve is in the “On” position.

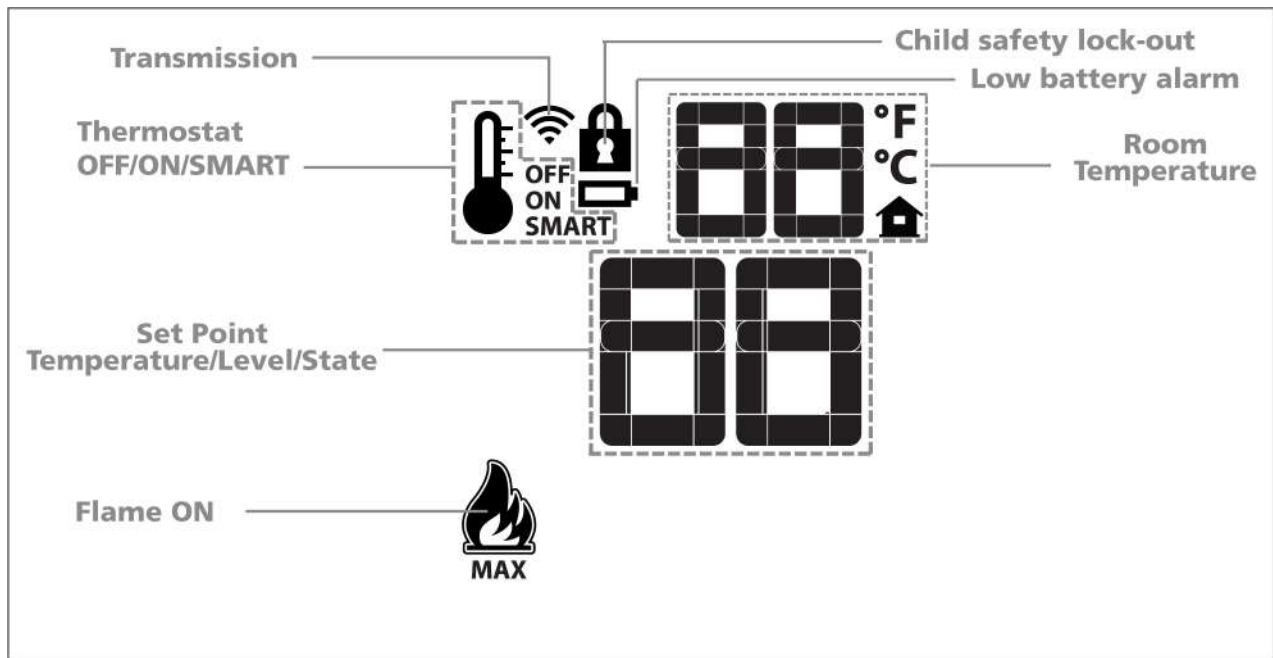

**CONTINUOUS PILOT**

The pilot on this unit will light automatically when turning the unit on.

If a standing pilot is preferred (especially in cold weather), the pilot can be run continuously by switching the continuous pilot switch to the ON position. The switch is located behind the pedestal cover, above the Receiver / Battery pack.

## MAINTENANCE

### CAUTION:

Do not conduct maintenance on the appliance while it is operating or while it is still hot. Make sure switch on the Battery pack / Receiver is in OFF position. Turning the electric supply off will not prevent unexpected ignition !!

### CLEANING THE APPLIANCE

The exterior surfaces and glass may be cleaned with a soft, non-abrasive cloth and water or a suitable, mild, non-abrasive cleaner.

#### Regularly,

- Clean and remove any lint accumulations or debris from the grills and in any combustion and convection air passage ways.
- Keep the appliance area free from combustible materials, such as paper, wood, clothing, gasoline and flammable solids, liquids and vapors.
- Check for unusual noise, odor and operation of the appliance.
- Check the vent terminal for any damage, or obstruction by plants or debris accumulation.
- Visually check the height and color of the burner and pilot flames.

#### Once a Year have a qualified service technician,

- Completely inspect the appliance and the venting system.
- Clean and remove any lint accumulations or debris in the firebox, on the burners, on the pilot, at the primary air opening, on the convection air blower and in any combustion and convection air passage ways, see "FAN REMOVAL AND INSTALLATION" on page 39
- Check the safety system of the gas valve.

### WARNING :

All parts removed or disturbed must be properly replaced after maintenance. Service and repair must be conducted by a qualified service person. If these instructions are not followed, a fire or explosion may result, causing property damage, personal injury or loss of life.

VERIFY PROPER OPERATION AFTER SERVICING

### PLATING

- The plating requires little maintenance and needs only to be cleaned with a soft damp cloth. Do not use any abrasive cleaning materials.
- Avoid fingerprints on gold. Wipe off fingerprints before firing.

### DOOR

- Check the gasket to see that it is still forming a seal. Replace gasket if there is any sign of wear.

### VIEWING GLASS REPLACEMENT:

- This appliance is supplied with high temperature 5mm high temperature ceramic glass that will easily withstand the heat your unit was designed to produce. In the event the glass breaks, contact your dealer or BLAZE KING to arrange for your glass to be replaced / repaired.

**MAINTENANCE cont.****IMPORTANT - GLASS CLEANING - WHITE MINERAL DEPOSITS**

One of the by products of the combustion process in a gas appliance, is a mineral which can show up as a white film on the ceramic glass of the viewing door. The composition of the deposit varies widely from various locations and also from time to time in the same location. You may have the problem for a time and then not see it for many months when it will reappear in your area. It seems this is associated with the varying sulfur content of the gas. We have discussed this problem with ceramic glass manufacturers and they cannot give us a definitive answer to this problem. Dealers have tried various cleaning products with varying results. The following recommendations will not guarantee results in your particular case. Ensure the stove is completely cooled before any glass service work is attempted. Make sure switch on the Battery pack / Receiver is in OFF position.

Turning the electric supply off will not prevent unexpected ignition !!

Clean the glass regularly as soon as you notice the buildup (white film). If the film is left for a long period of time build up will bake on. It is then much harder, if not impossible, to remove.

1. NEVER use an abrasive cleaner on the ceramic glass. Any abrasion of the surface has the immediate effect of lessening the strength of the glass. An emulsion type cleaner is recommended.
2. Use a soft damp cloth to apply the cleaner. Dry the glass with a soft, dry, preferably cotton cloth. Most paper towels and synthetic materials are abrasive to ceramic glass and should be avoided.
3. Our dealers have had good results from the products listed below. We can not however guarantee the results of these products.
  - a) BRASSO
  - b) POLISH PLUS by KEL KEM
  - c) COOK TOP CLEAN CREME by ELCO
  - d) WHITE OFF by RUTLAND

**NOTE: This is a problem beyond Blaze King's control  
and is not covered under warranty.**

**NOTICE: COLD WEATHER OPERATION**

When using any gas appliance (LPG or NAT Gas) water is a by product of the combustion process. Under normal conditions this moisture is expelled through the vent into the atmosphere and does not cause any harm. In extreme cold weather the vapor may condense and freeze on any exposed surface it comes into contact with. This can cause a problem by restricting or blocking the vent, particularly with direct vent wall terminations as the exhaust is only a few inches away from the outside wall surface. What happens to the moisture after it leaves the vent cannot be controlled by the manufacturer. To extend the vent further out from the wall can sometimes but not always be an advantage. Extending the vent out from the wall may present other design problems such as ice falling from the eaves above. It is the homeowners responsibility to ensure that there is not an excessive build-up of ice on the termination.

**CAUTION:**

WHEN OPERATING YOUR APPLIANCE DURING COLD WEATHER YOU MUST FREQUENTLY CHECK THE EXHAUST CAP FOR EXCESSIVE ICE BUILD UP. If the appliance begins to operate abnormally—Poor flame pattern, shutting down, etc..., this could be an indication of ice build up.

## SERVICING

### SERVICING UNDER WARRANTY

Before servicing, read the terms and conditions of the Blaze King warranty at the back of this manual. Contact the Blaze King authorized dealer which you purchased the appliance from and provide him with details of the problem and the installation information which the installer filled out at the back of the manual.

#### WARNING:

Servicing of this appliance must be conducted by a qualified service technician. Improper servicing, adjustment or alteration of this appliance may cause property damage, personal injury or loss of life. All servicing should be conducted with the appliance cold.

### ADJUSTING PRIMARY AIR

1. Open both side doors, then open the front door.
2. Loosen the Robertson lever lock screw holding the aeration lever.
3. Pulling the lever increases aeration, pushing the lever decrease aeration.
4. Tighten the lever lock screw once there is satisfactory adjustment.

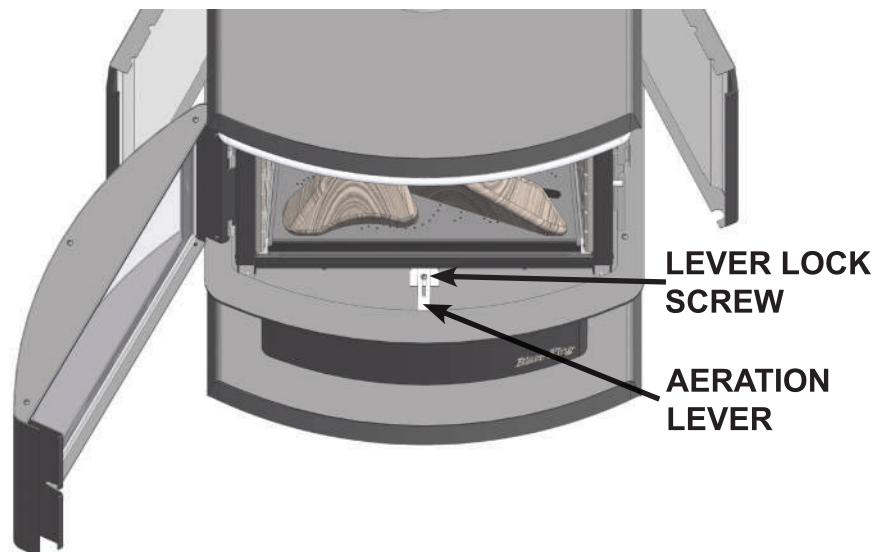

### CHANGING MAIN BURNER ORIFICE

1. Remove the glass door, logs and firebox liner panels.
2. Remove the burner.
3. Use a 3/8" wrench to unscrew the orifice.
4. Change the orifice. Do not over tighten.
5. Replace all parts in reverse order and properly set the primary air shutters according to the specifications
6. Check for leaks.

### CHECKING INLET AND OUTLET GAS PRESSURE

1. The pressure test taps are located on the valve.
2. The taps are located in the front.
3. Loosen the set screw inside the tap with a 1/8" wide flat screw driver.
4. Connect a 1/4" rubber tube to the tap and a pressure gauge.
5. Be sure to tighten the set screw inside the tap after you are finish taking pressure readings.

**FUEL CONVERSION**

**WARNING:**

This conversion kit shall be installed by a qualified service agency in accordance with the manufacturer's instructions and all applicable codes and requirements of the authority having jurisdiction. If the information in these instructions is not followed exactly, a fire, explosion or production of carbon monoxide may result causing property damage, personal injury or loss of life. The qualified service agency is responsible for the proper installation of this kit. The installation is not proper and complete until the operation of the converted appliance is checked as specified in the manufacturer's instructions supplied with the kit.

**CONVERSION KIT CONTENTS**

This conversion kit contains the following parts:

1. Z0712 (LPG)> # 53 and LPG Stepper motor kit.
2. Z0714 (NG)> # 38 and NG Stepper motor kit.
3. Conversion Kit labels.

**To convert from NG to LPG or reverse, follow the next steps:**

1. Replace orifices, see "BURNER TRAY REMOVAL AND INSTALLATION" on page 37 for Burner tray removal & installation.
2. Replace stepper motor (see next page).
3. Convert pilot fuel (see instructions below).

**How to convert Pilot fuel:**

1. Use a 7/16" wrench to loosen the pilot hood.
2. Push the little tab in and the little tab with hole should pop out. The hole stamp tab (LP) out is used for Propane. The stamped tab (NA) out is for Natural Gas.
3. Re-tighten the pilot hood.

Fill out the fuel conversion label on the appliance (inside side doors)

See "ASSEMBLY INSTRUCTIONS cont." on page 10 for proper pilot and burner flame pictorials.

All valves have been pre-set and certified for installation at elevations from 0 – 4500 feet (1 – 1372m) above sea level.

**HIGH ELEVATIONS**

When installing this unit at higher elevations, it is necessary to decrease the input rating by replacing the existing burner orifice with a smaller size for installations over 4500 feet (1370 m). The appliances input should be reduced 4% for each additional 1000 feet (305 m) above sea level. For the USA, de-rate the unit from sea level according to the gas installation code.

Altitude	NG	LPG
0 – 4,500 ft (0 – 1372 m)	36	52
4,500 – 6,500 ft (1372 – 1981 m)	38	53



## FUEL CONVERSION cont.

### STEPPER MOTOR PRESSURE REGULATOR CONVERSION KIT INSTALLATION OR REPLACEMENT INSTRUCTIONS.

Verify that the following items are present in the package.

- Pressure regulator assembly (E)
- Two (2) screws (F)
- Identification label (G)
- Installation instructions (this document).

- 1** Shut off the gas supply to the valve and shut down the electric supply.
- 2** See Fig. 1. Using a Torx T20, or slotted screwdriver, remove and discard the two (2) pressure regulator mounting screws (A), pressure regulator tower (B), and the spring and diaphragm assembly (C), (If applicable).
- 3** Ensure the rubber gasket (D), which is prefitted as part of assembly (E), is properly positioned, see Fig. 2, otherwise fit the gasket as shown Fig. 2.
- 4** Install the new STEPPER MOTOR pressure regulator assembly, as shown in Fig. 3 and Fig. 4. Use the supplied screws (F), M4 x 0.7 threaded, length of thread  $L=(16\text{ mm} + 0 - 0.5\text{ mm})$ , steel material, resistance class 8.8 (see Fig. 5).
- 5** Manually thread the two conversion kit mounting screws into the valve body. Use a standard screwdriver or T20 Torx bit and tighten to the screws with a fixing torque of  $25\text{lb-in} \pm 5\%$ .  
IN THE EVENT THAT THE THREADS OF THE VALVE ARE STRIPPED OR DAMAGED, **REPLACE THE VALVE.**
- 6** Install the enclosed identification label (G) to the valve body where it can be easily seen.
- 7** Make STEPPER MOTOR and valve electrical connections, apply gas to system and relight appliance according to manufacturers instructions.
- 8** With the main burner "ON", test the new pressure regulator assembly for leaks using a soap solution.
- 9** Relight the main burner and verify proper burner ignition and operation.

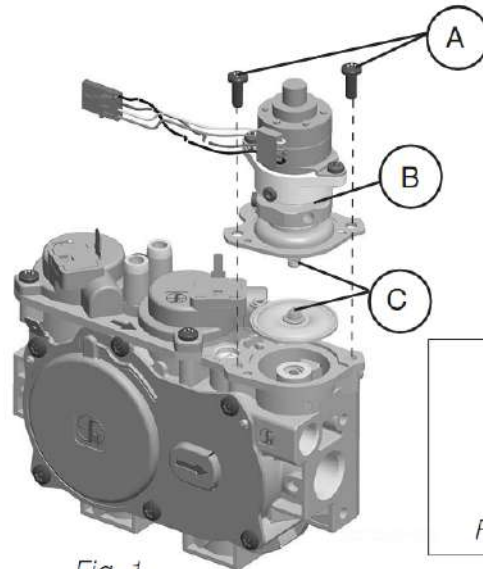

Fig. 1

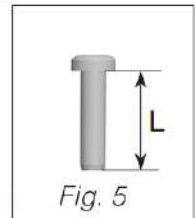

Fig. 5

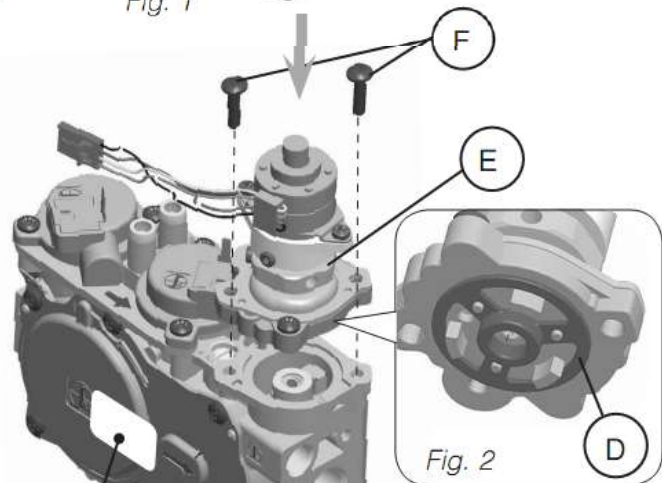

Fig. 2



Fig. 3

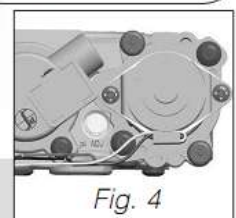

Fig. 4

**WARNING!**  
Installation should be carried out in a clean environment.

**WARNING!**  
This modulating conversion kit must **ONLY** be applied as part of a conversion kit supplied by the **APPLIANCE MANUFACTURER** for the specific appliance, and type of gas, being converted.

**WARNING!**  
Correct operation of the system cannot be guaranteed if the conversion kit or valve has been dropped or has sustained a strong impact.

**INSTALLER NOTICE.** These instructions must be left with appliance.

## BURNER TRAY REMOVAL AND INSTALLATION

To remove the burner tray from the firebox, follow these steps:

1. Disconnect the gas and electricity to the appliance.
2. Open door.
3. Take out logs and brick panels.
4. Unscrew the two screws holding the burner in place (see fig 10b)
5. Lift out burner at front and take out of firebox

### INSTALL BURNER TRAY

When placing the burner tray back into the firebox, make sure the mixing tube plenum (see fig 20a) slides over the orifice. Screw burner tray into firebox with two screws (see fig 20b), backup quarter turn on one of the screws (for expansion in material).

When properly installed you should NOT be able to lift up the Burner tray at the back, the burner should just move slightly (the distance between orifice and inside plenum tube) .

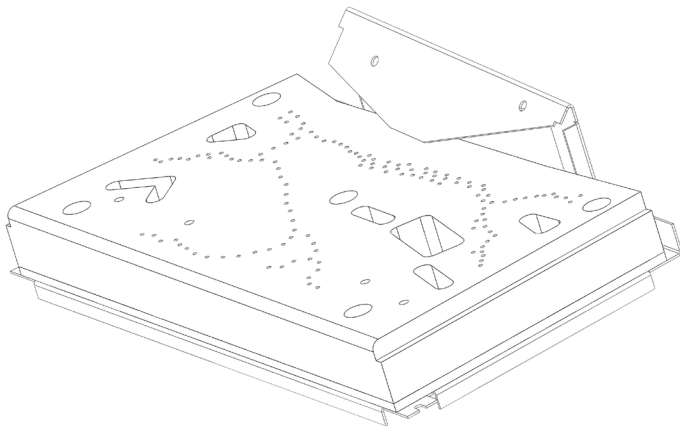
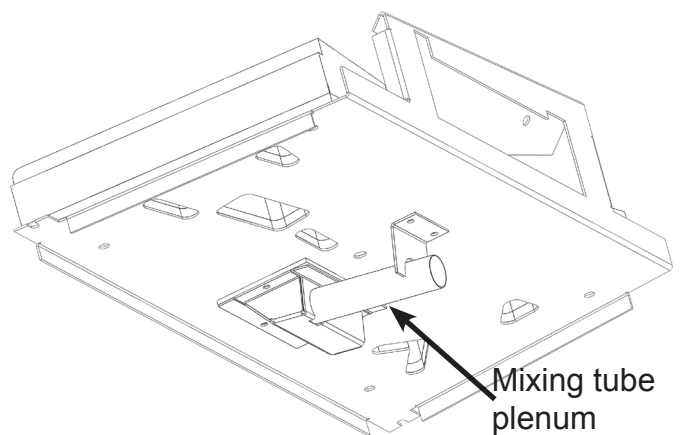

Fig. 20a



Burner Tray (bottom view)

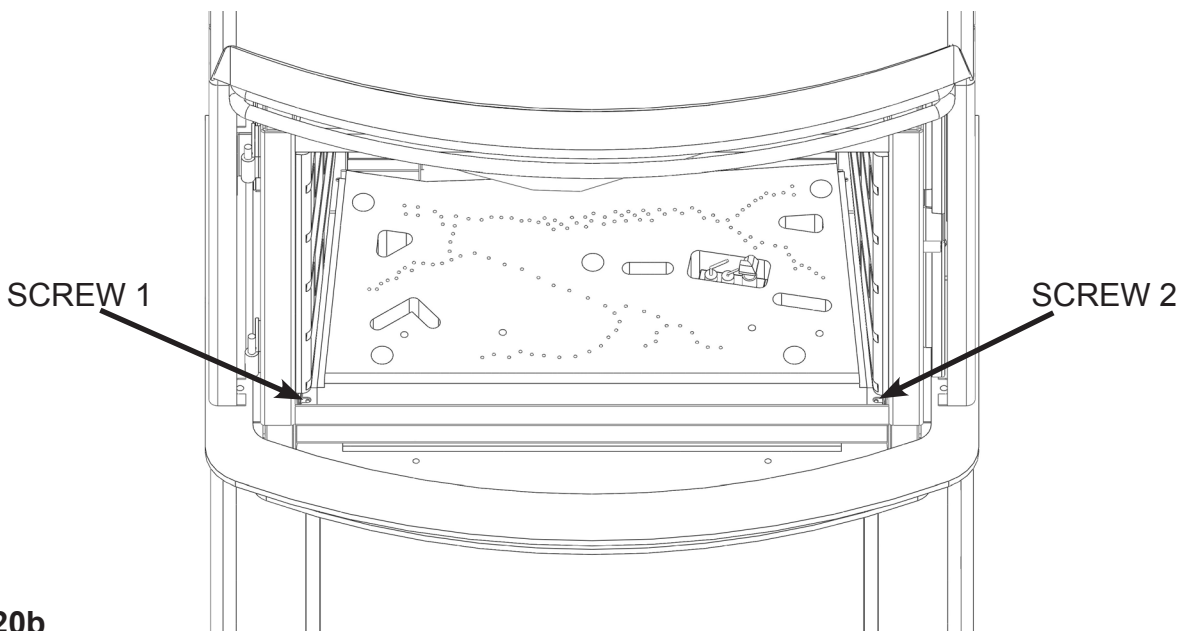

Fig. 20b

## VALVE REMOVAL AND INSTALLATION

### TO BE DONE BY QUALIFIED PERSONNEL ONLY

1. Disconnect the gas and electricity to the appliance.
2. Remove pedestal front cover and rear cover (4 screws) including fan (fig. 20c).
3. Undo the gas lines (one in, two out and pilot).
4. Disconnect all electrical connections to valve including ground wire
5. Valve is attached to valve bracket with 4 screws, 2 at the back (see fig. 20d) and two at the side, loosen all of them.
6. Installation is the reverse order of the previous steps.

**NOTE: WHEN INSTALLING NEW VALVE, CHECK IF ANY UNUSED PORTS ARE PLUGGED.  
CHECK OUTLET PRESSURE (3.5" W.C.) AND CHECK FOR LEAKS**

See "INTERMITTENT PILOT & VALVE" on page 23 for detailed gas valve image.



Fig. 20c

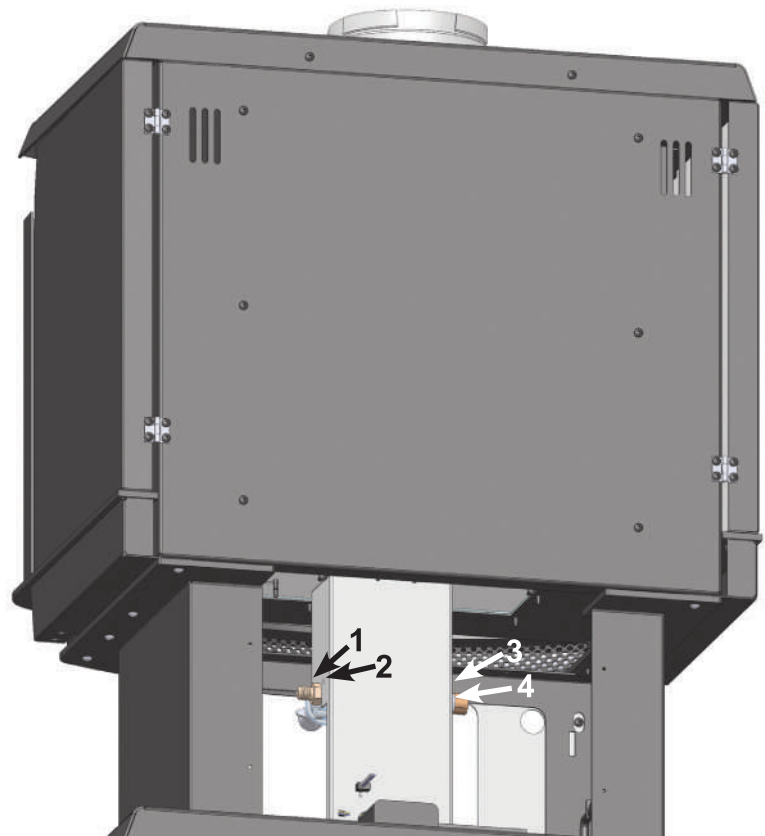

Fig. 20d

## FAN REMOVAL AND INSTALLATION

To remove the fan, for maintenance or replacement, is easily accomplished by the following steps:

1. Turn off gas.
2. Disconnect electrical power to the appliance.
3. Remove the 4 screws holding the rear pedestal fan bracket to the appliance. (Fig. 21)
4. Disconnect all wires, be sure to label wires prior to disconnecting to ensure they are replaced in the correct location.
5. Remove the 4 screws holding the fan to the rear pedestal fan bracket. (Fig. 21)
6. Installation is the reverse order of the previous steps.

### WARNING:

#### Electrical Grounding Instructions

This appliance is equipped with a three prong (grounding) plug for your protection against shock hazard and should be plugged directly into a properly grounded three prong receptacle. Do not cut or remove the grounding prong from this plug.

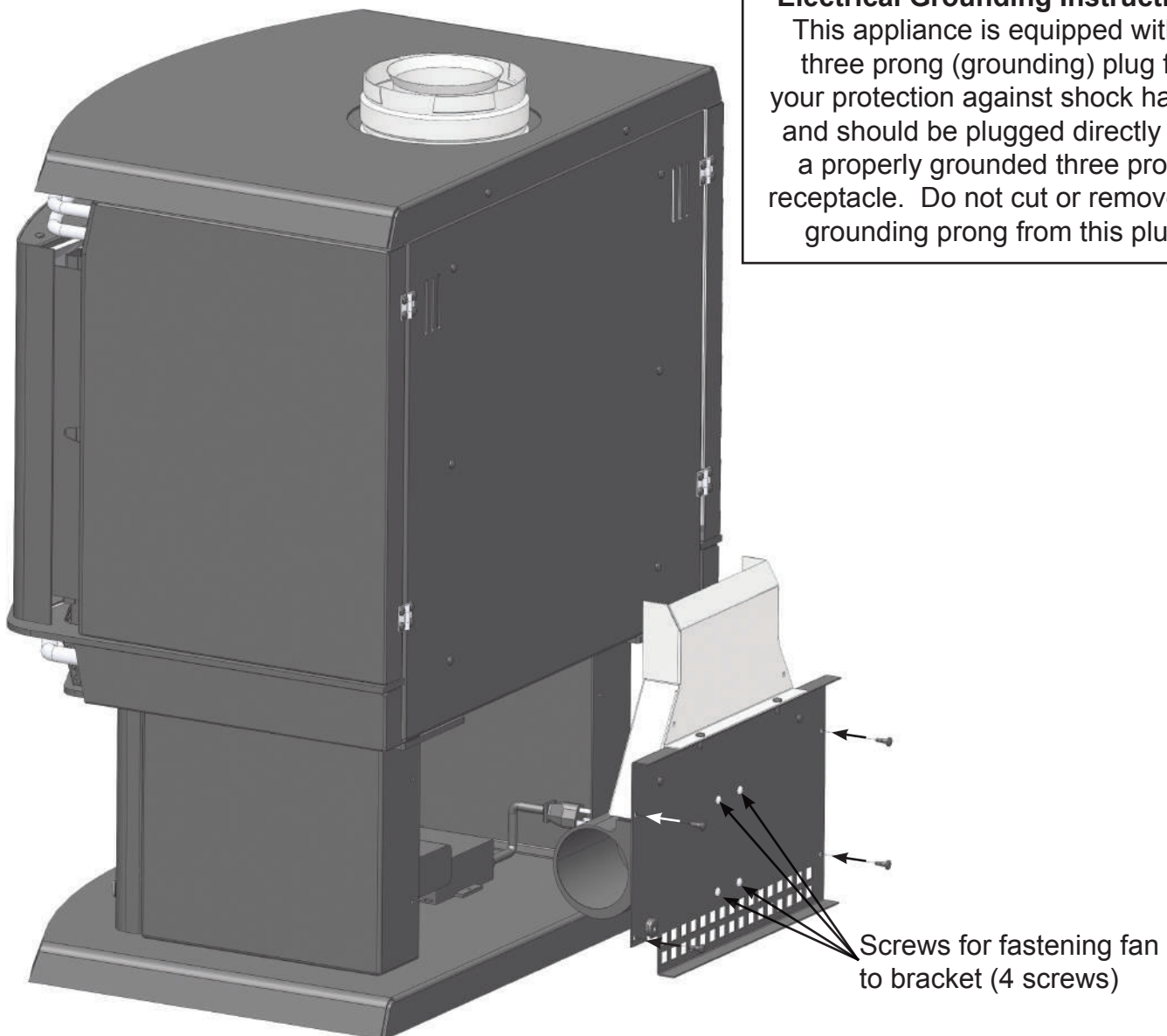
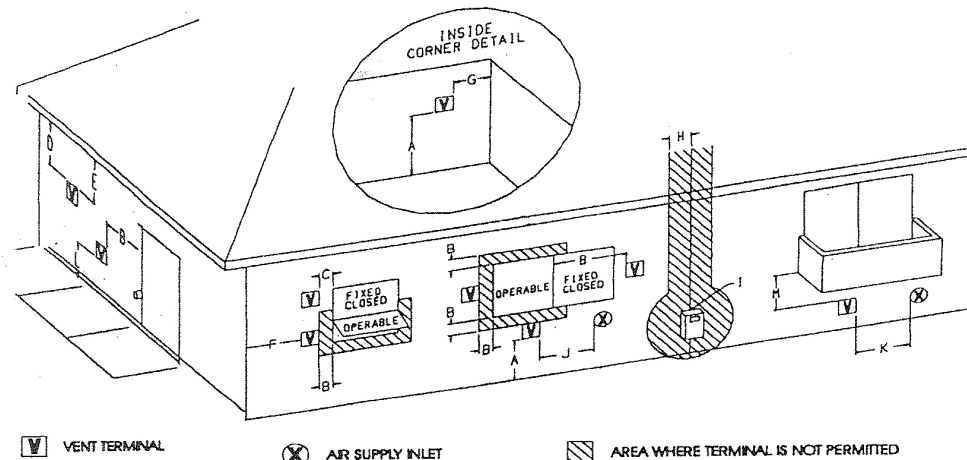

Fig. 21



## ALLOWABLE TERMINATION LOCATIONS



A= Clearance above grade, veranda porch, deck or balcony	*(min. 12"/30 cm)	*(min. 12"/30 cm)
B= Clearance to window or door that may be opened	*(min. 12"/30 cm)	*(min. 12"/30 cm)
C= Clearance to permanently closed window	*(min. 12"/30 cm)	*(min. 12"/30 cm)
D= Vertical clearance to ventilated soffit located above the terminal from the centerline of the terminal	*min. 25-1/2" (65 cm) check with local code	*min. 25-1/2" (65 cm) check with local code
E= Clearance to unventilated soffit from the centerline of the terminal.	*min. 25-1/2" (65 cm)	*min. 25-1/2" (65 cm)
F= Clearance to outside corner from the centerline of the terminal.	*min. 10"/25cm	*min. 10"/25cm
G= Clearance to inside corner the centerline of the terminal.	*min. 16"/40cm	*min. 16"/40cm
H= Clearance to each side of centerline extended above meter/regulator assembly	3' (91cm) within a height 15' (4.5m) above the meter/regulator assembly	*
I= Clearance to service regulator vent outlet	3' (91cm)	*
J= Clearance to no mechanical air supply inlet to building or the combustion air inlet to any other appliance	12" (30cm)	9" (23cm)
K= Clearance to a mechanical air supply inlet	6' (1.83 m)	3' (91 cm) above if within 10' (3 m) horizontally
L= Clearance above paved sidewalk or paved driveway located on public property	7' (2.13 m)†	*
M = Clearance under veranda, porch, deck or balcony	12" (30 cm)‡	*

<sup>1</sup> In accordance with the current CSA B149.1, *Natural Gas and Propane Installation Code*

<sup>2</sup> In accordance with the current ANSI Z223.1/NFPA 54, *National Fuel Gas Code*

† A vent shall not terminate directly above a sidewalk or paved driveway that is located between two single family dwellings and serves both dwellings.

‡ Permitted only if veranda, porch, deck or balcony is fully open on a minimum of two sides beneath the floor.

\* For clearances not specified in *ANSI Z223.1/NFPA 54* or *CSA B149.1*, one of the following shall be indicated:

a) A minimum clearance value determined by testing in accordance with section 2.23.7, or ;

b) A reference to the following footnote: "Clearance in accordance with local installation codes and the requirements of the gas

**TROUBLESHOOTING**

Please check to make sure the instructions are followed exactly before attempting trouble shooting of the appliance.

**WARNING:**  
**Troubleshooting and servicing of gas and electrical devices of the appliance should only be conducted by a qualified service technician.**

SYMPTOM	ACTION
The pilot will not stay lit.	<ol style="list-style-type: none"> <li>1. Confirm that the Spark electrode and sense electrode wires are properly connected to the DFC board, see "INTERMITTENT PILOT &amp; VALVE" on page 23.</li> <li>2. Confirm that the Pilot burner is properly grounded to the DFC board and stove chassis.</li> <li>3. Check the power source or the battery pack connections and condition of batteries.</li> </ol>
If the main burner does not come ON when the manual switch or remote control is turned ON.	<ol style="list-style-type: none"> <li>1. Confirm that the pilot sparks and lights.</li> <li>2. Confirm that the Spark electrode and sense electrode wires are properly connected to the DFC board, see "INTERMITTENT PILOT &amp; VALVE" on page 23</li> <li>3. If using the remote control check the condition of the batteries.</li> <li>4. Check if there is gas supply to the appliance.</li> </ol>
Pilot will not light.	<ol style="list-style-type: none"> <li>1. When lighting the appliance for the first time after installation or after servicing, there is air in the gas line. It takes a while for all the air to purge out of the pilot before gas can reach the pilot and ignite. Remove the glass door and try lighting the pilot many times to purge the air.</li> <li>2. Check to make sure the gas supply to the appliance is turned on and there is adequate gas supply pressure to the appliance.</li> <li>3. Check for sparks between the spark electrode and the pilot head when the unit is turned on. If there are no sparks,                         <ol style="list-style-type: none"> <li>a) Check for broken or poor connection from the sparker to the electrode.</li> <li>b) Check for the spark shorting or arcing at other locations.</li> <li>c) Check for defective sparker.</li> <li>d) Check for defective spark electrode.</li> <li>e) Check the power source or the battery pack connections and condition of batteries.</li> </ol> </li> </ol>
The main burner shuts off when the appliance is warm.	<ol style="list-style-type: none"> <li>1. This may be the normal operation of a wall thermostat installed to appliances.</li> <li>2. Check for good pilot flames on the flame sensor see Fig.3 "ASSEMBLY INSTRUCTIONS cont." on page 10.</li> <li>3. Check for proper functioning of venting system (including termination for blockage).</li> <li>4. Check wire connections. Expansion from heat affects a loose connection.</li> <li>5. Check for adequate grounding from the Module, see "INTERMITTENT PILOT &amp; VALVE cont." on page 24</li> </ol>



## TROUBLESHOOTING cont.

SYMPTOM	ACTION
Sooty deposits on the glass door.	<ol style="list-style-type: none"> <li>1. If the flame is yellow and lazy, check for lint etc. around primary air shutter. Increase primary air by opening the primary air shutter if necessary, see "SERVICING" on page 34.</li> <li>2. Check for proper placement of the logs and branches. Ensure logs and burner are clean, see "ASSEMBLY INSTRUCTIONS cont." on page 10.</li> <li>3. Check for proper venting and blockage of the vent termination.</li> <li>4. Check manifold pressure and clock input rating for over-firing.</li> </ol>
Sharp blue flames with flames lifting off the burner at the ends.	<ol style="list-style-type: none"> <li>1. Too much primary air. Reduce primary air by closing the primary air shutter. During cold temperatures, some flame lifting may occur during start-up, see "SERVICING" on page 34.</li> </ol>
Convection blower does not turn on.	<ol style="list-style-type: none"> <li>1. The convection fan is thermostatically controlled. It will only turn on when the appliance is warmed-up. This may take up to 5 minutes with the appliance on high.</li> <li>2. Check for 120VAC electrical supply to the appliance. (Is the cord plugged in?)</li> <li>3. Check if speed controller is not in OFF position</li> <li>4. Check electrical connections.</li> <li>5. Check for defective convection blower speed controller.</li> <li>6. Check for defective convection blower.</li> </ol>

<b>REPLACEMENT PARTS</b>
--------------------------

No Expl. View	Item #	Description	QTY	Unit
	OM1606	OWNERS MANUAL, TORINO II Freestanding 1606	1	EA
	Z0712	CONVERSION KIT-NATURAL GAS to PROPANE 0-4,500ft	1	EA
	Z0713	CONVERSION KIT-NATURAL GAS to PROPANE 4,500-6,500ft	1	EA
	Z0714	CONVERSION KIT-PROPANE to NATURAL GAS 0-4,500ft	1	EA
	Z0715	CONVERSION KIT-PROPANE to NATURAL GAS 4,500-6,500ft	1	EA
1	6065	BRICK PANEL CLIP	2	EA
2	1736	FIREBOX BAFFLE	1	EA
3	1618	DOOR	1	EA
4	1666	CERAMIC DOOR GLASS	1	EA
5	0254C-6ft	DOUBLE BULB TADPOLE	1	EA
6	1613	BRICK PANEL SET (3 PIECES)	1	EA
7	SIT001	VALVE with STEPPER MOTOR	1	EA
8	SIT004	PROFLAME RECEIVER with FAN TIMING	1	EA
9	SIT003	IGNITION CONTROL	1	EA
10	SIT002	FAN CONTROL	1	EA
11	1619	BURNER TRAY ASSEMBLY	1	EA
12	Z1634	SATIN TRIM SET	1	EA
13	1851	VENT RESTRICTOR	2	EA
14	SIT005	TRANSMITTER	1	EA
15	0823	TORINO II LOG SET 1606/1607	1	EA
16	0712A	PSE PILOT	1	EA
	SIT006	IPI HARNESS with SWITCH	1	EA
	SIT007	REMOTE CONTROL HARNESS	1	EA
	0719F	FAN BLOWER	1	EA

**REPLACEMENT PARTS cont.**

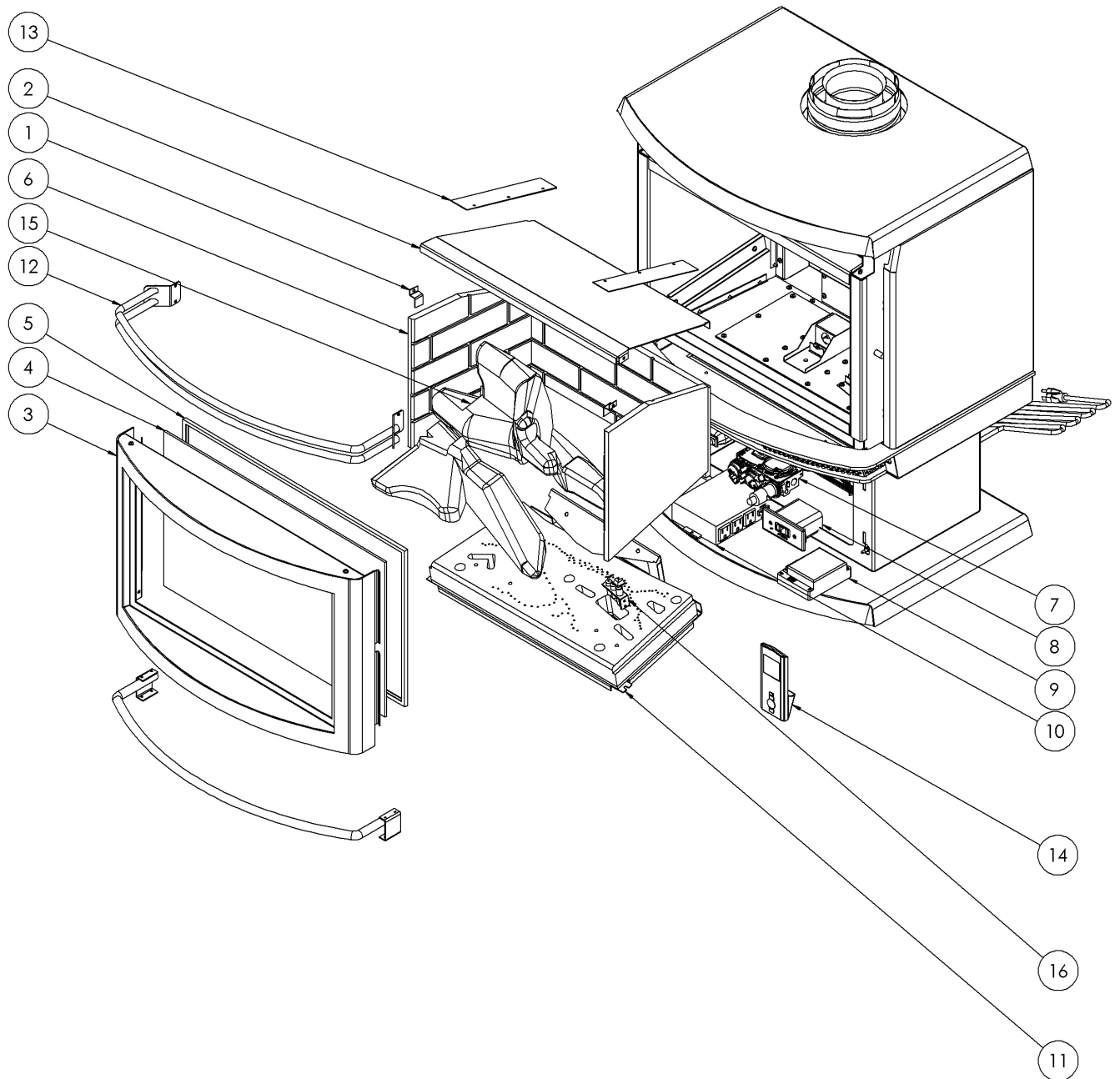

**WARRANTY**

**BLAZE KING GAS LIMITED WARRANTY**

Blaze King and its respective brands extend the following warranty for gas appliances purchased from an authorized Blaze King dealer and installed in the United States of America or Canada. Warranty starts with date of purchase by the original owner (End User) except as noted for replacement parts.

Warranty Period		Components Covered	
Parts	Labor	Gas	
1 Year		X	All parts, materials and surface finishes (flaking and peeling). Except as covered by Conditions Exclusion, and Limitations listed
2 Years		X	Igniters, Thermocouple, Thermopile Molded Refractory Panels, Log sets, Fan assembly, Ignition components, Gas valve, Burner components, Thermostat
5 Years	2 Years	X	Firebox & Heat Exchanger
10 Years	2 Years	X	All Exterior Steel Cabinets (excluding paint finishes) Glass (thermal breakage only)
1 Year		X	Other Replacement Parts
See Conditions, Exclusions, and Limitations			

## WARRANTY cont.

### Blaze King Gas Limited 10 Year Warranty

Blaze King is the manufacturer of the Blaze King line of heating products. At Blaze King, our commitment to the highest level of quality and customer service is the most important thing we do. Each Blaze King stove is built on a tradition of using only the finest materials and is backed by our limited lifetime warranty to the original purchaser. With Blaze King, you're not just buying a fireplace or stove, you're buying a company with years of unequalled performance and quality.

#### Limited 10 Year Warranty:

Under this warranty, Blaze King covers the fireplace or stove, exterior body, pedestals, legs and glass (thermal breakage only) against defects in materials and workmanship, for part repair or replacement for (10) years from original purchase date and limited labor for the first two (2) years to the original purchaser. This warranty does not cover exterior finishes. Please see the exclusions and limitation section below as certain restrictions and exclusions apply to this warranty.

#### Limited 5 Year Warranty:

Under this warranty, Blaze King covers the fireplace or stove firebox and heat exchanger against defects in materials and workmanship, for part repair or replacement for the first five (5) years and limited labor for the first two (2) years to the original purchaser. This Warranty covers: Heat Exchanger, Steel Firebox Panels and any steel components not covered under the ten (10) year Warranty excluding burner components and gas components. Please see the exclusions and limitation section below as certain restrictions and exclusions apply to this warranty.

#### Limited Two (2) Year Warranty:

Under this warranty, Blaze King covers: Gas Assembly, Burner components (ceramic and steel), Log sets, Blower and control, Temperature Sensors, thermocouple, thermopile, electronic ignition components and wire harness against defects in materials and workmanship, for part repair or replacement for the first two (2) years and limited labor for the first two (2) years to the original purchaser. Please see the exclusions and limitation section below as certain restrictions and exclusions apply to this warranty.

#### Limited One (1) Year Warranty:

Under this warranty, Blaze King covers all exterior surface finishes against defects in materials and workmanship, for part repair or replacement and limited labor for the first (1) year to the original purchaser. Please see the exclusions and limitations section below as certain restrictions and exclusions apply to this warranty.

#### How the Warranty Works (Includes Conditions, Exclusions and Limitations)

1. All warranties by the manufacturer are set herein and no claim shall be made against the manufacturer on any oral warranty or representation. All claims under this Limited Warranty must be made in writing by your dealer.
2. Any stove or part thereof that is repaired or replaced during the Limited Warranty period will be warranted under the terms of the Limited Warranty for a period not exceeding the remaining term of the original Limited Warranty or six (6) months, whichever is longer.
3. For any part or parts of this stove, which in our judgment show evidence of defects, Blaze King reserves the option to repair or to replace the defective product through an accredited distributor or agent, provided the defective part is returned to the distributor or agent, transportation prepaid, if requested.
4. If you discover a problem that you think may be covered by the Limited Warranty, you MUST REPORT it to your Blaze King dealer WITHIN 30 DAYS from the date the problem was first detected, giving them proof of purchase and the date of purchase. The dealer will investigate the problem and work with Blaze King to determine whether the problem:
  - a) Is covered by the Limited Warranty or
  - b) Can be fixed in your home or does the product need to be returned to Blaze King for repair.
5. If Blaze King determines that the stove needs to be returned to Blaze King for repair, the customer has the responsibility and the expense of removing it from their home and shipping it to Blaze King. If the problem is covered by the Warranty, Blaze King will repair or replace the item at their discretion and the customer will be responsible for return shipping and re-installation in their home.
6. If the problem is not covered by the Limited Warranty, the customer will be responsible for all repair costs, as well as all storage, shipping and the cost of removing and re-installing the stove.

**WARRANTY cont.**

If you are not satisfied with the service provided by the Blaze King dealer, write to Blaze King at the address listed on the last page of the Owner's Manual. Include a copy of the original purchase invoice and a description of the problem.

**Exclusions and Limitations:**

1. This Warranty does not cover tarnish, discoloration or wear on the plated surfaces. Painted finishes will change colour after initial firing and will continue to change through the lifetime of the stove. This is normal occurrence for all high temperature coatings.
2. This Warranty excludes wear and tear or breakage caused by cleaning, moving or service on log set and panels.
3. Blaze King strongly recommends that installation be done by a certified installer. Failure to comply may adversely affect coverage under this warranty. This Limited Warranty covers defects in materials and workmanship only if the product has been installed in accordance with local building and fire codes; in their absence, refer to the owner's manual. If the product is damaged or broken as a result of any alteration, wilful abuse, mishandling, accident, neglect, or misuse of the product, the Limited Warranty does not apply.
4. The stove must be operated and maintained at all times in accordance with the instructions in the Owner's Manual. If the unit shows signs of neglect or misuse, it is not covered under the terms of this Warranty policy. Performance problems due to operator error will not be covered by the Limited Warranty policy.
5. Some minor expansion, contraction, or movement of certain parts and resulting noise, is normal and not a defect and, therefore, is not covered under this Limited Warranty.
6. Misuse includes over-firing. Over-firing this appliance can cause serious damage and will nullify the Limited Warranty.
7. The Limited Warranty will cover glass thermal breakage only and will not cover misuse of the stove glass, including but not limited to glass that is struck, has surface contaminates or has had harsh or abrasive cleaners used on it.
8. This warranty does not cover products made or provided by other manufacturers and used in conjunction with the operation of this stove without prior authorization from Blaze King. The use of such products may nullify the Limited Warranty on this stove. If unsure as to the extent of this Limited Warranty, contact your authorized Blaze King dealer before installation.
9. Blaze King will not be responsible for inadequate performance caused by environmental conditions.
10. The Limited Warranty does not cover installation and operational related problems such as use of downdrafts or spillage caused by environmental conditions. Environmental conditions include but are not limited to nearby trees, buildings, roof tops, wind, hills, mountains, inadequate venting or ventilation, excessive offsets, negative air pressures or other influences caused by mechanical systems such as furnaces, fans, clothes dryers etc.
11. The Limited Warranty is void if:
  - a) The stove has been operated in atmospheres contaminated by chlorine, fluorine or other damaging chemicals.
  - b) The stove is subject to submersion in water or prolonged periods of dampness or condensation.
  - c) Any damage to the unit, combustion chamber or other components due to water, or weather damage which is the result of, but not limited to, improper chimney/venting installation.
  - d) Salt air in coastal areas or high humidity can be corrosive to the finish; these environmental can cause rusting. Damage caused by salt air or high humidity is not covered by the Limited Warranty.
12. Exclusions to the Limited Warranty include: injury, loss of use, damage, failure to function due to accident, negligence, misuse, improper installation, alteration or adjustment of the manufacturer's settings of components, lack of proper and regular maintenance, alteration, or act of God.
13. The Limited Warranty does not cover damage caused to the fireplace or stove while in transit. If this occurs, do not operate the stove and contact your courier and/or dealer.
14. Limited Warranty does not extend to or include firebox paint, door or glass gaskets with damage caused by normal wear and tear, or exterior paint discoloration or chipping, worn gaskets, etc.
15. The Limited Warranty does not include damage to the unit caused by abuse, improper installation, or modification of the unit.
16. Damage to plated surfaces caused by fingerprints, scratches, melted items, or other external scores and residues left on the plated surfaces from the use of abrasive cleaners or polishes is not covered in this warranty.
17. The Limited Warranty does not cover tarnish, discoloration or wear on the plated surfaces.
18. The paint on the brick liner may peel. It is not a flaw and is not covered under warranty, due to extreme conditions in the firebox.



**WARRANTY cont.**

19. Blaze King is free of liability for any damages caused by the fireplace or stove, as well as inconvenience expenses and materials. The Limited Warranty does not cover incidental or consequential damages.
20. The Limited Warranty does not cover any loss or damage incurred by the use or removal of any component or apparatus to or from the Blaze King fireplace or stove without the express written permission of Blaze King and bearing a Blaze King label of approval.
21. Any statement or representation of Blaze King Products and their performance contained in Blaze King advertising, packaging literature, or printed material is not part of the Limited Warranty.
22. The Limited Warranty is automatically voided if the fireplace or stove's serial number has been removed or altered in any way. If the stove is used for commercial purposes, it is excluded from the Limited Warranty.
23. No dealer, distributor, or similar person has the authority to represent or warrant Blaze King Products beyond the terms contained within the Limited Warranty. Blaze King assumes no liability for such warranties or representations.
24. Blaze King will not cover the cost of the removal or re-installation of the stove, hearth, facing, mantels, venting or other components.
25. Labor to replace or repair items under this Limited Warranty will be covered per our warranty service fee reimbursement schedule. Labor rates are set per component and as such total labor costs may not be covered.
26. If a defect or problem is determined by Blaze King to be non warrantable, Blaze King will not be liable for travel costs for service work. In the event of in-home repair work, the customer will pay any in-home travel fees or service charges required by the Authorized Dealer.
27. At no time will Blaze King be liable for any consequential damages which exceed the purchase price of the unit. Blaze King has no obligation to enhance or modify any stove once manufactured (example: as a stove model evolves, field modifications or upgrades will not be performed).
28. This Limited Warranty is applicable only to the original purchaser and it is non-transferable.
29. This warranty only covers Blaze King Products that are purchased through an authorized Blaze King dealer.
30. If for any reason any section of the Limited Warranty is declared invalid, the balance of the warranty remains in effect and all other clauses shall remain in effect.
31. The Limited Warranty is the only warranty supplied by Blaze King, the manufacturer of the stove. All other warranties, whether express or implied, are hereby expressly disclaimed and purchaser's recourse is expressly limited to the Limited Warranty.
32. Blaze King and its employees or representatives will not assume any damages, either directly or indirectly, caused by improper usage, operation, installation, servicing or maintenance of this stove.
33. Blaze King reserves the right to make changes without notice. Please complete and mail the warranty registration card and have the installer fill in the installation data sheet in the back of the manual for warranty and future reference.
34. Blaze King is responsible for stocking parts for a maximum of seven (7) years after discontinuing the manufacture or incorporation of the item into its products. An exception to this would be if an OEM supplier is not able to supply a part.

**NOTES**

---

---

---

---

---

---

---

---

---

---

---

---

---

---

---

---

---

---

---

---

---

---

---

*Installer: Please complete the following information*

**Dealer Name & Address:** \_\_\_\_\_  
\_\_\_\_\_

**Installer:** \_\_\_\_\_

**Phone #:** \_\_\_\_\_

**Date Installed:** \_\_\_\_\_

**Serial No.:** \_\_\_\_\_