

Blaze King

Blaze King

QUALITY HEARTH PRODUCTS

INSTALLATION AND OPERATING INSTRUCTIONS

MODEL 2205 DIRECT VENT INSERT FIREPLACE

Dealer:
Installer:
Phone:
Installation Date:
Serial Number:



INSTALLER: PLEASE LEAVE THIS MANUAL WITH THE CUSTOMER
CUSTOMER: PLEASE KEEP INSTRUCTIONS FOR FUTURE REFERENCE

FOR YOUR SAFETY

DO NOT store or use gasoline or any other flammable vapors or liquids in the vicinity of this or any other appliance.

IF YOU SMELL GAS:

- Do not try to light any appliance.
- Open windows.
- Do not touch electrical switches.
- Do not use any phone in your building.
- Extinguish any open flame.
- Immediately call your gas supplier from a neighbor's phone. Follow the gas supplier's instructions.
- If you cannot reach the gas supplier, call the fire department.

PLEASE READ INSTRUCTIONS CAREFULLY BEFORE INSTALLING AND OPERATING THE APPLIANCE

WARNING: If the information in these instructions are not followed exactly a fire or explosion may result causing property damage, personal injury or loss of life.

Installation and service must be performed by a qualified installer, service agency or the gas supplier.

MANUFACTURED HOME REQUIREMENTS:

This appliance may be installed in an aftermarket permanently located, manufactured (mobile) home, where not prohibited by local codes.

This appliance is only for use with the type of gas indicated on the rating plate. This appliance is not convertible for use with other gases, unless a certified kit is used.

MANUFACTURED IN CANADA BY:

Valley Comfort Systems Inc.
1290 Commercial Way
Penticton, BC
V2A 3H5

Ph# 1-250-493-7444

Warnock Hersey



APPROVAL CERTIFICATION BY:

Warnock Hersey part of the:
Intertek Testing Services

MANUFACTURED IN USA BY:

Blaze King Industries
146A Street
Walla Walla, WA.
99362

Ph# 1-509-522-2730

CONTENTS

	Page
Introduction	3
Copy of certification label	4
Specifications	5
Appliance Description and Dimensions	6
Safety Notice	7
Planning Your Installation	8
Installation Instructions	9 - 14
Flush Mount Assembly Instructions	15 - 16
Door Installation & Removal	17
Log Installation	17
Wiring Diagrams	18
Operating Instructions	19 - 20
Important Information - Mineral Deposits	21
Maintenance	22 -23
Replacement Parts	24
APPENDIX 'A' (HIGH ALTITUDE)	25
APPENDIX 'B' (CONVERSION KITS)	26
APPENDIX 'C' (WARRANTY)	27 - 28
APPENDIX 'D' (TROUBLE SHOOTING)	29 -30

Mail your warranty card TODAY, and SAVE your BILL OF SALE. This card is included with the accessory package inside each firebox.

In order to receive full warranty coverage and to expedite service, BKI recommends that you save your bill of sale and attach it to this page.

By doing this you will have all the necessary information in the event that your stove may need service.

Your Blaze King Stove has its own personal serial number, no two stoves are alike. The serial number is located on the stove label attached to a plate in the slot below the viewing door..

INTRODUCTION

Thank you for purchasing the Blaze King Fireplace and welcome to the Blaze King family of products. It is our goal to satisfy every Blaze King customer. This owner's manual explains the steps required to safely assemble, install, operate, and maintain your new appliance.

The model 2205 is one of the most advanced gas fireplaces on the market. It is designed using the latest technology and manufactured to the highest quality.

Some of the many features are:

- ◆ Compact and easy to install.
 - ◆ Adjustable flame control for varying flame aesthetics and heat output.
 - ◆ Gas valve with remote capability, i.e. Optional wall mounted room thermostat or hand held remote control.
 - ◆ Standard heat activated convection fan with variable speed controller.
 - ◆ Standard simulated brick firebox lining.
 - ◆ Certified as a heating appliance with high efficiency. Therefore, the 2205 is suitable for continuous operation for zone heating.
 - ◆ Realistic three dimensional flowing flames with glowing four piece log set viewed through high temperature ceramic glass.
 - ◆ Heavy-duty construction for long life and durability.
 - ◆ Comprehensive warranty policy.
-

LISTING AND CODES

The Blaze King Model 2205 is listed and certified for installation in the U.S.A. and Canada under the following standards:

- ANSI Z21.88/CGA 2.22-2002, *Vented Gas Fireplace Heater.*
- CAN/CGA-2.17-M91, *Gas-Fired Appliances for Use at High Altitudes*

Please contact Blaze King, if you have any questions regarding the certification of this appliance.

BUILDING AND FIRE CODES, PERMITS AND INSPECTIONS:

The installation of this gas appliance must comply with your local building and fire codes. Always contact your local Building Inspector and/or Fire Department before beginning the installation process. If required, obtain a permit before installation and have the completed installation inspected. Remember that not complying with building and/or fire codes may jeopardize your homeowner's insurance. The model 2205 must conform with local codes or, in absence of local codes, with the *National Fuel gas Code, ANSI Z223.1/NFPA 54*, or the *Natural Gas and Propane Installation Code, CSA B149.1*.

MANUFACTURED HOME REQUIREMENTS:

This appliance may be installed in an aftermarket permanently located, manufactured (mobile) home, where not prohibited by local codes.

This appliance is only for use with the type of gas indicated on the rating plate. This appliance is not convertible for use with other gases, unless a certified kit is used.

COPY OF CERTIFICATION LABEL

Note: A copy of the certification label is provided here for your review. Due to constant up-grades it is possible that the information shown here may not coincide with the label as attached to the unit. In the event of a discrepancy between the labels, the label on the unit is considered as the correct one.

Warnock Hersey



Certified for U.S. and Canada
Certifié pour le Canada et les Etas-Unis

Project# 3038397

Listed Gas-Fired Vented Room Heater

BLAZE KING 2205

WH -

Natural Gas
Gaz Naturel

Propane Gas
Gaz Propane

Tested to ANSI Z21.88/CSA 2.33-2002, "Vented Gas Fireplace Heaters" also Tested to Canadian Standards (CAN/CGA-2.17-M91 "Gas-Fired Appliances For Use At High Altitudes")
Contrôlée par les normes ANSI Z21.88/CSA 2.33-2002, "Chauffrette à ventilation au gaz naturel ou propane"
aussi contrôlée par les Standards Canadiens (CAN/CGA-2.17-M91)

Direct Vented Gas Fireplace Heater	NATURAL GAS Gaz naturel	LP GAS Gaz propane
Input rating (BTU/hr / Kw) 0-610m 0-2000 ft Alt. for United States Evaluation de la consommation (BTU/hr / Kw) 0-610m 0-2000' d'altitude.	32,000 / 9.4	32,000 / 9.4
Orifice (DMS) 0-610 m for United States	36	53
Input rating (BTU/hr / Kw) 0-1372m 0-4,500 ft Alt. for Canada Evaluation de la consommation (BTU/hr / Kw) 0-1372m 0-4500' d'altitude	32,000 / 9.4	32,000 / 9.4
Orifice (DMS) 0-1372 m for Canada	36	53
Minimum Input (BTU/hr / Kw) Consommation minimale (BTU/hr / Kw)	17,000 / 4.97	17,000 / 4.97
Manifold Pressure (In w.c. / kPa) Collecteur de pression (In w.c. / kPa)	3.5 / 0.87	11.0 / 2.74
Manifold Pressure Lo setting (In w.c. / kPa) Collecteur de pression à bas rendement (In w.c. / kPa)	1.3 / 0.32	2.7 / 0.67
Minimum Inlet Pressure (In w.c. / kPa) Entree de pression minimale (In w.c. / kPa)	5.0 / 1.24	12.0 / 3.00

For natural gas when equipped with No. 36 orifice. For propane when equipped with No. 53 orifice.

VENTED GAS FIREPLACE- HEATER NOT FOR USE WITH SOLID FUEL. / NE PAS UTILISER AVEC DES COMBUSTIBLES SOLIDES

ONLY FOR DIRECT DISCHARGE WITHOUT DUCT CONNECTION / POUR DECHARGE DIRECTE SANS TUYAU DE CONNEXION. ALSO FOR USE IN MOBILE (MANUFACTURED) HOMES AFTER HOME IS ON SITE.

MAY BE INSTALLED IN A BEDROOM OR SITTING ROOM WHEN INSTALLED WITH A LISTED THERMOSTAT CONTROL IN CANADA. INSTALL AS PER ANSI Z223.1 IN THE USA.

AU CANADA CET A APPAREIL PEUT ETRE INSTALLE DANS UNE CHAMBRE A COUCHER OU UNE CHAMBRE MEUBLEE S'IL EST INSTALLE AVEC UNE COMMANDE DE THMOSTAT HOMOLOUEE. AUX ETATS-UNIS L'INSTALLER SELON LA NORME ANSI Z223.1

MINIMUM CLEARANCES TO COMBUSTIBLES / ESPACES MINIMUM REQUIS ENTRE L'APPAREIL ET DES MATÉRIEAUX COMBUSTIBLES.

Unit to Sidewall / De l'appareil au mur latéral 25.4 cm (10 in.)

Top trim to Mantel Height / Hauteur minimale du foyer 25.4 cm (10 in.)

40.6cm (16") Floor protection required (floor protection size diminishes as unit is raised up from the floor).

40.6cm (16") pouces de protection pour le plancher sont risqué.

For more details, see instruction Manual / Pour plus de détails, voir le mode d'emploi

Electrical Rating: 115 Volts, 0.7 Amp, 60 Hz / Consommation électrique: 115 Volts, 0.7 ampère, 60Hz

DANGER: Risk of electrical shock. Disconnect power before servicing unit. Do not route power cord beneath heater.

DANGER: Rique de choc électrique. Débrancher l'appareil avant de le reviser. Ne pas faire passer le fil d'alimentation électrique dessous la chauffrette.

Part No. 0719B fan or blower assembly may be used.

For installation in masonry fireplaces or any factory built fireplace listed to ULCS 610 in Canada & UL 127 in the United States.

This stove is factory equipped for 0-610m (0-2000 ft) in the United States.

Cette chauffrette est équipe en usine pour une elevation de 0 à 610m (0- 2000 pi).

This stove is factory equipped for 0-1372m (0-4500 ft) in Canada.

Cette chauffrette est équipe en usine pour une elevation de 0 à 1372m (0- 4500 pi).

This vented gas fireplace is not for use with air filters. FOR USE WITH GLASS DOORS CERTIFIED WITH THE APPLIANCE ONLY

This appliance is only for use with the type of gas indicated on the rating plate and may be installed in an aftermarket, permanently located, manufactured home (USA only) or mobile home, where not prohibited by local codes. See owner's manual for details. This appliance is supplied with a conversion kit.

Manufactured in Canada By: Valley Comfort Systems Inc.
Fabriqué au Canada par: 1290 Commercial Way
Penticton, B.C.
V2A 3H5 Canada

Manufactured in U.S.A. Blaze King Industries
Fabrique au U.S.A. par: 146A Street
Walla Walla, WA
99362 U.S.A.

Manufacture Date: / Date de fabrication:

<input type="checkbox"/> 2003	<input type="checkbox"/> 2004	<input type="checkbox"/> 2005	<input type="checkbox"/> 2006	<input type="checkbox"/> 2007
<input type="checkbox"/> JAN	<input type="checkbox"/> FEB	<input type="checkbox"/> MAR	<input type="checkbox"/> APRIL / AVRIL	<input type="checkbox"/> 2008
<input type="checkbox"/> MAY / MAI	<input type="checkbox"/> JUNE / JUIN	<input type="checkbox"/> JULY / JUIL	<input type="checkbox"/> AUGUST / AOÛT	<input type="checkbox"/> 2009
<input type="checkbox"/> SEPT	<input type="checkbox"/> OCT	<input type="checkbox"/> NOV	<input type="checkbox"/> DEC	<input type="checkbox"/> 2010

SPECIFICATIONS

MODEL 2205	Natural Gas (NG)	Propane (LP)
Manifold Pressure	1.3 - 3.5 in. w.c. (0.32 - 0.9 kPa)	2.7 - 11.0 in. w.c. (0.67- 2.75 kPa)
Min. Supply Pressure for Purpose of Input Adjustment	5.0 in. w.c. (1.2 kPa)	12.0 in. w.c. (3.0 kPa)
Max. Supply Pressure for Purpose of Input Adjustment	7.0 in. w.c. (1.8 kPa)	14.0 in. w.c. (3.5 kPa)
Orifice Size	36# DMS	53# DMS
Nominal Input Rating	32,000 BTU/hr	32,000 BTU/hr
Altitude	0 - 4,500 ft. (0 - 1372 m)	0 - 4,500 ft. (0 - 1372 m)
Primary Air Opening	1/4 in (Minimum).	1/4 in (Minimum).
Electrical Rating	120 V.A.C. System	120 V.A.C. System
Circulating fan	Variable Speed	Variable Speed
Vent System	Bi - axial (3" liner)	Bi - axial (3" liner)
Log Set	Ceramic (4 Piece)	Ceramic (4 Piece)

HIGH ALTITUDE INSTALLATION

When installing this appliance over 4500 ft (1372 m) above sea level in Canada, the appliance must be properly de-rated and installed according to local codes, in the absence of local codes in accordance with CAN/CGA-B149, in Canada. In the US for installations above 2000ft the appliance must be installed in accordance with the current National Fuel Gas Code, ANSI Z223.1/ NFPA 54 (see appendix 'A').

	Minimum Fireplace Opening
WIDTH	31 7/8"/810mm
HEIGHT	22"/559mm
DEPTH	17"/432mm

Note: See page 8 for detailed dimension and clearance information.

APPLIANCE DESCRIPTION & DIMENSIONS

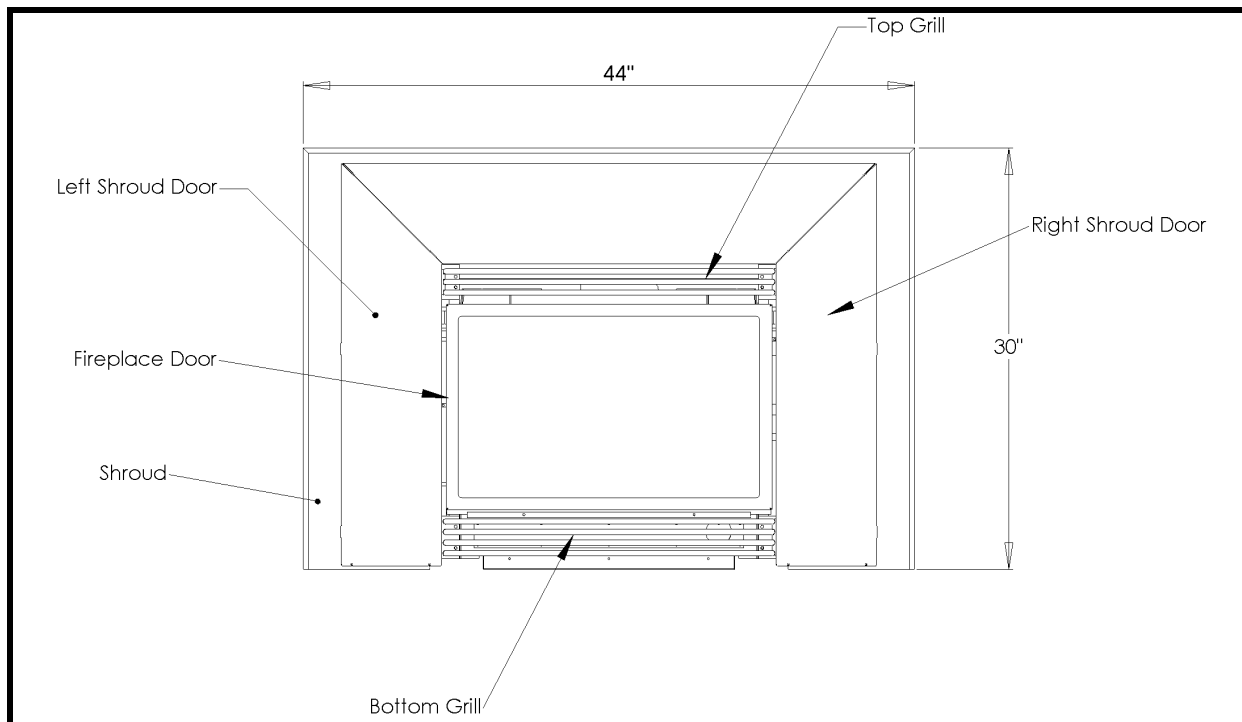

APPLIANCE DIMENSIONS

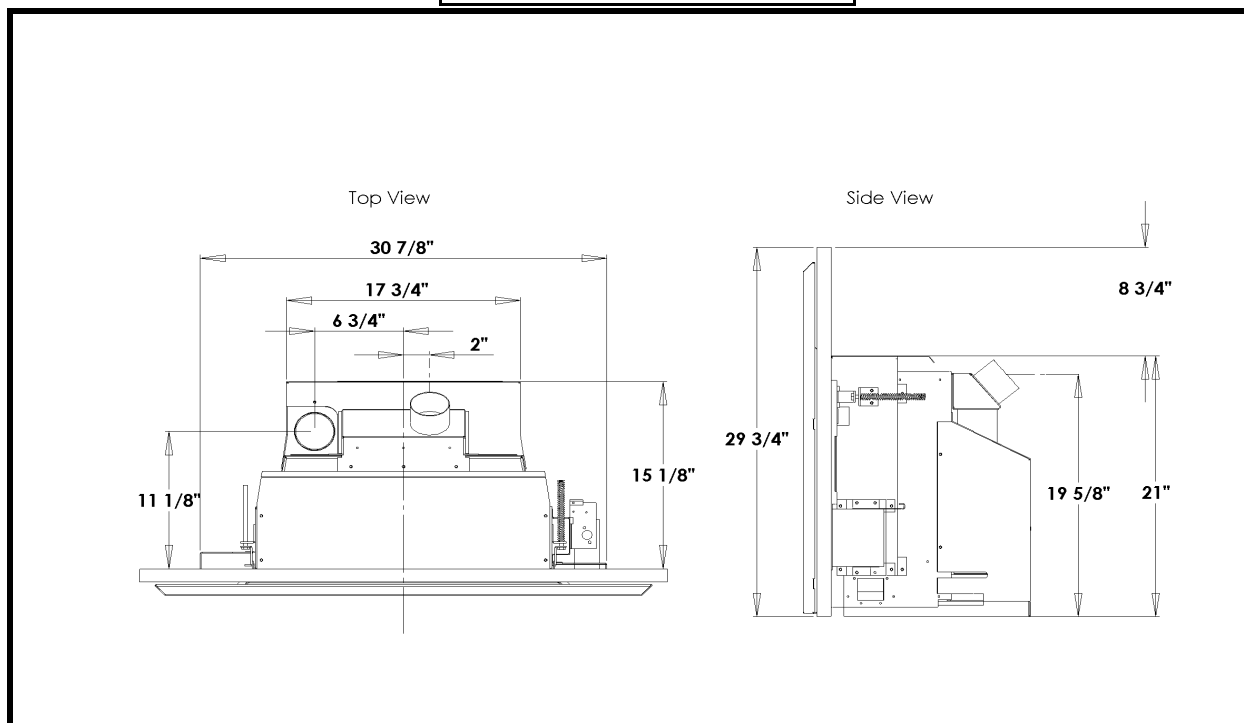

SAFETY NOTICE

IF THIS APPLIANCE IS NOT PROPERLY INSTALLED, A HOUSE FIRE, OR EXPLOSION MAY RESULT. FOR YOUR SAFETY, FOLLOW THE INSTALLATION DIRECTIONS. CONTACT LOCAL BUILDING OR FIRE OFFICIALS ABOUT RESTRICTIONS AND INSTALLATION REQUIREMENTS IN YOUR AREA. PLEASE READ THIS ENTIRE MANUAL BEFORE YOU INSTALL AND USE YOUR NEW APPLIANCE. FAILURE TO FOLLOW INSTRUCTIONS MAY RESULT IN PROPERTY DAMAGE, BODILY INJURY OR DEATH.

- ◆ NEVER vent the appliance into other rooms or buildings. The appliance must be vented ONLY to the outside.
- ◆ Fire Extinguisher: Every home should have at least one fire extinguisher. An approved Class A-B-C extinguisher should be mounted on the wall near an exit and close to the appliance, but not so close that accessibility to the extinguisher could be blocked by a fire. Your local Fire Department can advise you concerning the most appropriate location.
- ◆ Smoke Detectors & Carbon Monoxide Detectors: Install at least one smoke detector on each floor of your home to ensure your safety. It should be located away from the gas appliance and close to the sleeping areas. Follow the smoke detector manufacturers placement installation and maintenance instructions. Your local Fire Department may provide assistance in selecting smoke detectors and CO-detectors. It is strongly recommended, for your family's protection, that a CO-detector be placed in all homes that utilize gas in any form.
- Clothing or other flammable materials should not be placed on or near the appliance.
- ◆ The flexible cord provided connected to a line voltage electrical supply.
- ◆ Any safety screen or guard removed for servicing a room heater must be replaced prior to operating the appliance.
- ◆ Installation and repair should be done by a qualified service person.
- ◆ The appliance and venting should be inspected before use by a qualified person and have inspections by a qualified service person annually.
- ◆ More frequent cleaning may be required due to excessive lint from carpeting, bedding materials, etc.
- ◆ It is imperative that control compartments, burners, & circulating air passageways of the appliance are kept clean.
- ◆ To clean the stove, make sure the appliance is off and cold. Then remove the logs and embers and use a vacuum to clean burner and air openings in the bottom and back of the appliance. Replace the logs and embers.

SAFETY PRECAUTIONS FOR THE INSTALLER

- 1) **Wear gloves and safety glasses for protection.**
 - 2) **Exercise extreme caution when using ladders or when on roof tops.**
 - 3) **Be aware of electric wiring locations in walls and ceilings.**
 - 4) **Use a back support when doing any heavy lifting.**
- ◆ Do not use this heater if any part has been under water. Immediately call a qualified service technician to inspect the heater and to replace any part of the control system and any gas control which has been under water.
 - ◆ The flow of ventilation air must not be obstructed. Adequate clearances must be maintained around the bottom grill to provide for adequate ventilation air.
 - ◆ Due to high temperatures, the appliance should be located out of traffic and away from furniture and draperies.
 - ◆ Children and adults should be alerted to the hazards of high surface temperatures and should stay away to avoid burns or clothing ignition.
 - ◆ Young children should be carefully supervised when they are in the same room as the appliance .

PLANNING YOUR INSTALLATION

MANUFACTURED / MOBILE HOME REQUIREMENTS

This appliance when installed must be electrically grounded in accordance with local codes or, in the absence of local codes the National Electrical code ANSI/NFPA 70 in the U.S.A or the current CAN/CGA B149 Installation Code and the current Canadian Electrical code CSA C22.1 in Canada.

- ◆ Ensure as in any installation, that structural members are not cut or weakened during installation .

PLANNING YOUR INSTALLATION

Please note the following key points regarding the location of your appliance.

- ◆ This appliance requires a dedicated masonry fireplace or factory built fireplace, built to ULCS 610 in Canada & UL 127 in the United States, to run the two 3" liners down (see vent installation on page 10 & 11).
 - ◆ A sufficient gas pressure is required to supply the unit with a minimum of 5.0" W.C. for natural gas and 12.0" W.C. for LPG (see gas installation on page 12 –13).
 - ◆ Allow adequate accessibility clearances for servicing and proper operation.
- A suitable power outlet is required to provide power to the fan.

CLEARANCES

MINIMUM FIREPLACE DIMENSIONS

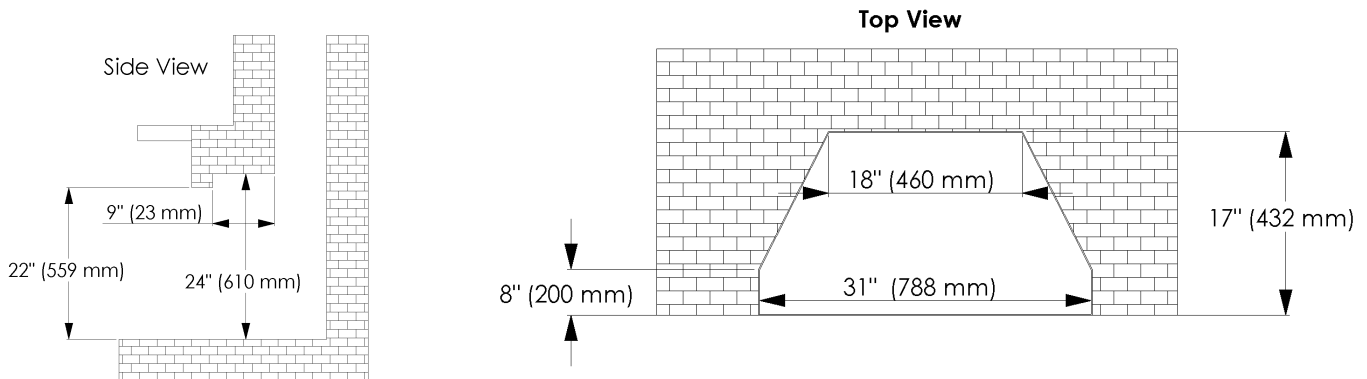

Minimum Clearance to combustibles must be maintained as outlined in this manual

WARNING: Failure to position the parts in accordance with these diagrams or failure to use only parts specifically approved with this appliance may result in property damage or personal injury.

Be sure to leave adequate accessibility for servicing and proper operation.

CAUTION: This appliance is designed for use in a factory built solid fuel burning fireplace meeting the requirements of ULCS 610 in Canada & UL 127 in the United States. It cannot be enclosed by combustible material and used as a built-in gas fireplace.

CLEARANCES TO COMBUSTIBLES

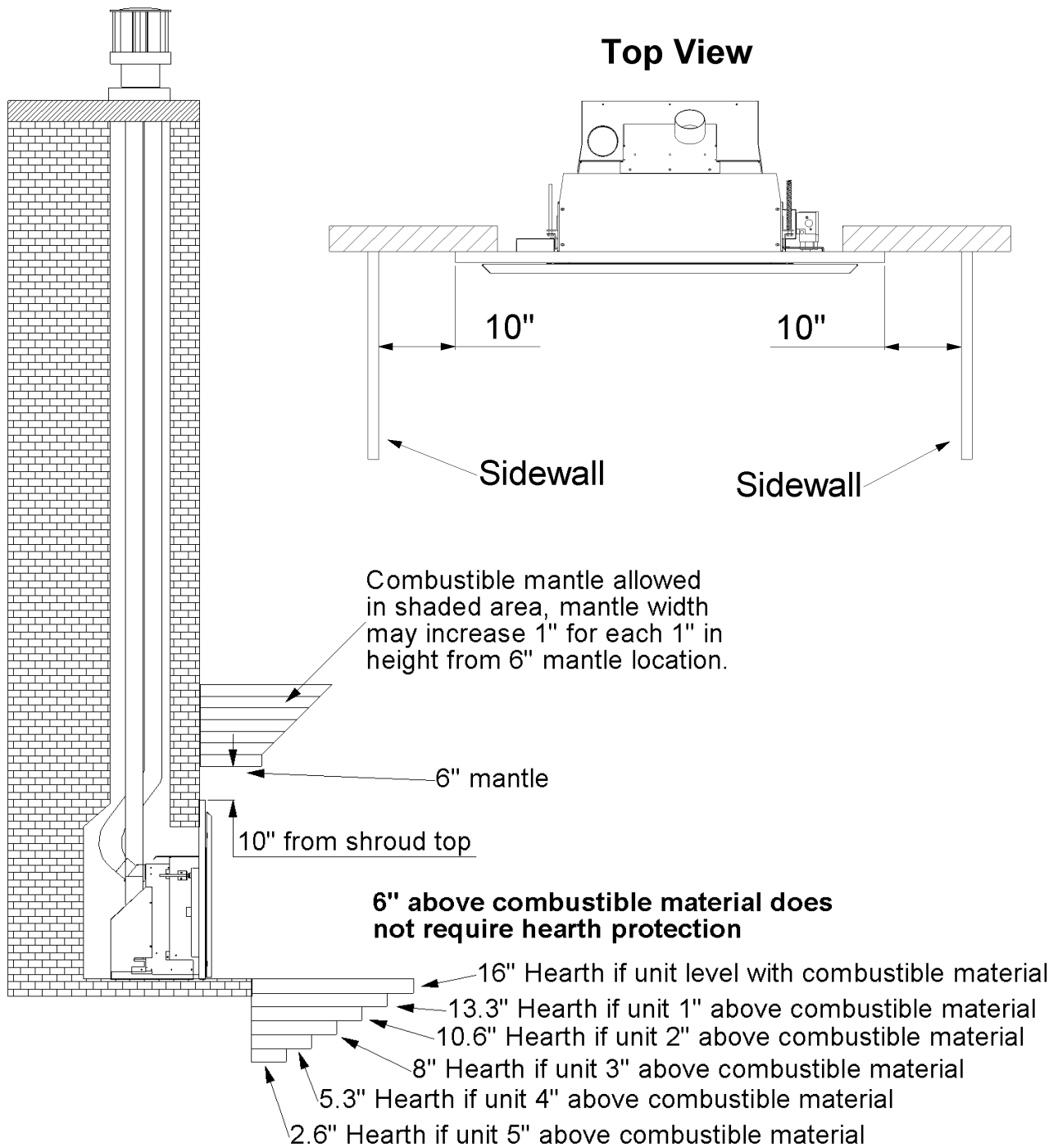

INSTALLATION

VENTING

Please follow the venting instructions as strictly as possible to obtain the best performance from the appliance.

THESE ARE THE ONLY VENTING COMPONENTS APPROVED FOR USE WITH THE MODEL 2205.

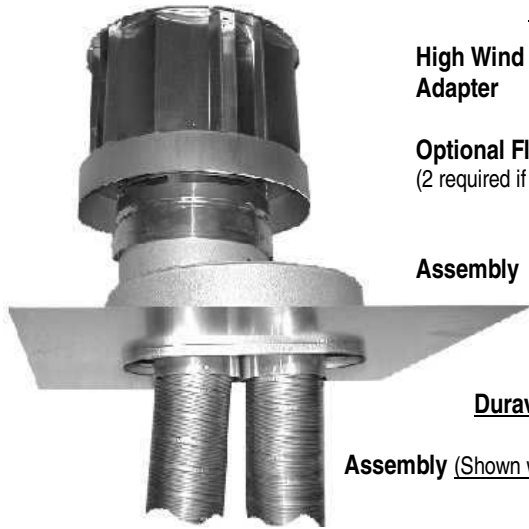

Duravent Product Numbers:

High Wind Cap Adapter	#991
	#923GK
Optional Flex Connectors (2 required if used)	#2150
Security Chimney Assembly	#3PDVCV

Duravent Assembly
(Shown with high wind cap)



Security Chimney Assembly
(wind cap)

VENT ASSEMBLY

Only use approved 3" double walled flex liner for correct installation

The exhaust and air intake pipe must be securely fastened to the appliance and terminal and all joints must be secured using a minimum of 3 screws evenly spaced around the pipe.

Approximately 1" from the end of the 3" appliance exhaust pipe outlet at the appliance air intake pipe and at the 3" terminal connections apply a bead of Mil Pac or other high heat silicone 1/4" wide. Slide the 3" pipe onto the appliance and secure with 3 screws evenly spaced to the outlet.

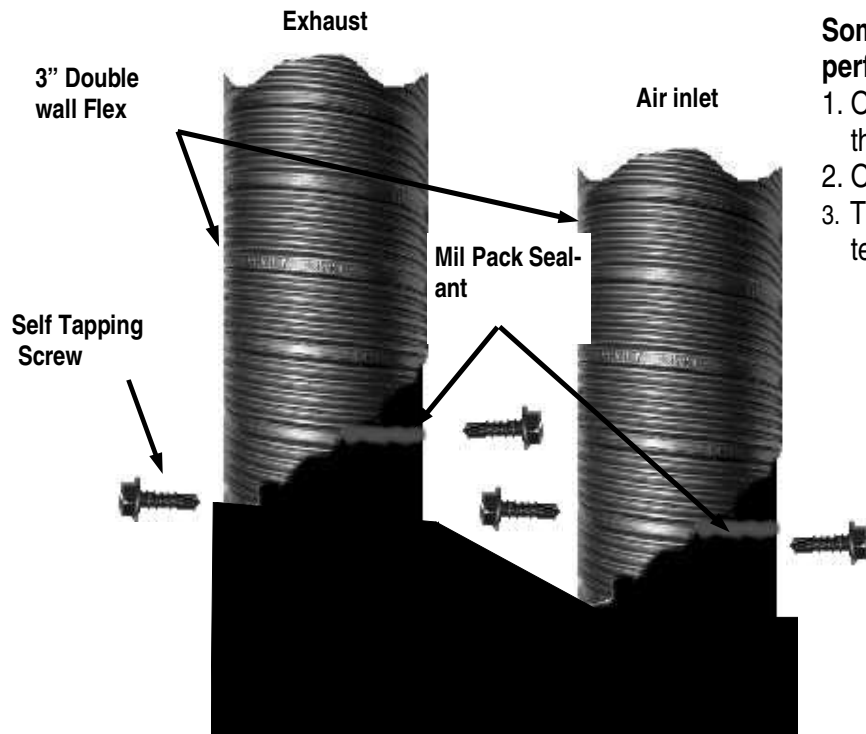

Some general venting rules for best venting performance:

1. Observe local code restrictions, if any, regarding the installation of this type of gas appliance.
2. Observe the venting chart on the following page.
3. Terminate the vent with a suitable vent termination.

When installed in accordance with the manufacturer's instructions the combustion air supply will be in the same pressure zone as the vent outlet.

This direct vent appliance must be installed using an approved venting system. All vent pipe joints must be sealed with a high temperature sealant in order to meet the ANSI/CSA leakage limit standards.

INSTALLATION (DIRECT VENT)

This appliance must not be connected to a chimney flue serving a separate solid-fuel burning appliance.

VENTING CHART

The model 2205 is only certified for vertical terminations.

“WARNING: Failure to position the parts in accordance with these diagrams or failure to use only parts specifically approved with this appliance may result in property damage or personal injury”.

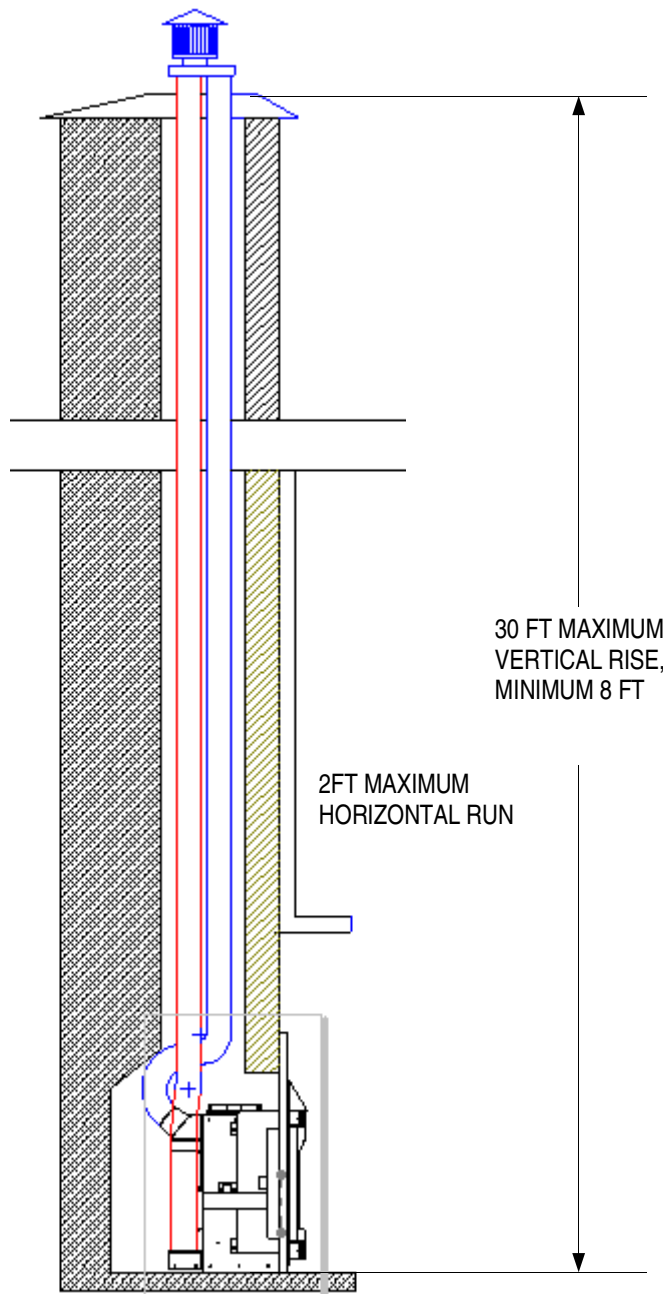

Exhaust
Connector Intake
Connector

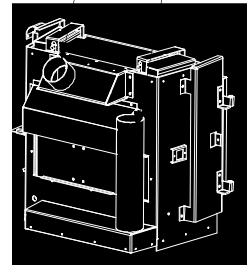

VENT TERMINAL CLEARANCES

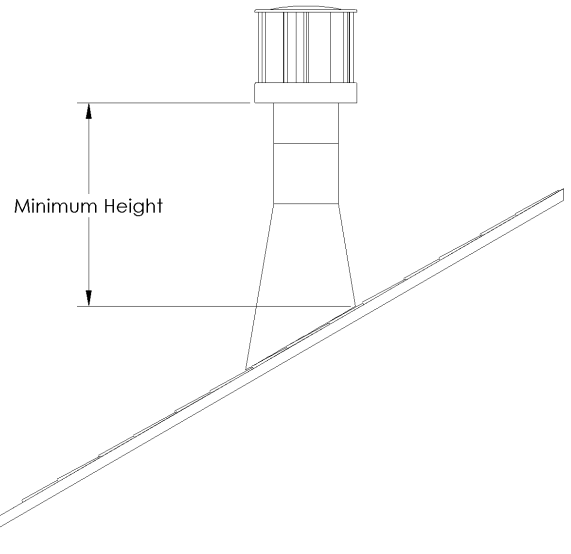

Consult local codes for minimum vent cap height above the roof (X), vent must be a minimum of 2' from any wall.

Refractory material, glass doors, screen rails, screen mesh and log grates can be removed from the fireplace before installing the gas fireplace insert. Smoke shelves, shields and baffles may be removed if attached by mechanical fasteners. Trim panels or surrounds shall not seal ventilation openings in the fireplace.

The fireplace flue damper can be fully blocked open or removed for installation of the gas fireplace insert. The fireplace and chimney must be clean and in good working order and constructed of non-combustible materials. Chimney cleanouts must fit properly.

INSTALLATION (GAS SUPPLY)

ONLY PERSONS LICENSED TO WORK WITH GAS PIPING MAY MAKE THE NECESSARY GAS CONNECTION TO THIS APPLIANCE. YOU ARE NOW READY TO HOOK UP THE GAS SUPPLY. BE SURE GAS PLUMBING INSTRUCTIONS AND ALL PROVINCIAL AND LOCAL CODES ARE CAREFULLY FOLLOWED. USE APPROVED FLEXIBLE GAS CONNECTIONS OR RIGID PIPING, DEPENDING ON PROVINCIAL AND LOCAL CODES, TO ATTACH BURNER TO GAS SUPPLY. BE SURE TO USE PROPER SIZE GAS SUPPLY LINE. CAREFULLY CHECK ALL CONNECTIONS WITH A SOAP AND WATER SOLUTION FOR GAS LEAKS. EACH INSTALLATION MUST CONFORM TO ALL LOCAL, PROVINCIAL AND NATIONAL CODES. REFER TO THE NATIONAL FUEL GAS CODE, LOCAL ZONING AND CODE AUTHORITIES FOR DETAILS ON INSTALLATION REQUIREMENTS.

EXISTING GAS SUPPLY

Before interrupting the existing gas supply it is recommended that the following be checked.

- ◆ Shut down all gas appliances and carry out a pressure test to insure there are no existing leaks on the system.
- ◆ Before connecting the appliance to the gas supply line, double check that the appliance you have purchased is designed for the gas type you are using. The gas type markings are located on the certification label and also on the appliance's gas valve.
- ◆ Check the gas pressure to insure you will be able to supply the minimum inlet pressure for the appliance (see page 12).
- ◆ Check your pipe sizing to insure sufficient volume will be supplied to the appliance.

GAS SUPPLY INSTALLATION

Provide adequate clearance for proper installation and checking of the gas connections.

Have your gas supplier or a qualified gas fitter run a gas supply line into the gas fireplace. The line must be properly sized and fitted according to the installation codes. Up stream of the appliance supply connection, the fitter shall provide an easily accessible manual shut-off valve.

The appliance and its individual shut-off valve must be disconnected from the gas supply piping system during any pressure testing of that system at test pressures in excess of 1/2 psi (3.5 kPa). The appliance must be isolated from the gas supply piping system by closing its individual manual shut-off valve during any pressure testing of the gas supply piping system at test pressures equal to or less than 1/2 psi (3.5 kPa). Failure to do so will damage the appliance's gas valve. Such damage is not covered by the manufacturer's warranty.

Check for proper gas supply pressure by loosening the set-screw on inlet pressure tap (marked **IN**) on the gas valve with a small flat tip or Phillips screw driver and placing a test gauge on the tap.

The minimum permissible gas supply pressure is 5.0 in. w.c. (1.24 kPa) for natural gas and 12.1 in. w.c. (3.00 kPa) for propane. Maximum gas supply pressure should never exceed 14.0 in. w.c. (3.48 kPa) or 1/2 psi. for both natural gas and propane.

BE SURE TO TIGHTEN THE PRESSURE TAP SET-SCREW AFTER CHECKING THE PRESSURE. CHECK ALL GAS CONNECTIONS FOR GAS LEAKS.

INSTALLATION

PIPING DETAIL

Gas Connection:

- ◆ The gas connection supplied is a 1/2" flare connection. The supply pipe can be either rigid or listed flexible connection and/or copper tubing if allowed by state, provincial and local codes.
- ◆ In the USA follow local codes and/or the current National Fuel Gas Code, ANSI Z223.1.
- ◆ In Canada consult local authorities and the CAN/CGA B149 installation codes.
- ◆ Provide a union downstream of the appliance shut-off valve to allow disconnection of the burner assembly for servicing.

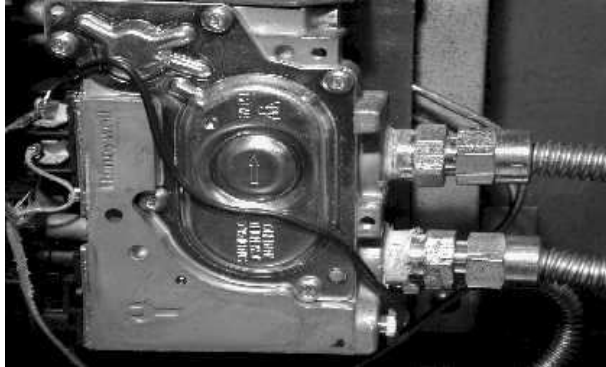

High Altitude:

- ◆ In the USA the model 2205 is approved for altitudes up to 2000 feet using the factory installed burner orifice. At elevations above 2000 feet, U.S. codes require a decrease in the input rating by replacing the burner orifice. The input should be reduced by 4% for each 1000 feet above sea level (see appendix 'A'). Check local gas utility for orifice size identification.
- ◆ In Canada the model 2205 is approved for altitudes up to 4,500 feet (1375 meters). For altitudes above 4,500 feet (1375 meters) consult the local codes for correct de-rating.

Note: The difference in altitude rating is a requirement of certification standards.

GAS SUPPLY PRESSURE			
Natural Gas	Minimum 5.0"w.c	Maximum 10.5"w.c	Recommended 7"w.c
LP GAS	Minimum 12.1"w.c	Maximum 14.0"w.c	Recommended 12.5"w.c

IMPORTANT:

Always check for gas leaks with soap and water solution or gas leak detector. Do not use open flame for leak detection.

INSTALLATION

AERATION ADJUSTMENT

IMPORTANT: Aeration adjustment is critical to the correct functioning of the appliance. Carbon build up, flame lift or any malfunction due to the aeration not being correctly adjusted during installation is **NOT** covered under the warranty

FACTORY SETTING

Natural Gas	1/4" (6.35 mm) Open
LP GAS	1/4" (6.35 mm) Open

Note: Aeration is factory set, but may need adjustment

CAUTION: Parts requiring adjustment during operation may be hot.

To adjust the air shutter:

- Loosen screw on round access panel & rotate open.
- Use supplied adjusting rod and insert into air shutter.
- Turn adjuster clockwise or counter clockwise as required.

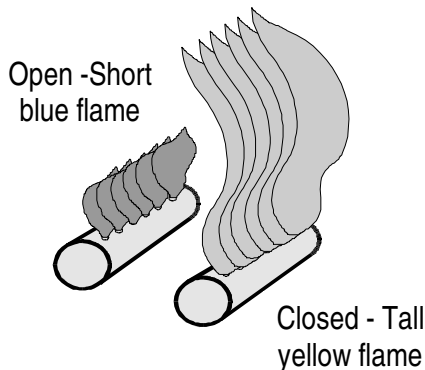

OPTIONAL THERMOSTAT

WARNING: The gas valve of this appliance operates on a millivolt system and is not intended to be connected to main power.

If required, a wall thermostat may be installed. Blaze King provides a thermostat but any CSA, ULC or UL approved 250-750 millivolt rated non-anticipator type thermostat may be used. It is important to use the correct gauge wire when installing your thermostat.

See wiring diagrams in on page 16 for details on valve connections.

Note: When installing a remote control or wall switch use the correct gauge of wire. See table below.

Wire Size	Max. Length
14 GA.	50 FT.
16 GA.	32 FT.
18 GA.	20 FT.
20 GA.	12 FT.
22 GA.	9 FT.

Burner Flame



SHROUD KIT & GRILL ROD KIT INSTALLTION

**ONLY USE TRIM KIT (PART# Z2223) SUPPLIED BY THE MANUFACTURER
REMOVE ALL PROTECTIVE COATING FROM GOLD PLATED SURFACE AFTER SHROUD INSTALLATION IS COMPLETE,
BUT PRIOR TO FIRING THE STOVE! UPPER AND LOWER AIR INTAKE OPENING MUST NOT BE COVERED OR BLOCKED**

Shroud Installation

Step 1

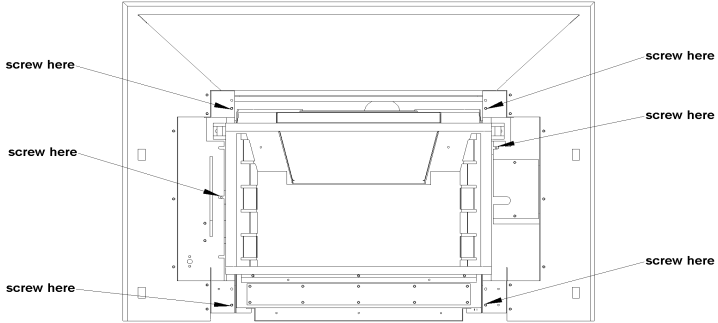

Side doors not shown for illustration purposes

Once all the venting and gas is completed install the shroud.

Grill Rod Kit Installation

Step 2

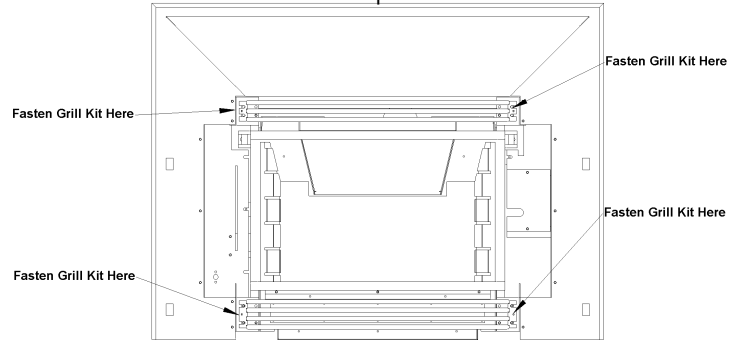

Side doors not shown for illustration purposes

After the unit has been installed it is time to install the shroud & grill rod kits. Remove the viewing glass retainer and glass, use caution they are not attached to each other. Remove the shroud left side panel from the shroud and attach the label plate holder with 2 screws and attach the panel to the unit with one screw. Be sure to pull the label plate through the slot in the panel and route the cable so it's not catching on anything. Now attach the rheostat to the left side panel. Place the shroud face down in front of the unit being careful not to damage the paint and plug the power cord and the on/off switch into the 2 wires on each side of the unit. Carefully stand the shroud up and attach to the unit with all remaining screws, it might be necessary to loosen some of the mounting brackets where attached to the shroud to allow for some screw hole alignment. Now reinstall the viewing glass and the glass retainer see page 17.

The next step is to mount the upper and lower grill rod kits. They are fasten with 2 screw per side to the grill mounting brackets as shown above. Note that the 3 rod section is installed on the top and the 4 rod section is installed on the bottom. Be sure to center the grill rods so you don't run into trouble in step 3.

Grill Mounting Cover Installation

Step 3

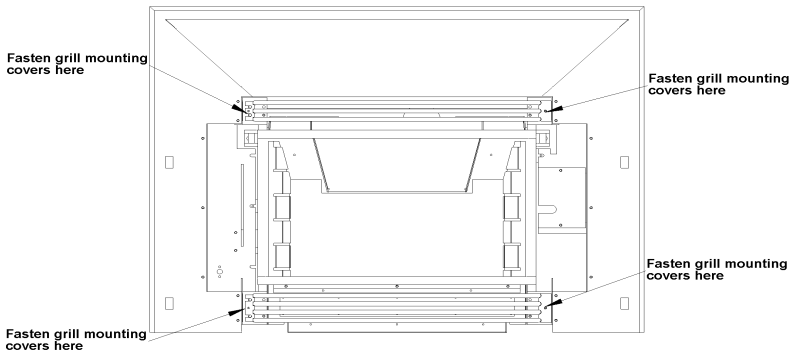

Side doors not shown for illustration purposes

After the grill rod kits have been installed it is time to fasten the grill mounting covers over the grill mounting brackets. These covers are secured with 1 screw per side as shown above.

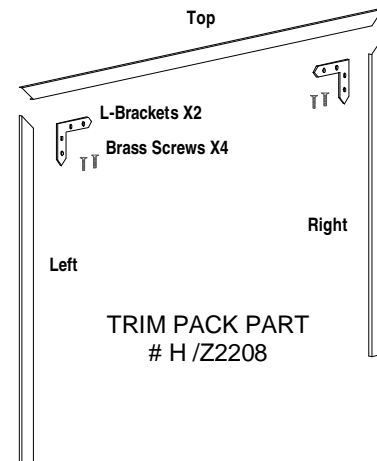

The final step is to install the trim pack around the perimeter of the shroud kit. Fasten the 3 pieces together with the L-brackets, as shown above, and slide the now 1 piece trim pack down over the outside edges of the shroud kit. Remove all protective coating from the gold plated surfaces. See next page for picture of finished installation.

SHROUD KIT & GRILL ROD KIT INSTALLTION

Finished Shroud Kit Installation

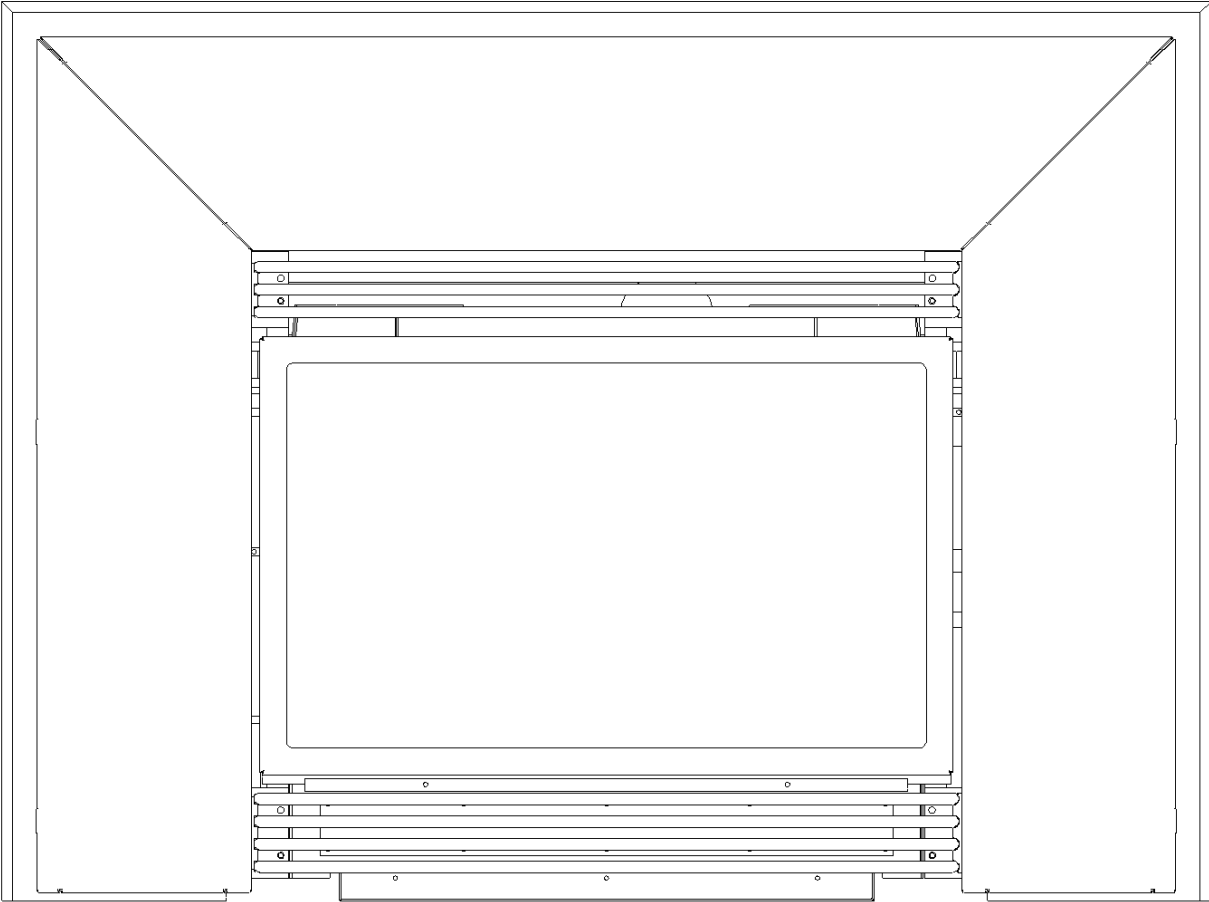

Door installation & removal / log installation

TO OPEN DOOR

CAUTION:

Do not abuse the appliance's glass by striking, slamming or similar action. Do not use the appliance with the door removed, glass panel cracked or broken. Only use approved 5mm ceramic glass for use with this heater. Do not use substitute materials. Replacement of the panel should only be carried out by a licensed qualified service person.

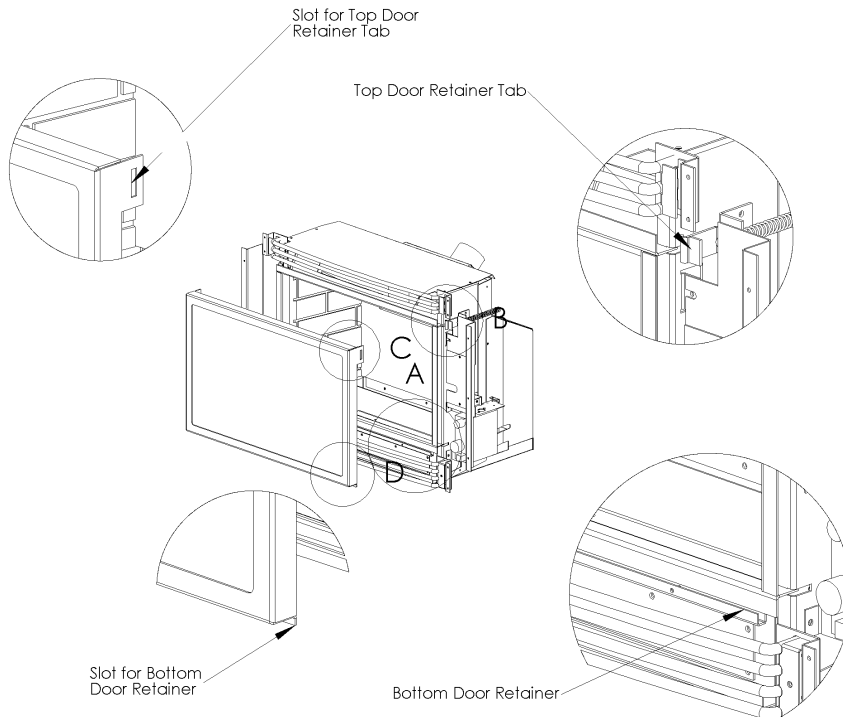

Door Installation

To install door slide bottom door lip into bottom door retainer bracket. The next step is to lift the door, slightly, into place and insert the door retainer tabs, located on each side of the unit, into the slots at the top on each side of the door. Pull the door out slightly at the top and release to ensure that the unit is sealed. See picture for more details.

LOG INSTALLATION

CAUTION: Only the log set supplied by the manufacturer may be used with this appliance. The log set **MUST** be installed as described in this manual.

WARNING: Dangerous operating conditions may occur if these logs are not positioned in their approved locations. If logs are broken, do not operate the unit until they are replaced.

Note:

If the user desires the installation of the twigs may be reversed. The twigs must remain on the side that they are intended for but are able to be installed as shown in picture 5 or as in picture 7.



1

2

3



4

5

6



7

WIRING DIAGRAMS

THIS MOBILE/MANUFACTURED HOME APPROVED APPLIANCE MUST BE GROUNDED TO THE STEEL CHASSIS OF THE HOME WITH A 8 GAUGE COPPER WIRE USING A SERRATED OR STAR WASHER TO PENETRATE PAINT OR PROTECTIVE COATING TO INSURE GROUNDING.

Observe good wiring practice: Label all wires prior to disconnection when servicing controls. Wiring errors can cause damage to the unit and may cause dangerous operation. Verify proper operation after servicing.

WARNING: Electrical Grounding Instructions

This appliance is equipped with a three-prong (grounding) plug for your protection against shock hazard and should be plugged directly into a properly grounded three-prong receptacle. Do not cut or remove the grounding prong from this plug.

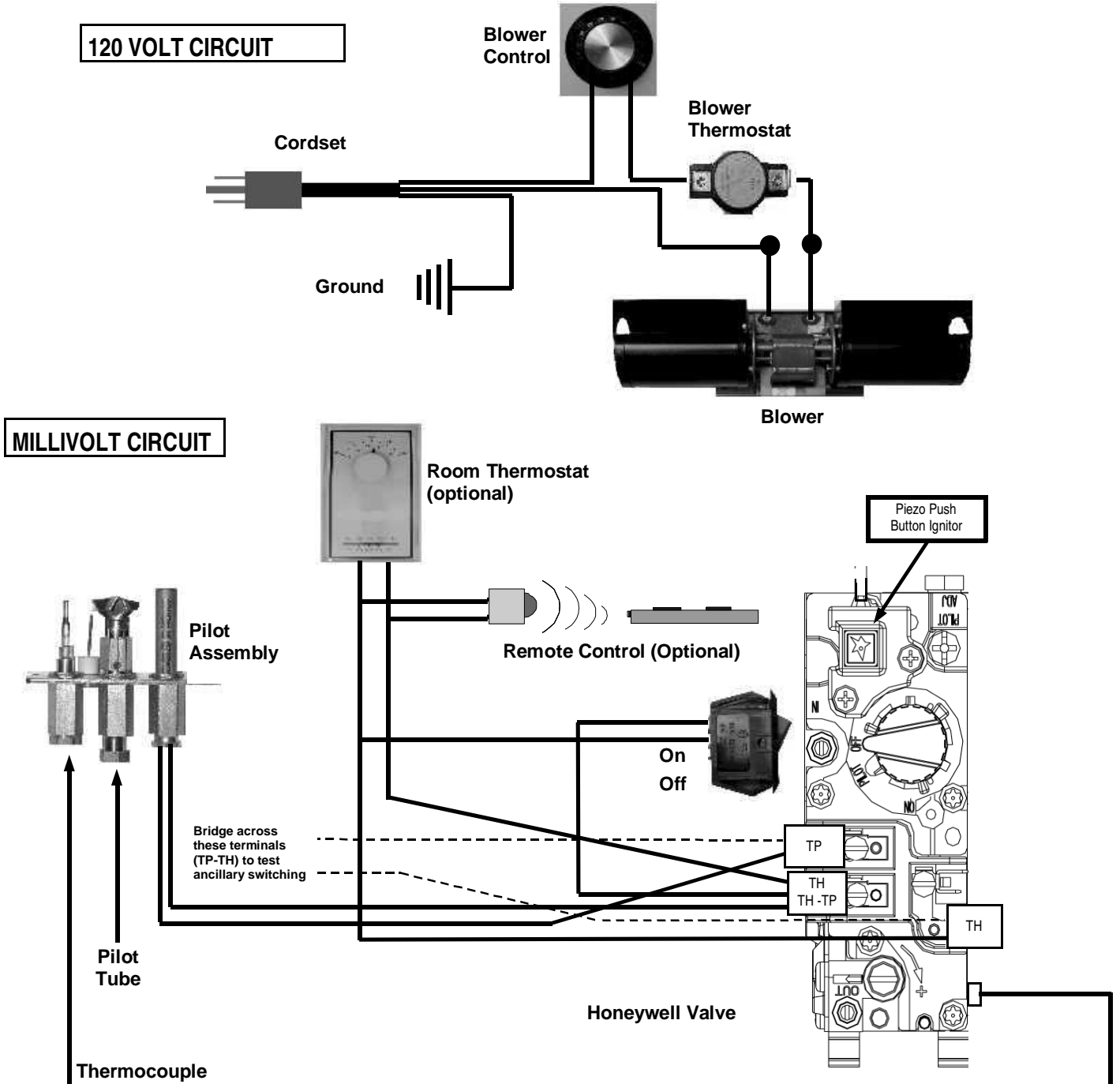

OPERATING INSTRUCTIONS—PRE-START UP CHECK LIST

FOR YOUR SAFETY READ - BEFORE LIGHTING

WARNING: IF YOU DO NOT FOLLOW THESE INSTRUCTIONS EXACTLY, A FIRE OR EXPLOSION MAY RESULT CAUSING PROPERTY AND/OR PERSONAL INJURY

DO NOT: Use tools to operate controls, only use your hand to push in and turn the controls.

DO NOT: Try to repair the appliance. Call a qualified service technician.

DO NOT: Use this appliance if any part has been under water. Immediately call a qualified service technician to inspect the appliance and replace any part of the gas control system which has been under water.

DO NOT: Use this appliance if you smell gas.

WHAT TO DO IF YOU SMELL GAS:

- ◆ OPEN WINDOWS.
- ◆ DO NOT TOUCH ANY ELECTRICAL SWITCH; DO NOT USE THE PHONE IN YOUR BUILDING.
- ◆ EXTINGUISH ANY OPEN FLAME.
- ◆ IMMEDIATELY CALL YOUR GAS SUPPLIER FROM A NEIGHBOR'S PHONE AND FOLLOW THE GAS SUPPLIER'S INSTRUCTIONS.

FINAL CHECK

INSTALLER: Before leaving the appliance with the customer, you must check the operation of the appliance:

- ◆ Thoroughly check the entire appliance for gas leaks.
- ◆ Check correct rating by clocking the appliance at 15 minutes (see label).
- ◆ Check flame picture. Adjust primary air if required (see page 14).
- ◆ Take time to go through the unit with the customer.

◆ NOTE: When first fired, the unit will produce an odor. This is normal and is part of the paint curing process. It is recommended that you open a few windows to ventilate the room. This will be noticeable for at least 6 hours. During the first hour smoke detectors in the house may be set off.

◆ Following the initial burn-in period, the glass panel may require cleaning.

◆ **CAUTION: Do not clean the glass when the appliance is hot!**

◆ When the appliance is fired from cold the glass may fog up. This is due to condensations and is normal.

◆ Make yourself familiar with these instruction before operating the appliance.

◆ Check any loose electrical wires that may cause a shock.

◆ Check around the appliance for gas leaks. IF YOU SMELL GAS, follow the instructions on the front cover of this manual.

◆ Check to see that logs are correctly positioned. The pilot light should be visible.

◆ Check to make sure that venting is secure.

◆ Check all external parts, such as grills, doors and control cover are properly attached and fastened.

◆ **CAUTION: Do not turn the unit off and on again within a minimum of a 60 second wait.**

START-UP PROCEDURE

1. Set the thermostat, if present, to the lowest level. Switch burner switch to **OFF**. Set the flame adjustment knob to the **HI** position. Press slightly and turn the control knob clockwise  to the **OFF** position and wait 5 minutes; thus allowing any gases to escape which may have accumulated in the combustion chamber. **IF YOU SMELL GAS STOP! FOLLOW INSTRUCTIONS ON PAGE 19.**

(**Note:** LP gases do not vent upward). Then follow steps 2 and 3 to establish pilot.

2. Press slightly and turn control knob counterclockwise  to **PILOT** position; depress control knob and light pilot by repeatedly pressing the sparker. Venting of air may take place at the pilot prior to the flow of fuel gases. Once flame is established, hold knob depressed for approximately 60 sec.

3. Release knob. If the pilot will not light or the control knob does not pop up when released, turn the control knob to **OFF** and call your service technician or gas supplier. If the pilot should go out, turn the control knob to **OFF** position and repeat steps 1, 2 and 3.

Note: this will allow reset of INTERLOCK for proper lighting of pilot.

Also the Honeywell valve is equipped with a safety lockout, once in the off position you must wait until the thermopile has cooled down before attempting to light the pilot (approximately 3 minutes).

4. Press and turn control knob counterclockwise  to **ON** position.
5. Turn flame and heat adjustment knob to the desired comfort level from **HIGH** to **LOW**.
6. Turn thermostat to the desired comfort level or turn ON/OFF switch to the ON position.

OPERATING INSTRUCTIONS

TEMPORARY SHUT-DOWN

To turn off the main burner only, set the thermostat to the lowest setting or turn switch to **OFF**. Press and turn the knob clockwise ↻ to **PILOT** position.

COMPLETE SHUT-DOWN

Press and turn the knob clockwise ↻ to the **OFF** position.

CONTROL KNOB POSITIONS

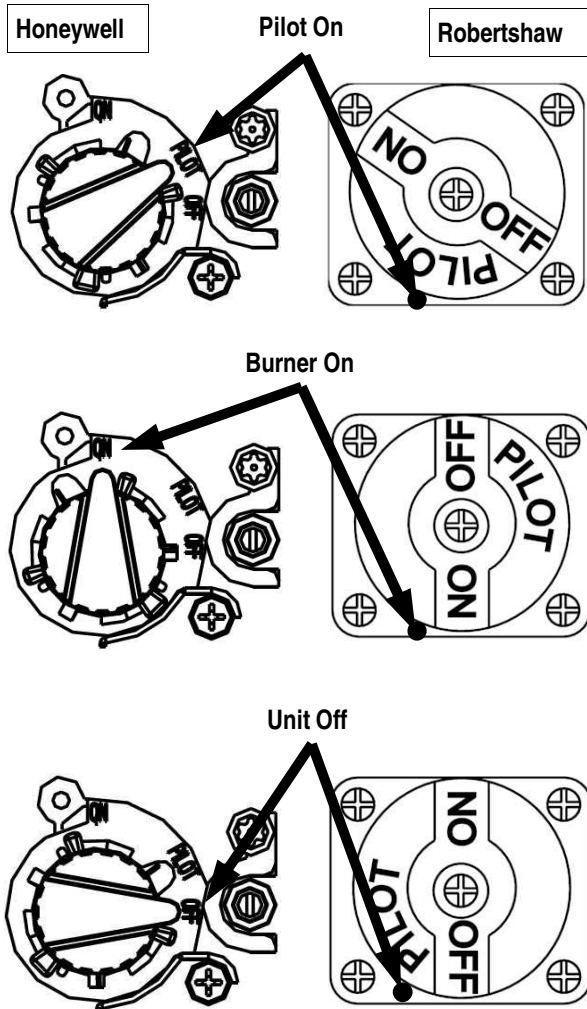

CONVECTION FAN OPERATION

- ◆ The convection fan speed control is located adjacent to the gas controls. Turning the control knob all the way anticlockwise will turn off the convection fan. Adjust the blower speed to the desired speed.

NOTE: The fan will turn on once the unit has reached operating temperature. This prevents the discharge of cold air.

NORMAL OPERATING SOUNDS

- ◆ **FIREBOX:** You may hear some cracking or ticking sounds on start-up and shut-down. This is due to the expansion and contraction of the steel in the firebox.
- ◆ **BLOWER:** We use high efficiency fans in our appliances. You may hear a whirring sound when the fan turns on. This will decrease or increase depending on the speed setting of the fan.
- ◆ **PILOT FLAME:** You may detect a very slight whisper sound from the pilot when it is turned on.
- ◆ **These are all normal sounds associated with this type of appliance and should not be considered as defects.**

IMPORTANT - WHITE MINERAL DEPOSITS

One of the byproducts of the combustion process in a gas appliance, is a mineral which can show up as a white film on the ceramic glass of the viewing door. The composition of the deposit varies widely from various locations and also from time to time in the same location. You may have the problem for a time and then not see it for many months when it will reappear in your area. It seems this is associated with the varying sulfur content of the gas. We have discussed this problem with ceramic glass manufacturers and they cannot give us a definitive answer to this problem. Dealers have tried various cleaning products with varying results. The following recommendations will not guarantee results in your particular case.

1. Clean the glass regularly as soon as you notice the buildup (white film). If the film is left for a longer period of time, build up will bake on. It is then much harder, if not impossible, to remove.
2. NEVER use an abrasive cleaner on the ceramic glass. Any abrasion of the surface has the immediate effect of lessening the strength of the glass. An emulsion type cleaner is recommended.
3. Use a soft damp cloth to apply the cleaner. Dry the glass with a soft, dry, preferably cotton cloth. Most paper towels and synthetic materials are abrasive to ceramic glass and should be avoided.
4. Our dealers have had good results from the products listed below. We can not however guarantee the results of these products.

a) BRASSO

b) POLISH PLUS by KEL KEM

c) COOK TOP CLEAN CREME by ELCO

d) WHITE OFF by RUTLAND

NOTE: This is a problem beyond Blaze King's control and is not covered under warranty.

NOTICE: COLD WEATHER OPERATION

When using any gas appliance (LPG or NAT Gas) water is a byproduct of the combustion process. Under normal conditions this moisture is expelled through the vent into the atmosphere and does not cause any harm. In extreme cold weather however the vapor may condense and freeze on any exposed surface it comes into contact with. This can cause a problem by restricting or blocking the vent, particularly with direct vent wall terminations as the exhaust is only a few inches away from the outside wall surface. What happens to the moisture after it leaves the vent cannot be controlled by the manufacturer. To extend the vent further out from the wall can sometimes but not always be an advantage. Extending the vent out from the wall can present other design problems such as ice falling from the eaves above. It is the homeowners responsibility to ensure that there is not an excessive build-up of ice on the termination.

CAUTION: WHEN OPERATING YOUR APPLIANCE DURING COLD WEATHER YOU MUST FREQUENTLY CHECK THE EXHAUST CAP FOR EXCESSIVE ICE BUILD UP.

If the appliance begins to operate abnormally—Poor flame pattern, shutting down etc, this could be an indicator of ice build up.

MAINTENANCE

CAUTION: NEVER CLEAN THE APPLIANCE WHEN IT IS HOT. ANY SAFETY SCREEN OR GUARD REMOVED FOR SERVICING MUST BE REPLACED PRIOR TO OPERATING THE APPLIANCE. DO NOT USE ANY SUBSTITUTE MATERIALS.

FREQUENCY OF SERVICE

- ◆ **Regularly:** Clean and remove any lint accumulations or debris from the grills and in any combustion and convection air passage ways.
- ◆ Keep the appliance area free from combustible materials, such as paper, wood, clothing, gasoline, flammable solids, liquids and vapors.
- ◆ Visually check the height and color of the burner and pilot flames.
- ◆ Check for unusual noise, odor and operation of the appliance.
- ◆ Check the vent terminal for any damage, or obstruction by plants or debris accumulation.
- ◆ **Once a Year:** Open the door assembly and clean the inside of the glass with a soft, non-abrasive cloth and water or a suitable, mild, non-abrasive cleaner.
- ◆ Carefully remove the logs and gently brush off any loose carbon deposits. This job is best done outside the house, wearing a dust mask. The logs are very fragile, take care not to break them. After cleaning, the logs must be replaced as per the instructions in this manual.
- ◆ **Have a qualified service technician:** Completely inspect the appliance and the venting system.
- ◆ Clean and remove any lint accumulations or debris in the firebox, on the burners, on the pilot, at the primary air opening, on the convection air blower and in any combustion and convection air passage ways.
- ◆ Check the safety system of the gas valve by lighting the unit, with the door open and blocking the flame to the thermocouple, the valve should act to shut the gas off in approximately 30 seconds.

VENTING:

1. Check the venting system for any signs of corrosion.
2. Remove the vent termination and check the inside of the vent by shining a light down the pipe.
3. Inspect pipe seams and joints and ensure they are still tight.
4. Check wall straps and all vent supports.

NOTE: The surround may be removed to gain better access to the appliance venting.

LOGS:

- ◆ Check logs are correctly positioned (see installation instructions).
- 1. Check there are no cracked logs.
- 2. Clean off any soot deposits using a soft brush.

NOTE: Incorrect log positioning may cause carbon build up and discoloration. This may void the warranty.

TECHNICAL INSTRUCTIONS

- ◆ **PILOT ASSEMBLY:** The correct flame pattern should have three strong blue flames. One flows around the thermopile, one around the thermocouple/ back tube of burner and one flows over the front burner.

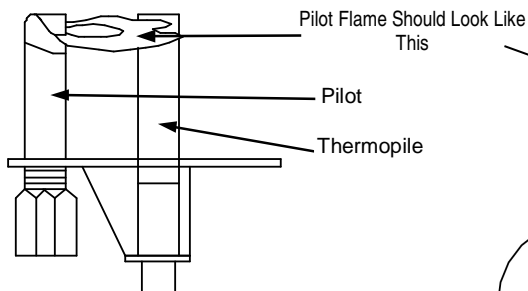

PILOT ASSEMBLY:

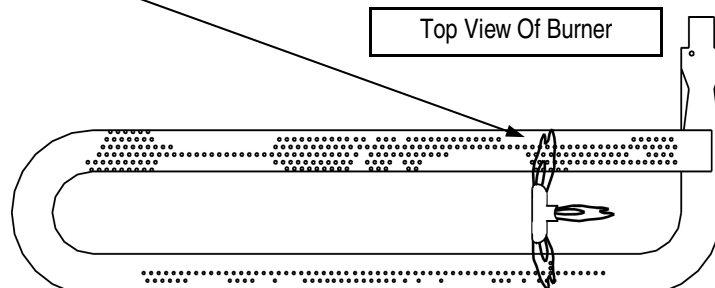

MAINTENANCE

DO NOT OPERATE APPLIANCE WITH THE GLASS DOOR REMOVED, OPEN, CRACKED, OR BROKEN. REPLACEMENT OF GLASS SHOULD BE DONE BY A LICENSED OR QUALIFIED SERVICE PERSON AS AUTHORIZED BY BLAZE KING. DO NOT ATTEMPT TO REMOVE DOOR OR REPLACE GLASS

- **USE ONLY THE GLASS DOOR CERTIFIED WITH THIS APPLIANCE**
- **Maintenance should be performed by a Qualified Service Technician.**
- **Do not use substitute materials.**
- **Do not abuse the glass door, such as striking it or slamming it shut.**
- **Do not use abrasive cleaners to clean the glass.**
- **DO NOT CLEAN GLASS WHILE DOOR IS HOT!!**

◆ **GOLD PLATING:**

1. Gold plating requires little maintenance and need only to be cleaned with a soft damp cloth. **Do not use any abrasive cleaning materials.**
2. Avoid fingerprints on gold. Wipe off fingerprints before firing.

◆ **DOOR :**

1. Check the gasket to see that it is still forming a seal. replace gasket if there is any sign of wear.
2. Check the door catches.

◆ **GLASS PANEL REPLACEMENT:**

This appliance is supplied with high temperature 5mm Ceramic glass that will easily withstand the heat your unit was designed to produce. In the event the glass breaks, have a qualified service technician replace the complete door assembly using manufactures original parts.

Wear durable work gloves to handle broken glass or removal of loose glass for disposal and safe handling prior to shipping or delivery of door / glazing frame to a qualified service center for repair.

◆ **REMOVING THE BLOWER:**

1. Turn the gas off to the unit.
2. Turn off/unplug the electric supply.
3. Remove the door of the unit.
4. Remove the log set and brick panels.
5. Remove the burner.
6. Remove the burner tray (4 screws).
7. Remove the blower access panel in the back of the firebox.
8. Pull the fan unit out far enough so you can disconnect the terminals.
9. Pull the blower assembly through the firebox through the door. Be careful you do not snag and damage the electrical connections.
10. Replacing the assembly is the reverse of the above Instructions

◆ **GAS VALVE REPLACEMENT:**

1. Disconnect electricity to the appliance.
2. Shut off the gas to the appliance and disconnect the gas line to the appliance.
3. If the appliance has a remote switch or thermostat, disconnect the wires at the front of the valve.
4. Remove the logs.
5. Remove the burner.
6. Disconnect valve wiring.
7. Undo the four screws holding the valve plate to the firebox side.
8. Gently rotate the valve to gain access to the pilot tube nut and burner supply tube nut.
9. Carefully undo the pilot and burner supply tubes and remove the valve.
10. Replacing the assembly is the reverse of the above instructions.

◆ **REMOVING THE BURNER ORIFICE**

1. Use a wrench to loosen and remove the orifice.
2. Change the orifice.

2205 - REPLACEMENT PARTS LIST

<u>PART NAME:</u>	<u>PART #</u>
Back Log	9867
Front Log	9868
Fiber Embers	0745
Gas Valve (Robert Shaw) Nat.	0718A
Gas Valve (Honeywell)	0720VC
Piezzo Push Button Igniter (R/S only)	0737
Main Burner Switch	0725
Right Twig	9869R
Left Twig	9869L
Wall Thermostat	0736
Squirrel Cage Fan	0719B
Rear Brick Panel	9865
Left Brick Panel	9866-L
Right Brick Panel	9866-R
F - 160 Fan Snapdisk	1150
Rheostat c/w Knob	Z0137A
Thermopile Generator	0721A
Electrode c/w Wire	0738B
Shroud Kit	Z2223
LPG Conversion Kit	Z0771H

APPENDIX 'A' (HIGH ALTITUDE CHART)

Equivalent Orifice Sizes at High Altitudes per the current edition of ANSI Z223.1 (Includes 4% input reduction for each 1,000 feet).

In Canada the appliance is certified for use with a number 36# (natural gas) & 53# (propane) orifice up to 4500 ft

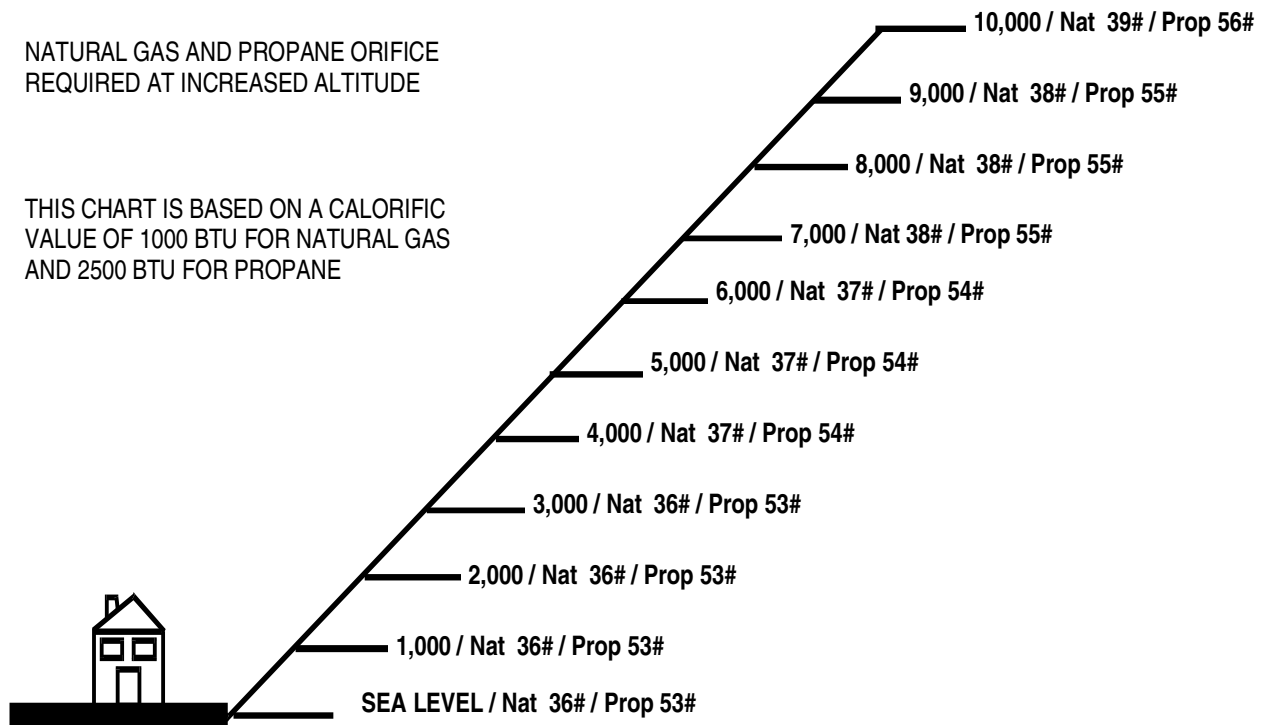

Check with your local gas supplier for correct calorific value (BTU rating).

APPENDIX 'B' (CONVERSION KITS)

" This conversion kit shall be installed by a qualified service agency in accordance with the manufacturer's instructions and all applicable codes and requirements of the authorities having jurisdiction. If the information in these instructions is not followed exactly, a fire, explosion or production of carbon monoxide may result causing property damage, personal injury or loss of life. The qualified service agency is responsible for the proper installation of the kit. The installation is not complete until the operation of the converted appliance is checked as specified in the instruction manual supplied with the kit." Before performing this or any service procedure, make sure that the gas supply to the unit and the electrical supply are shut off.

CONVERSION KIT CONTENTS

1. Main Burner orifice.
2. Pilot Orifice
3. Valve Kit.
4. Conversion Sticker

The model 2205 is designed to burn either Natural Gas or Propane (LP) Fuel. Each heater leaves the factory equipped for one specific fuel but it is a simple operation to convert the heater to an alternate fuel in the field. The original fuel type is marked on the rating label:

To convert to an alternate fuel, follow these steps:

1. Open the front viewing door.
2. Remove the log set and brick panels.
3. Remove the log support plate screws.
4. Remove the burner assembly.
5. Using a 1/2" socket, unscrew the main burner orifice and replace with alternate gas orifice.

NATURAL GAS PROPANE

6. Carefully unscrew the pilot assembly (2 screws) and remove the pilot orifice and replace with alternate pilot orifice.
7. Convert the gas valve. See the separate gas valve manufacturers instructions supplied in the kit.
8. Fill out conversion sticker supplied in conversion kit.



LEAK TESTING:

CAUTION: DO NOT TEST FOR LEAKS WITH AN OPEN FLAME.

- ◆ With the main burner "ON", test the new pressure regulator using a soap solution
- ◆ Check all fittings for leaks using the soap solution.

FUEL CONVERSION LABEL:

- ◆ Fill out and attach the fuel conversion label provided in the kit.

AERATION ADJUSTMENT

IMPORTANT: YOU CHANGED THE FUEL WHICH MEANS THE AERATION WILL REQUIRE ADJUSTMENT

See page 14 for instructions on adjusting the aeration.

ALLOW THE UNIT TO BURN FOR AT LEAST 15 MINUTES TO CHECK THE FLAME PICTURE.

- ◆ If you have converted from Natural gas to Propane you will have to INCREASE the aeration opening as propane requires more primary air to burn correctly.
- ◆ If you have changed from Propane to Natural gas you may have to REDUCE the aeration opening as Natural gas requires less primary air to burn correctly.

BLAZE KING WARRANTY

Gas stoves manufactured by Blaze King Industries and/or Valley Comfort Systems Inc. are covered by a limited lifetime warranty against manufacturers defects in material and workmanship. Details of this comprehensive warranty program are outlined below. In addition to the terms outlined for the limited lifetime warranty, our products carry a 5 year warranty which covers mechanical and electrical components including labor costs outlined below. The combination of these warranty policies provide a very strong coverage package that we are proud to offer you, our customers. Our Blaze King tradition of building high quality products for over 25 years is really your most important assurance of quality but it's comforting to know that should something fail (and it occasionally does) you are covered by a warranty policy that leads the industry. To ensure coverage you must have your unit properly installed by an authorized Blaze King dealer and you must register your ownership. Blaze King's warranty policy applies only to units sold in the USA or Canada. No person is authorized to modify this warranty or make any additional warranties on behalf of the manufacturer, Blaze King.

Components and parts 5 year warranty:

Blaze King warrants the following parts; blower motors, door gasket, blower speed control, logs, pilot assembly, gas valve, gas lines, thermocouple and/or thermopile against defects in material or workmanship to the original purchaser, for five years following the date of purchase.

Labor costs during the 5 year warranty period:

Blaze King manufacturers warranty covers labor costs to the original purchaser based on our schedule of approved charges, provided to our authorized dealers. Blaze King will only be responsible for labor costs provided by our authorized dealers and based upon the schedule.

Limited Lifetime Coverage

This warranty contains different terms that cover specific parts of the gas appliance. Blaze King warrants the following parts of the gas appliance against defects in material or workmanship to the original retail purchaser. For the first five years of ownership, the combustion chamber, heat exchanger and burners will be replaced by Blaze King, conditional upon production availability. From year 6 through to the end of ownership by the original purchaser, Blaze King will provide replacement or repair of the aforementioned parts, conditional upon current production availability, at 50% of current retail price but does not cover any charges relating to labor. This portion of the warranty coverage is not transferable and applies only to the original purchaser.

How to Get Service

If this product requires repair or replacement due to defects in material or craftsmanship during the first five years of ownership, contact your Blaze King dealer and explain the nature of the problem. If the dealer is unable to repair or replace the product to your satisfaction then contact Blaze King at 509-522-2730 in the USA or 250-493-7444 in Canada. If a replacement part is sent directly to you, please contact Blaze King to obtain a **Return Authorization Number (RA#)** for all defective parts. Blaze King will refuse delivery of any returned packages not clearly showing an (RA#). All expenses relating to the shipping of defective parts or entire stoves will be at purchaser's expense.

Legal Rights of Purchaser:

This warranty gives you specific legal rights and you may have other rights that vary from state to state (or province to province).

Blaze King Assurance:

Included with each gas stove manufactured by Blaze King is a Warranty Card, which must be completed in its entirety and returned to Blaze King within ten days from the date of purchase. Blaze King will be unable to properly administer the warranty if the card is not completed and registered on file.

This Warranty will pay to repair and or replace parts which fail under normal usage at labor rates established by this Agreement. Extra charges such as mileage, overtime or shipping are not covered. Nuisance calls are not covered by this Warranty. This Warranty is for residential stoves and does not apply to commercial applications. Only failure attributed to normal usage of the electronic and mechanical functions of the stove are covered. Failure due but not limited to, abuse, negligence, impact, fire, lightning, power failures and or surges, rust and corrosion are not covered. Damage and or repairs to cabinets and all exterior components, remote controls, and normal maintenance, related duct work, power surges, electrical spikes or electrical circuit overloads, filters, knobs, glass, gaskets, block and tile etc., are not covered. Additional or unusual utility bills incurred due to any malfunction or defect in equipment listed on this Warranty are not covered. Labor cost of gaining access to or removal of a unit that requires special equipment or tools such as cranes, ladder trucks, etc., are not covered. This Warranty does not include, cleaning, adjustments of the customer controls, customer product education or any other regular service/maintenance functions. Labor, materials, expenses or equipment required to comply with the law and or regulations set forth by any governmental agencies are not covered by this Plan.

BLAZE KING LIMITED LIFETIME WARRANTY

Blaze Kings Responsibilities:

If the purchaser has complied with all the terms and conditions of this warranty and if the purchaser has notified Blaze King of the defect prior to the expiration of any warranted items, the following procedure will occur. Blaze King will inspect the product to determine that there is indeed a defect and that the defect is covered by warranty. Blaze King will either repair or replace the product at its' discretion. Under no condition whatsoever does Blaze King provide or imply warranty coverage for venting components used in the installation of our products. This warranty details the obligations and liabilities of Blaze King and no other warranties are expressed or implied. Blaze King reserves the right to investigate and settle all claims against warranted parts at their discretion. In no event shall Blaze King be held responsible for indirect or consequential damages of any nature which are in excess of the original purchase price of the product. Blaze King may at its' discretion discharge any or all obligations by refunding the wholesale price of any defective part or parts.

Misuse of Stove Nullifies Warranty:

The above warranty is conditional upon the proper installation and use of the product according to the manufacturers instructions as specified in the "**Owners Installation & Operations Instructions**" and in compliance with applicable local building and fire codes. Blaze King recommends the local building inspector or fire department inspect the unit prior to initial use. Consult the "Owners Installation & Operations Instructions" supplied with each unit prior to installation or operation. Alteration, abuse, lack of maintenance, faulty repairs or misuse will void the warranty. Abuse includes but is not limited to the use of fuels other than as specified in the "Owners Installation & Operations Instructions."

APPENDIX 'D' (TROUBLE SHOOTING)

Please check to make sure the instructions are followed exactly before attempting trouble shooting of the appliance.

WARNING: Trouble shooting and servicing of gas and electrical devices of the appliance should only be conducted by a qualified service technician.

CAUTION: Label all wires prior to disconnection when servicing controls. Wiring errors can cause improper and dangerous operation. Verify proper operation after servicing.

PROBLEM	POSSIBLE CAUSE	CORRECTIVE ACTION
Pilot will not light after pressing the sparker many times.	<i>Air in gas line. No gas supply. Piezo wire loose. Defective Piezo. Piezo wire grounding. Electrode grounding. Electrode gap Incorrect.</i>	<p>⇒ Purge air out of gas line.</p> <p>⇒ Check to make sure the gas supply to the appliance is turned on and there is adequate gas supply pressure to the appliance.</p> <p>⇒ Check for sparks between the spark electrode and the pilot head when the sparker is pressed. If there are no sparks:</p> <p>⇒ Check for broken or poor connection from the sparker to the electrode.</p> <ul style="list-style-type: none"> • Check for the spark shorting or arcing at other locations. • Check for defective piezo. • Check for defective/cracked spark electrode. <p>⇒ With the door removed, try lighting the pilot with a match.</p> <p>⇒ Note: If there is no gas or air coming out of the pilot and there is gas pressure to the appliance, the pilot orifice may be blocked or the gas valve maybe defective.</p>
Pilot will not remain on after being lit.	<i>Poor Pilot flame. Faulty thermopile. Faulty thermocouple. Thermocouple and/or Thermopile grounding. Loose TP-THTP on gas valve. Gold contact switch Faulty gas valve. Note: This is very rare and faults blamed on the gas valve are usually incorrect.</i>	<p>⇒ Check to see if the pilot flame is large enough to reach and surround the thermocouple. If the flame is too small, check for correct gas supply pressure. If pressure is good, adjust the pilot flame size with the adjustment screw on the valve. If the flame cannot be adjusted, there might be some debris obstructing the pilot orifice.</p> <p>⇒ Check for correct millivolts at the thermopile. The thermopile should generate at least 250 mV.</p> <p>⇒ Check for correct millivolts at the thermocouple. The thermocouple should generate at least 30 mV.</p> <p>⇒ Check for poor connection of the thermocouple and thermopile to the valve.</p> <p>⇒ If readings are correct for thermopile and thermocouple replace gas valve.</p>
The main burner does not turn on with the pilot lit.	<i>Gas valve not in on position. Faulty thermopile. Faulty wall or unit on/off switch. Faulty thermostat.</i>	<p>⇒ Check to make sure the control knob is turned to the 'ON' position.</p> <p>⇒ Test thermopile and check pilot (see above).</p> <p>⇒ Place jumper wire across terminals TH-THTP, if burner comes on this will indicate you have a poor connection or faulty appliance on/off switch, wall switch or wall thermostat.</p>

