

Blaze King

CLARITY CL2714.IPI

**DIRECT VENT GAS FIREPLACE INSERT
with Intermittent Pilot Ignition (IPI)**

For use with Natural Gas (NG) or Propane (LPG)

OPERATION & INSTALLATION MANUAL



Blaze King recommends that its gas hearth products be installed and serviced by professionals who are certified in the U.S. by the National Fireplace Institute (NFI) as NFI Gas Specialists.



PFS REPORT: #F18-431

**Installer: Please COMPLETE THE DETAILS ON THE LAST PAGE
and leave this manual with the homeowner.**

Homeowner: Please SAVE THESE INSTRUCTIONS for future reference.

MANUFACTURED BY

Valley Comfort Systems Inc., 1290 Commercial Way, Penticton BC, Canada, V2A 3H5
web: www.blazeking.com email: info@blazeking.com

ATTENTION: The authority having jurisdiction (municipal building department, fire department, etc.) should be consulted before installation to determine the need to obtain a permit.

Pour la version française de nos manuels S.V.P. vous référez à notre site web: www.blazeking.com

⚠ WARNING

FIRE OR EXPLOSION HAZARD
Failure to follow safety warnings exactly could result in serious injury, death, or property damage.

- Do not store or use gasoline or other flammable vapors and liquids in the vicinity of this or any other appliance.

WHAT TO DO IF YOU SMELL GAS

- Do not try to light any appliance.
- Do not touch any electrical switch; do not use any phone in your building.
- Leave the premises.
- Immediately call your gas supplier from a neighbor's phone. Follow the gas supplier's instructions.
- If you cannot reach your gas supplier, call the fire department.

- Installation and service must be performed by a qualified installer, service agency or the gas supplier.

This appliance may be installed in an aftermarket, permanently located, manufactured (mobile) home, where not prohibited by local codes.

This appliance is only for use with the type of gas indicated on the rating plate. This appliance is not convertible for use with other gases, unless a certified kit is used.

A barrier designed to reduce the risk of burns from the hot viewing glass is provided with this appliance and shall be installed for the protection of children and other at-risk individuals. If the barrier becomes damaged, the barrier shall be replaced with the manufacturer's barrier for this appliance.

⚠ WARNING



HOT GLASS WILL CAUSE BURNS.
DO NOT TOUCH GLASS UNTIL COOLED.
NEVER ALLOW CHILDREN TO TOUCH GLASS.

The content within this manual describes the installation and operation of the Blaze King Clarity CL2714. It is against federal regulations to operate this appliance in a manner inconsistent with the operating instructions in this manual. Blaze King grants no warranty, implied or stated, for the installation and maintenance of this appliance and assumes no responsibility of any consequential damage(s).

<i>TEST CERTIFICATION DATA</i>		
	Natural Gas (NG)	Propane (LPG)
Steady State Efficiency (High / Effy _{SS,H})	66.87%	69.48%
Fireplace Efficiency (P4 / FE)	63.82%	64.63%

This appliance is tested and certified to the following US and Canadian gas appliance standards:

- ANSI Z21.88-2017 / CSA 2.33-2017 - Vented Gas Fireplace Heaters
- CSA 2.17-2017 - Gas-Fired Appliance for Use at High Altitudes
- CSA P.4.1-15 - Testing Method for Measuring Annual Fireplace Efficiency

This appliance must be installed by a qualified gas installer. The installation must conform to local codes or, in the absence of local codes, with the National Fuel Gas Code, ANSI Z223.1 / NFPA 54 in the US, or the Natural Gas and Propane Installation Code, CSA B149.1 in Canada. This appliance is certified for installation in a bedroom or a bedsitting room and may be installed in an aftermarket, permanently located, manufactured (mobile) home where not prohibited by local codes. This appliance is certified for direct vent discharge only. This appliance must be vented using the listed and approved vent components described in this manual.

WARNING

IF THIS APPLIANCE IS NOT PROPERLY INSTALLED OR OPERATED, A HOUSE FIRE MAY RESULT LEADING TO SERIOUS BODILY HARM AND EVEN DEATH. TO REDUCE THE RISK OF FIRE, PLEASE READ THIS ENTIRE MANUAL BEFORE INSTALLING AND OPERATING THIS APPLIANCE. CONTACT LOCAL BUILDING OR FIRE OFFICIALS ABOUT RESTRICTIONS AND INSTALLATION INSPECTION REQUIREMENTS IN YOUR AREA.

DO NOT OPERATE THIS APPLIANCE WITHOUT FULLY ASSEMBLING ALL COMPONENTS. DO NOT INSTALL DAMAGED, INCOMPLETE, OR SUBSTITUTE COMPONENTS. FAILURE TO POSITION COMPONENTS IN ACCORDANCE WITH THE DIAGRAMS IN THIS BOOKLET OR FAILURE TO USE COMPONENTS SPECIFICALLY APPROVED WITH THIS APPLIANCE MAY RESULT IN PROPERTY DAMAGE OR PERSONAL INJURY.

SAVE THESE INSTRUCTIONS FOR FUTURE REFERENCE.



CALIFORNIA PROPOSITION 65

WARNING: This product can expose you to chemicals including benzene, which is known to the State of California to cause cancer and birth defects or other reproductive harm. For more information:

www.P65Warnings.ca.gov

SPECIFICATIONS	5
APPLIANCE DIMENSIONS	6
SAFETY CLEARANCES	8
SAFETY PRECAUTIONS	10
VENTING	11
OPTIMAL VENTING PERFORMANCE.....	11
VENTING CONFIGURATIONS	11
TERMINATION ABOVE ROOF.....	11
EXTERIOR WALL PASS THROUGH	11
VENT TERMINATION LOCATION.....	11
VENT TERMINATION RESTRICTIONS.....	12
INSTALLATION	13
GAS CONNECTIONS	13
ELECTRICAL REQUIREMENTS.....	13
BATTERY HOLDER.....	13
HIGH ALTITUDE INSTALLATION.....	13
FIREPLACE MODIFICATIONS	14
INITIAL SETUP	15
VENT CONNECTOR	16
MOBILE HOME INSTALLATION	17
VENT RESTRICTOR	17
AIR SHUTTER ADJUSTMENT	18
PROFLAME 2 WIRING DIAGRAM	19
PROFLAME VALVE SCHEMATIC	20
FUEL CONVERSION	21
LIGHTING INSTRUCTIONS	24
REMOTE OPERATION	25
MAINTENANCE and SERVICE	30
ROUTINE MAINTENANCE.....	30
CLEANING SURFACES.....	30
CLEANING DOOR GLASS.....	30
DOOR GLASS REPLACEMENT.....	30
SAFETY SCREEN REPLACEMENT.....	30
VENTING COMPONENTS	31
PARTS LIST	34
TROUBLE SHOOTING	35
WARRANTY	38
NOTES	42

CLARITY 2714 IPI, CL2714.IPI SPECIFICATIONS		
Flue Vent Size	3" x 3" Co-Linear	
Electrical Rating	120 V.A.C.	
Shipping Weight	200 lbs (90.7 kg)	
	<i>Natural Gas (NG)</i>	<i>Propane (LPG)</i>
Manifold Pressure	3.8" w.c. (0.95 kPa)	11.0" w.c. (2.74 kPa)
Minimum Supply Pressure for Purpose of Input Adjustment	7.0" w.c. (1.74 kPa)	13.0" w.c. (3.23 kPa)
Orifice Size	DMS #41	DMS #53
Nominal Input Rating	24,682 BTU/hr	24,956 BTU/hr
Minimum Input Rating	12,893 BTU/hr	12,982 BTU/hr
Primary Air Opening	50% (Minimum)	Open

PARTS INCLUDED

1. Manual Kit (w/ Manual, Warranty Cards, Remote, and Batteries)

REQUIRED KIT (MUST INSTALL ONE OPTION)

- | | |
|---|---------------------------------|
| 1. S.Z4981 - Shroud 24.5" x 36.5" | 2. S.Z4982 - Shroud 26.5" x 38" |
| 3. S.Z4983 - Shroud 29" x 40" | 4. S.Z4984 - Shroud 32" x 44" |
| 5. S.Z4985 - Shroud 32" x 44" Trimmable | |

OPTIONAL ACCESSORIES

- | | |
|---|---|
| 1. S.ZPFC - Smart Home Kit | 2. S.0402 - Glass Kit 3 Piece |
| 3. S.0519 - Log Set 5 Piece River Washed | 4. S.0529 - Log Set 7 Piece River Washed |
| 5. S.0529.T - Log Set 7 Piece Traditional | 6. S.0602 - Glass Kit 4 Piece |
| 7. S.Z0767 - LP Conversion Kit | 8. S.Z0771 - NG Conversion Kit |
| 9. S.Z4990 - 45" Shroud Shelf w/ Risers | 10. S.Z4991 - Mantel Shield 40" Clearance |
| 11. S.Z4992 - Mantel Shield 32"-34" Clearance | 12. S.Z4993 - Under Mantel Shield 35" Clearance |
| 13. S.Z4994 - Angled Raised Shroud Base | 14. S.Z5277.IPI - Fan Kit |

APPLIANCE DIMENSIONS

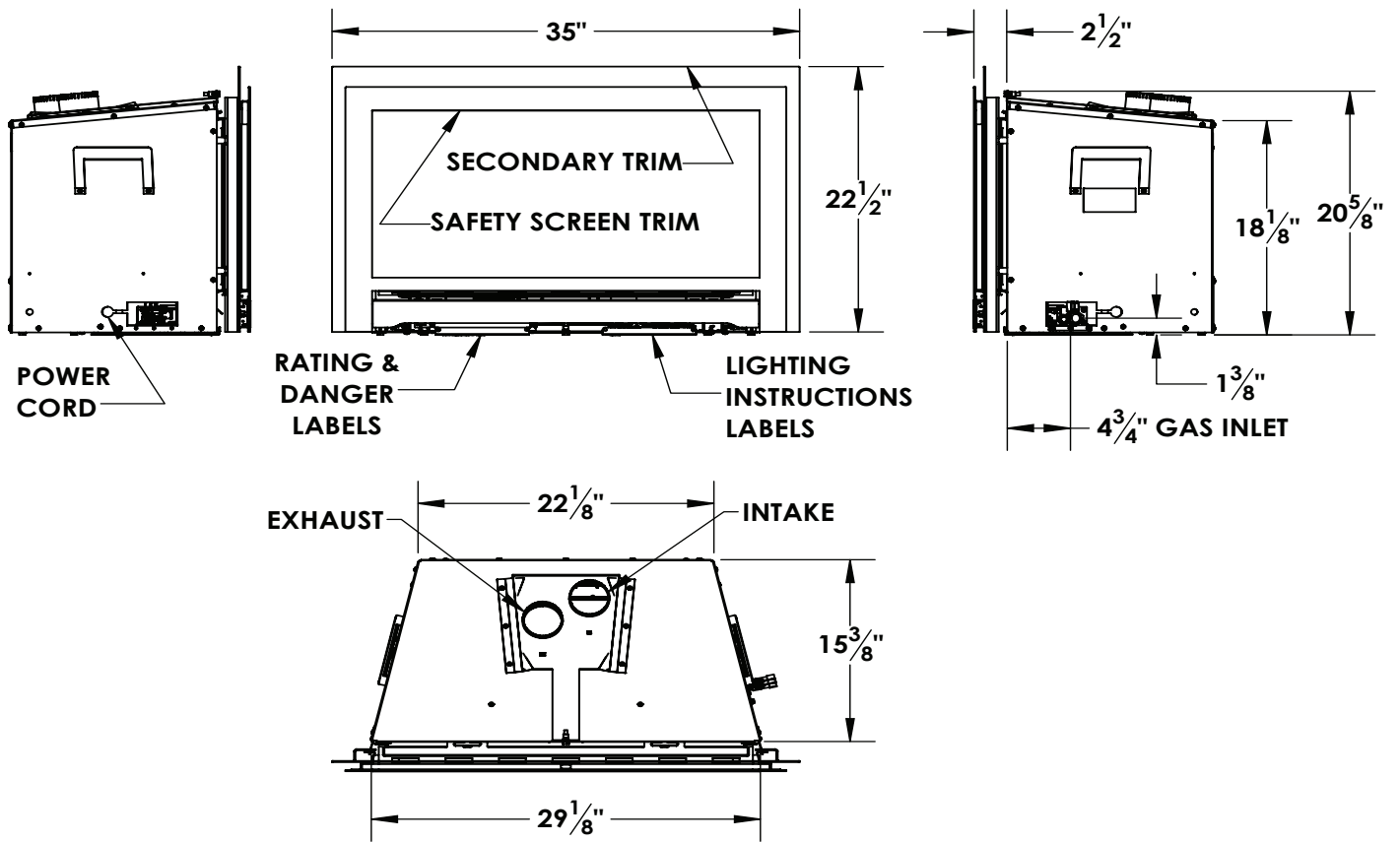

<p><i>S.Z4981 - SHROUD 24.5" x 36.5"</i></p>	
<p><i>S.Z4982 - SHROUD 26.5" X 38"</i></p>	

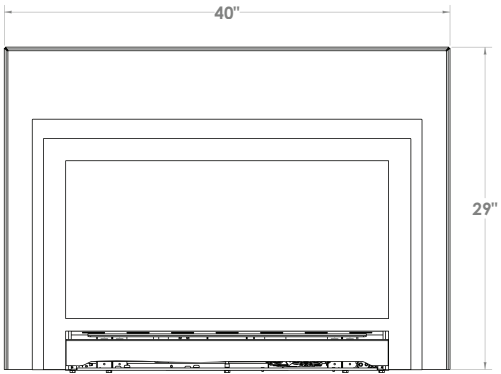
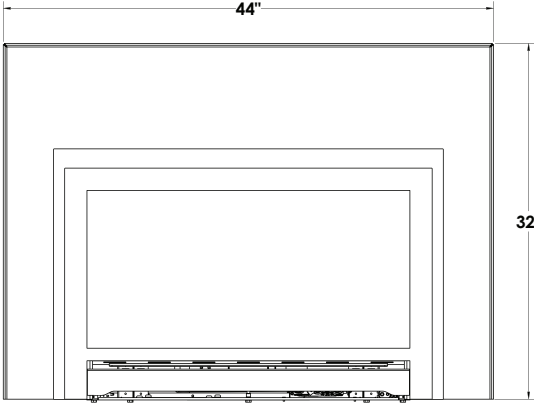
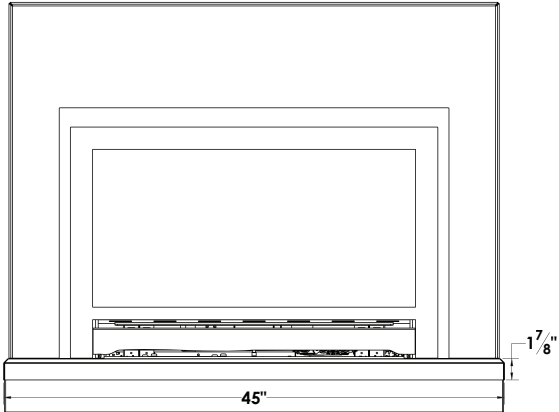
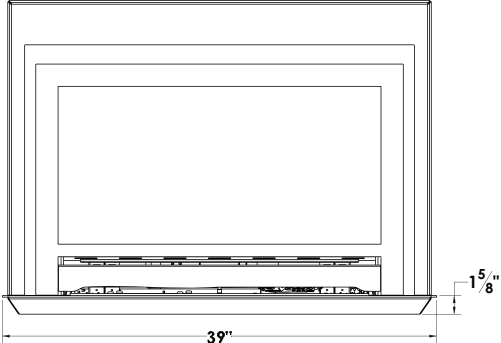
<p><i>S.Z4983 - SHROUD 29" x 40"</i></p>	
<p><i>S.Z4984 - SHROUD 32" x 44"</i></p>	
<p><i>S.Z4990 - 45" SHELF WITH RISERS</i> <i>*CAN BE INSTALLED WITH ANY SHROUD OPTION</i></p>	
<p><i>S.Z4994 - ANGLED SHROUD BASE</i> <i>**CAN ONLY BE INSTALLED WITH: S.Z4981 OR S.Z4982</i></p>	

MINIMUM CLEARANCES TO COMBUSTIBLES		
A	Appliance to sidewall.	4.5" (115 mm)
B	- Bottom of appliance to underside of mantel (Fig. 1)	48" (1219 mm)
	- With S.Z4991 Mantel Shield kit (Fig. 2)	40" (1016 mm)
	- With S.Z4993 Under Mantel Shield kit (Fig. 3)	35" (889 mm)
	- With S.Z4992 Mantel Shield kit (Fig. 4)	34" (864 mm)
	- With S.Z4992 Mantel Shield kit (Fig. 4)	32" (813 mm)
C	Maximum mantel depth.	12" (305 mm)
D	Minimum ceiling clearance from bottom of appliance.	67.5" (1715 mm)

NOTE: CHECK LOCAL CODES FOR FLOOR REQUIREMENTS. THIS APPLIANCE IS SUITABLE ONLY FOR INSTALLATION IN A MASONRY OR FACTORY BUILT FIREPLACE.

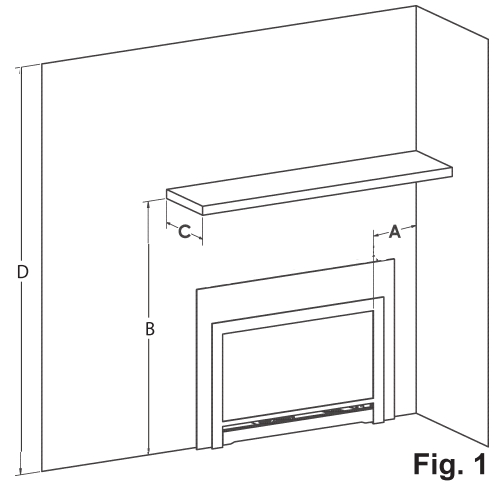
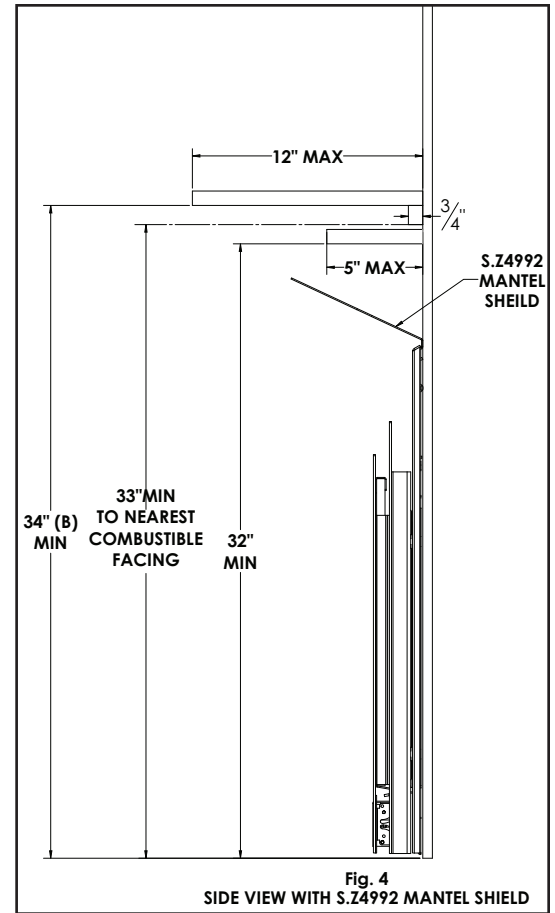
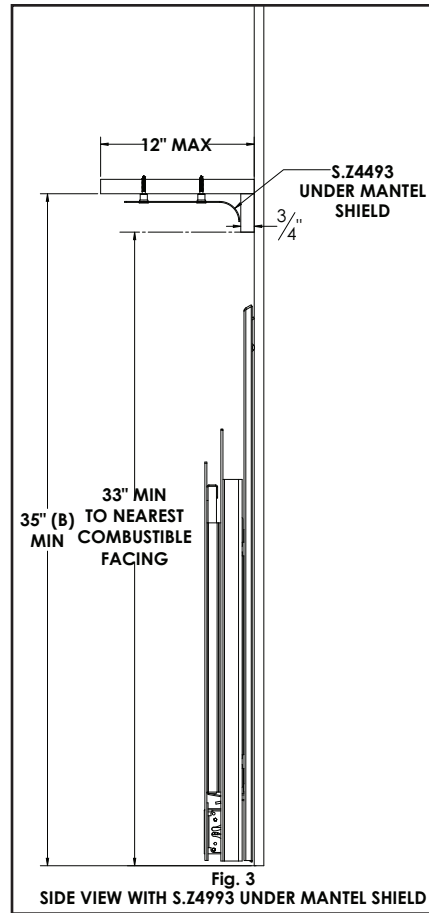
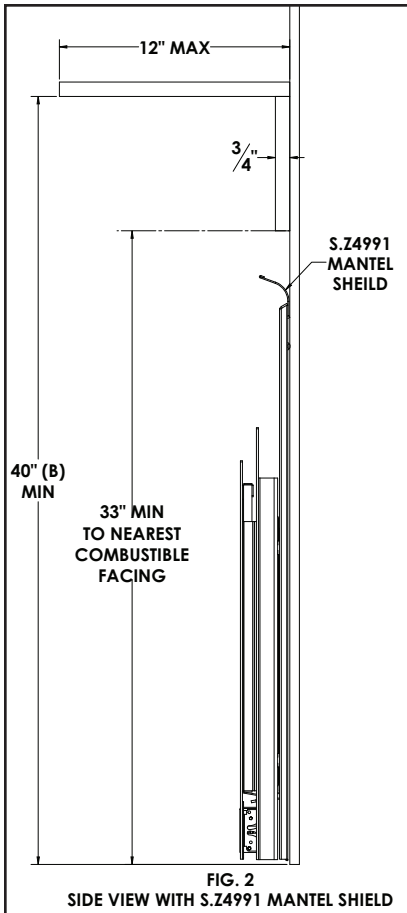

Fig. 1



MINIMUM FIREPLACE DIMENSIONS

Refer to the diagrams below for the minimum fireplace dimensions required to properly install this appliance:

THE LEVELLING BOLTS AT THE BASE OF THE APPLIANCE CAN BE ADJUSTED IF THE COMBUSTIBLE FLOOR IN FRONT OF THE APPLIANCE IS NOT LEVEL WITH THE HEARTH.

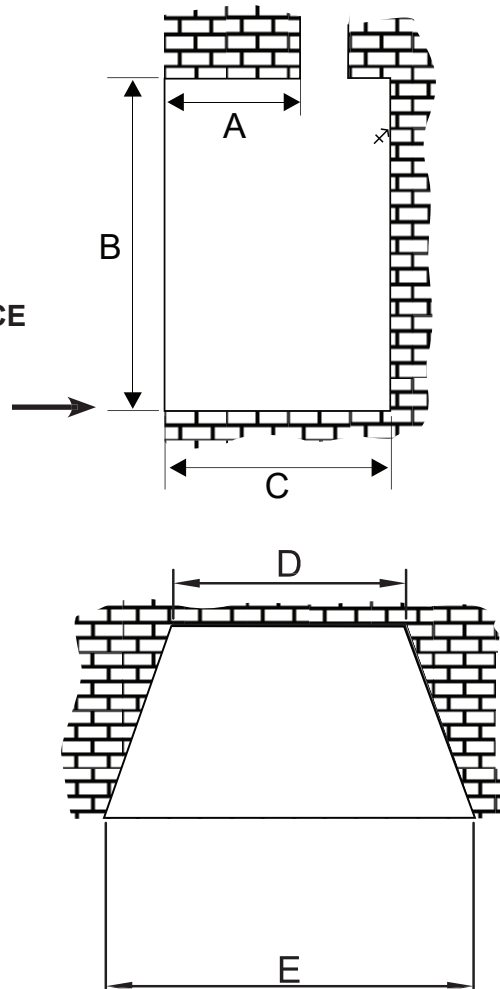

Max Lintel Bar Depth	A	9 1/4" 235 mm
Min Height	B	20 3/4" 527 mm
Min Depth	C	15 5/8" 397 mm
Min Width (rear)	D	22" 559 mm
Min Width (front)	E	30" 762 mm

⚠️ WARNING

FIRE OR EXPLOSION HAZARD. FAILURE TO FOLLOW SAFETY WARNINGS EXACTLY COULD RESULT IN PROPERTY DAMAGE, SERIOUS BODILY HARM, OR DEATH.

YOUR SAFETY

- To prevent injury, do not allow anyone who is unfamiliar with the appliance to operate it.
- The appliance should be inspected before initial use and, at least, annually by a qualified service person.
- It is imperative the control compartments, burners, and circulating airways of the appliance be kept clean. More frequent cleaning may be required due to excessive lint from carpeting, bedding material, etc.
- Always connect this gas appliance to a vent system and vent to the outside of the building envelope. Do not vent to another room or inside the building. Do not connect to a chimney flue serving a separate solid-fuel burning appliance. Ensure the specified vent pipe is used, properly sized, and of adequate height to provide sufficient draft. The flow of combustion and ventilation air must not be obstructed.
- Have the venting system inspected annually by a qualified installer for blockage and signs of deterioration.
- If this appliance is pulled out of its installation and/or the vent-air intake pipes are disconnected for any reason, ensure that the vent-air intake pipes are reconnected and re-sealed in accordance to the instructions noted in the “*INSTALLATION*” section.
- Due to high temperatures, this appliance should be located out of high traffic areas and away from furniture and draperies.
- Young children should be carefully supervised when in the same room as the appliance. Toddlers, young children, and others may be susceptible to accidental contact burns. A physical barrier is required if there are at risk individuals in the house. To restrict access to the appliance, install an adjustable safety gate to keep toddlers, young children, and other at risk individuals out of the room and away from hot surfaces. Any safety screen, guard, or barrier removed for servicing the appliance must be replaced prior to operating the appliance.
- Clothing or other flammable materials should not be placed on or near the appliance. This appliance should not be used as a drying rack for clothing or for hanging Christmas stockings/decorations.
- Do not store or use gasoline or other flammable vapors and liquids in the vicinity of this appliance.
- Due to the paint curing, a faint odor and slight smoking will likely be noticed when the appliance is first used. Open a window until the smoking stops.
- To prevent injury, if the pilot or pilot and burners have gone out on their own, open the glass door and wait 5 minutes to air out before attempting to relight the appliance.
- Do not use this appliance if any part has been under water. Immediately contact a qualified service technician to inspect the appliance and to replace any part of the control system and any gas control which has been under water.
- Do not abuse the glass by striking it or slamming the door shut.

OPTIMAL VENTING PERFORMANCE

For best venting performance, follow these guidelines:

1. This appliance must be vented using the following listed and approved vent components: Selkirk (Direct-Temp), Amerivent, M&G Duravent, BDM, Olympia, and ICC. Read the manufacturer's installation instructions before installing the venting system.
2. Venting must be installed in a location free of plumbing, electrical wiring, and heating or air conditioning ducts.
3. Terminate the vent with only a termination certified for use with this appliance.
4. Ensure proper resealing of the vent air intake system when venting is installed, inspected, or replaced.
5. Observe minimum and maximum vent height and length restrictions stated in this manual.
6. Observe all local code restrictions, if any, regarding the installation of this type of gas appliance.

VENTING CONFIGURATIONS

Typical Installation

- 8' (2.44 m) minimum vertical vent on top of the appliance.

Horizontal Termination

- One 90° bend and maximum 2' (610 mm) horizontal run to horizontal termination (minimum 8' vertical vent)

Other installations

- The maximum total vertical height is 36' (10.97 m) (**subject to local codes**).
- Use vent restrictor on vents from 20' (6.09 m) to 36' (10.97 m) to obtain optimal flame appearance, see "**VENT RESTRICTOR**" and "**BURNER FLAME APPEARANCE**"

TERMINATION ABOVE ROOF

The vent must be a minimum 2' (610 mm) from any wall. Install flashing with the upper portion slid under the roofing material and the lower portion over the roofing material. Consult local codes for minimum vent cap height above the roof.

Note: Do not fully fasten until final adjustments have been made.

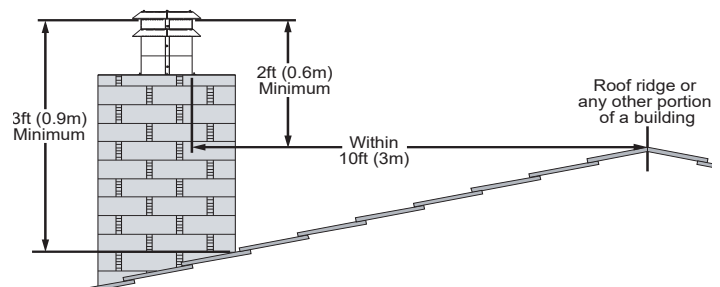

EXTERIOR WALL PASS THROUGH

When installing a termination onto vinyl siding, a vinyl siding kit must be used. This prevents the termination from being recessed into the siding. Apply a bead of non-hardening mastic to form a seal between the standoff and the termination cap. Attach the termination cap to the exterior wall by inserting four wood screws through the holes in the corners of the vent termination. Complete the installation by applying a bead of mastic around the outer edge of the vinyl standoff. With the termination cap installed, you can now connect the vent pipe by sliding the appliance back towards the wall and carefully inserting the vent pipe into the terminal. Before the final connection is made, slide on the decorative wall thimble. Secure the termination cap by fastening the termination straps to the pipe as close to the exterior wall as possible using sheet metal screws. Ensure that the straps are hidden by the wall thimble cover. Apply decorative trim if required.

VENT TERMINATION LOCATION

- In heavy snowfall areas make sure the vent termination is located where it will not be blocked by snowfall or snow from snow removal equipment.
- Locate the vent termination away from plants, bushes, or any other object on or near the vent termination that will interfere or obstruct the air flow around it.
- Do not recess vent termination into walls, sidings, or planters.
- Vent terminations located below 7 ft (2130 mm) from grade level or anywhere that it is a burn hazard to the public, such as patios and balconies, must be protected with an approved termination cage.

VENT TERMINATION RESTRICTIONS

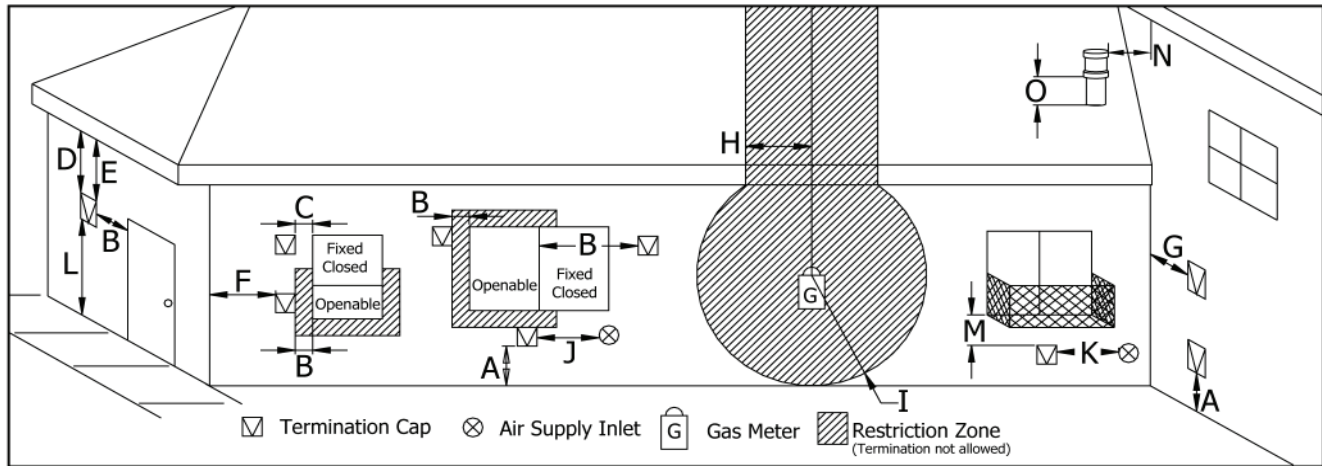

TABLE 1 - VENT TERMINATION CLEARANCES

Letter	Canadian Installation ¹	US Installation ²	Description
A	12 in (30 cm)		Clearance above grade, verandah, porch, deck, or balcony.
B	12 in (30 cm)	9 in (23 cm)	Clearance from window or door that may be opened.
C	12 in (30 cm)*		Clearance from permanently closed window (to prevent condensation).
D	24 in (60 cm)*		Vertical clearance to ventilated soffit located above the terminal, within a horizontal distance of 2 ft (60 cm) from center line of terminal.
E	12 in (30.5 cm) to 24" (61 cm)		Clearance to unventilated soffit.
F	12 in (30 cm)*		Clearance to outside corner.
G	12 in (30 cm)*		Clearance to inside corner.
H	3 ft (91 cm) within a height of 15 ft (4.5 m) above the meter/regulator assembly	3 ft (91 cm) within a height of 15 ft (4.5 m) above the meter/regulator assembly*	Clearance to each side of center line extended above meter/regulator assembly.
I	3 ft (91 cm)	3 ft (91 cm)*	Radial clearance around service regulator vent outlet.
J	12 in (30 cm)	9 in (23 cm)	Clearance to non-mechanical air supply inlet to building, or the combustion air inlet to any other appliance.
K	6 ft (1.83 m)	3 ft (91 cm) above if within 10 ft (3 m) horizontally	Clearance to mechanical air supply inlet.
L	7 ft (2.13 m) ^t	7 ft (2.13 m) ^{*t}	Clearance above paved sidewalk or paved driveway located on public property.
M	12 in / 30 cm ⁺	12 in / 30 cm ^{*+}	Clearance under verandah, porch, deck, or balcony.
N	12 in (30 cm)*		Clearance horizontally to any surface (such as an exterior wall) for vertical terminations.
O	12 in (30 cm)		Clearance above roof line for vertical terminations.

¹ In accordance with the current CSA B149, Natural Gas and Propane Installation Code.

² In accordance with the current ANSI Z223.1 NFPA 54, National Fuel Gas Code.

* These numbers are only estimates.

^t A vent shall not terminate directly above a side walk or paved driveway that is located between two single family dwellings and it serves both dwellings.

⁺ Permitted only if verandah, porch, deck, or balcony is fully open on a minimum of two sides beneath the floor.

Clearances are in accordance with local installation codes and the requirements of the gas supplier.

NOTE: Venting terminals shall not be recessed into walls or siding.

NOTE: THIS SECTION OF THE MANUAL IS FOR THE USE OF QUALIFIED SERVICE PERSONS ONLY.

GAS CONNECTIONS

Have a qualified gas fitter run a gas supply line to the appliance. The line must be properly sized and fitted according to the installation codes. This appliance is equipped with a manual shutoff ball valve with a 1/2" female pipe thread outlet. If the fireplace size restricts connection at the factory shutoff ball valve location, relocate the shutoff ball valve within the cavity beneath the firebox. Check for proper gas supply pressure:

- Use a small, flat tip screw driver to loosen the set screw on supply pressure tap on the gas valve (refer to "**PROFLAME VALVE SCHEMATIC**" for pressure tap location).
- Once loose, place a test gauge on the tap.
- The minimum supply pressure is 7.0" w.c. (1.24 kPa) for natural gas and 11.0" w.c. (3.0 kPa) for propane.
- The maximum supply pressure should never exceed 14.0" w.c. (3.48 kPa) or 0.5 psi for both natural gas and propane.
- **When finished testing, be sure to retighten the pressure tap set screw.**

Before connecting the appliance to the gas supply line, double check that the appliance is indeed designed for the gas type you are using. The gas type markings are located on the appliance rating label as well as on the appliance's gas valve. Adequate clearance for proper installation and checking of the gas connections must be provided. All gas connections must be checked for gas leaks before appliance operation.

⚠ WARNING

THIS APPLIANCE AND ITS MANUAL SHUTOFF VALVE MUST BE DISCONNECTED FROM THE GAS SUPPLY PIPING SYSTEM DURING ANY PRESSURE TESTING WHERE TEST PRESSURES EXCEED 1/2 psi (3.5 kPa).

THE APPLIANCE MUST BE ISOLATED FROM THE GAS SUPPLY PIPING SYSTEM BY CLOSING ITS MANUAL SHUTOFF VALVE DURING ANY PRESSURE TESTING WHERE TEST PRESSURES ARE EQUAL TO OR LESS THAN 1/2 psi (3.5 kPa).

FAILURE TO COMPLY WILL DAMAGE THE APPLIANCE'S GAS VALVE AND VOID MANUFACTURER'S WARRANTY.

ELECTRICAL REQUIREMENTS

This appliance must be electrically grounded in accordance with local codes or, in the absence of local codes, with the National Electrical Code ANSI / NFPA 70 in the U.S. or the Canadian Electrical Code CSA C22.1 in Canada. This appliance is equipped with a three prong grounding plug for protection against shock hazard and should be plugged directly into a properly grounded three pronged receptacle. Do not cut or remove the grounding prong from this plug. **Label all wires prior to disconnection when servicing controls. Wiring errors can cause improper and dangerous operation. Verify proper operation after servicing.**

BATTERY HOLDER

There are four AA batteries supplied with the appliance that must be installed into the battery holder located to the left of the IFC module in the lower cavity of the appliance. The life span of the batteries depends on various factors: quality of batteries used, the number of ignitions of the appliance, the number of changes to the room thermostat set point, etc. It is recommended that the batteries be checked/replaced once a year.

HIGH ALTITUDE INSTALLATION

When installing this appliance above altitudes of 4500 ft (1372 m) above sea level, the appliance must be properly de-rated and installed according to local codes or, in the absence of local codes, with the current National Fuel Gas Code ANSI Z223.1/ NFPA 54 in the U.S. or Installation Code CSA-B149.1 in Canada.

FIREPLACE MODIFICATIONS

Before installing this appliance into an existing fireplace, consider the following:

- Cutting any existing sheet metal parts in a solid fuel burning fireplace is prohibited.
- The fireplace flue damper should be removed or fixed in a fully open position.
- The fireplace and chimney must be constructed of non-combustible materials.
- The fireplace and chimney must be clean and in good working order.
- Chimney clean outs must fit properly.

If the existing fireplace is a Factory Built Fireplace or a Zero Clearance Fireplace, consider the following:

- Ensure there is a base of sheet metal below the appliance upon installation.
- Trim panels or surrounds must be removed if they seal ventilation openings in the fireplace.
- Refractory, glass doors, screen rails, screen mesh, and log grates must be removed from an existing fireplace before installing this appliance.
- If attached with fasteners, smoke shelves, shields, and baffles may be removed.
- If there is no gas supply line access hole present in an existing Factory Built Fireplace, a hole of $\varnothing 1.5"$ ($\varnothing 37.5$ mm) may be drilled through the lower sides or bottom of the fireplace can. This access hole must be plugged with non-combustible insulation after the gas supply line has been installed.

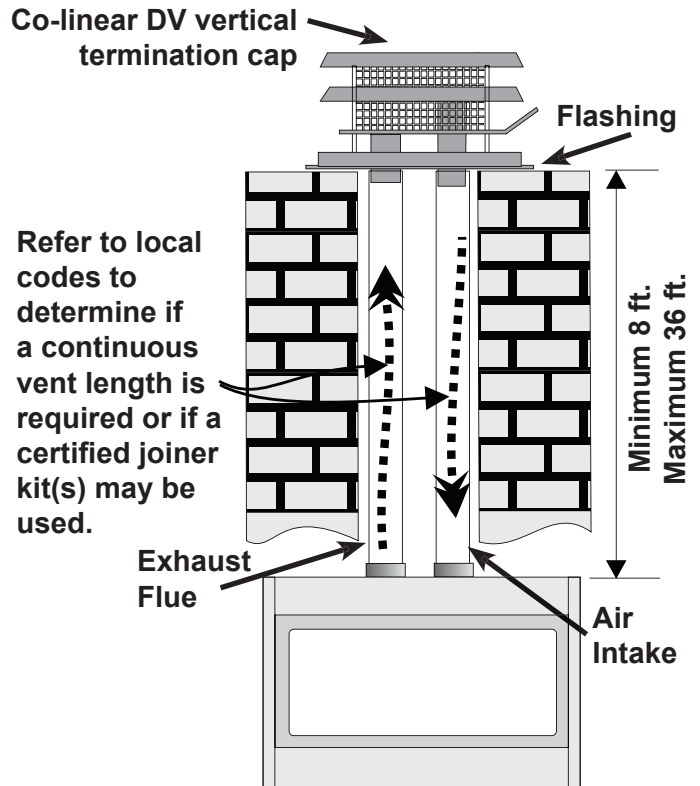

The label plate shown below (included with the appliance) must be permanently attached inside the cavity of the fireplace in a readily visible location.

WARNING: This fireplace has been converted for use with a gas fireplace insert only and cannot be used for burning wood or solid fuels unless all original parts have been replaced, and the fireplace reapproved by the authority having jurisdiction.

AVERTISSEMENT: Ce foyer a été converti pour l'utiliser avec un encastrable au gaz et ne peut pas être utilisé pour brûler du bois ou d'autres combustibles solides, à moins que toutes les pièces d'origine aient été remplacées et que le foyer ait été approuvé à nouveau par les autorités compétentes.

Minimum fireplace dimensions / Dimensions minimales du foyer	
Minimum flue size / Taille minimale de la cheminée	6" x 6" / 152mm x 152mm
Height / Hauteur	20" / 508 mm
Depth / Profondeur	15 1/2" / 394 mm
Width (rear) / Largeur (arrière)	22" / 559 mm
Width (front) / Largeur (avant)	29 1/8" / 740 mm

170-0166

INITIAL SETUP

1. Locate the x6 Levelling Bolts beneath the appliance (**Fig. 5**) and level the appliance from side to side and front to back. If levelling is not required, the bolts can be removed.
2. Remove the Safety Screen Trim by lifting it up and out from the appliance. (**Fig. 6**)
3. Locate the x2 door latch mechanisms on top of the firebox (**Fig. 7**) and pull the tabs forward and up to release the door.
4. Remove the Door by lifting it out of the lower door hooks (**Fig. 8**). **Note: Press the door glass into the door frame when removing as the glass is only held in place with silicone.** Remove the warning label affixed to the door glass at this time.
5. Remove the packaged contents from inside the Firebox and set aside.
6. If installing an optional Log Set or Glass Kit, please refer to the installation instructions provided with each specific Kit. If not installing any optional Kits, repeat **Steps 1 to 4** in reverse order to complete the initial setup.

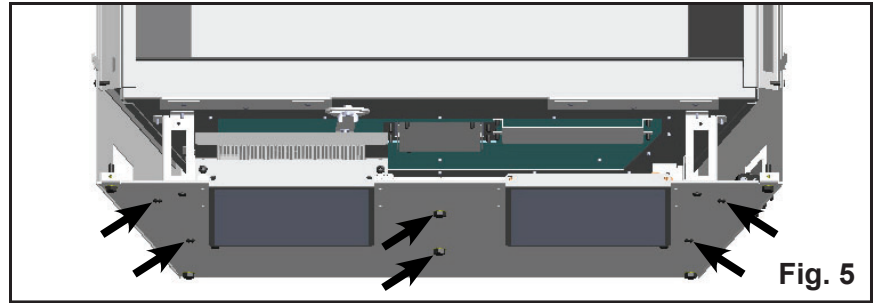

Fig. 5

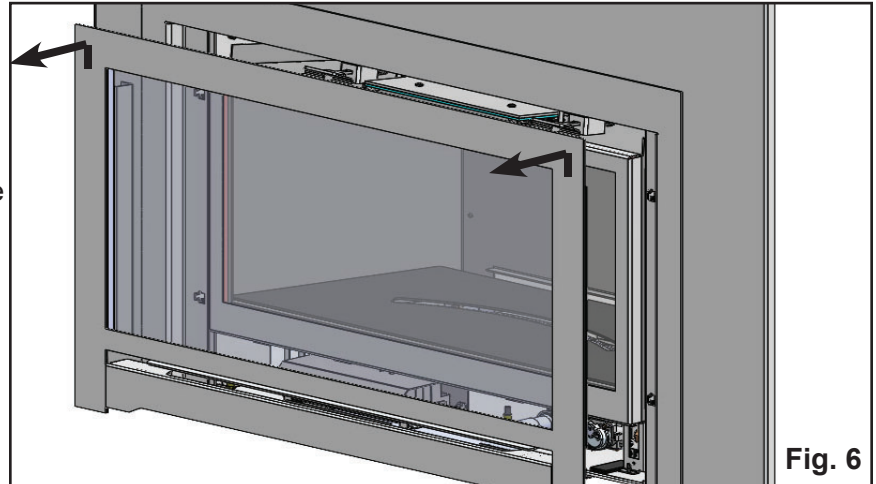

Fig. 6

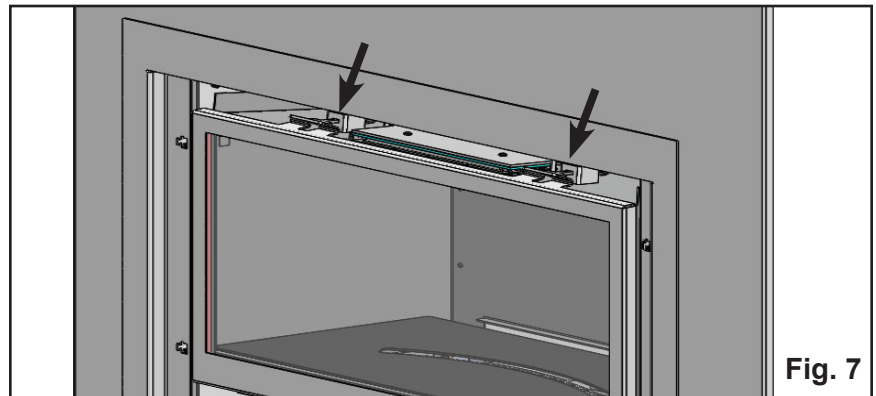

Fig. 7

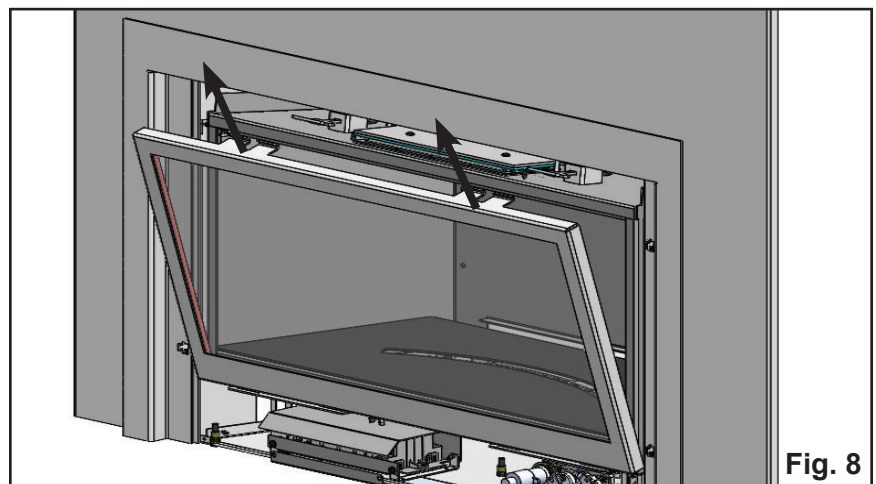
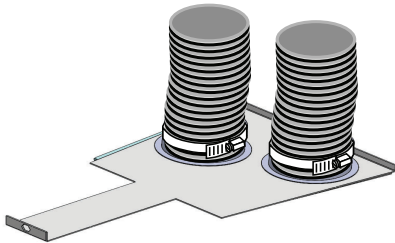

Fig. 8

VENT CONNECTOR

The Vent Connector is installed on the appliance from factory, but can be removed and attached to the Flex Vent and then reconnected to the appliance to ease the installation process. Follow these instructions to remove:

1. Unthread the 1/4-20 bolt at the top of the Firebox Can (**Fig. 9**) and remove.
NOTE: The Vent Connector Gasket must not be damaged or removed. Ensure that the gasket remains intact to prevent flue gas leakage.
2. Before making any connections, ensure the Flex Vent is properly installed within the chimney with approximately 3ft left out of the top of the chimney (tie off if necessary). **Ensure the flex vent is stretched as needed.**
3. Attach the Flex Vent to the Vent Connector and leave it hanging at the same height as the insert.



4. Slide the appliance into the fireplace while aligning the Vent Connector into the guides on top of the appliance. (**Fig. 10**)
5. Rethread the 1/4-20 bolt into the top of the appliance to affix the Vent Connector. (**Fig. 11**)
6. At the top of the chimney, remove any excess slack in the Flex Vent and attach the Vent Termination before sealing with flashing as required per code.

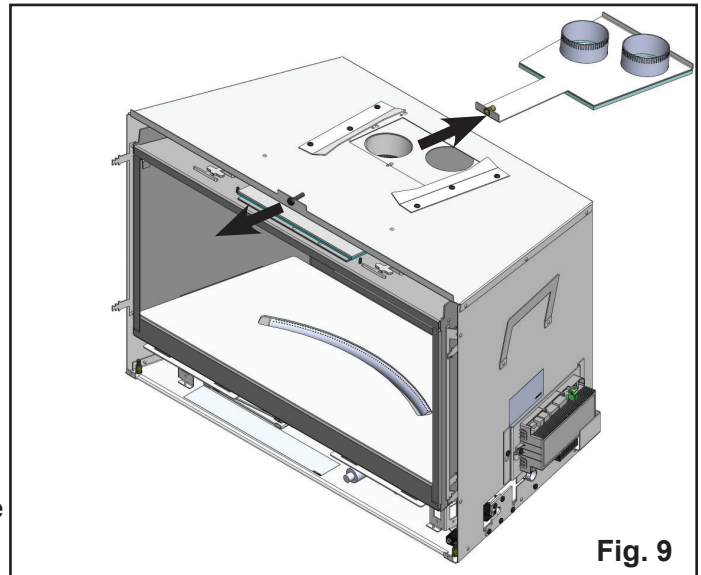

Fig. 9

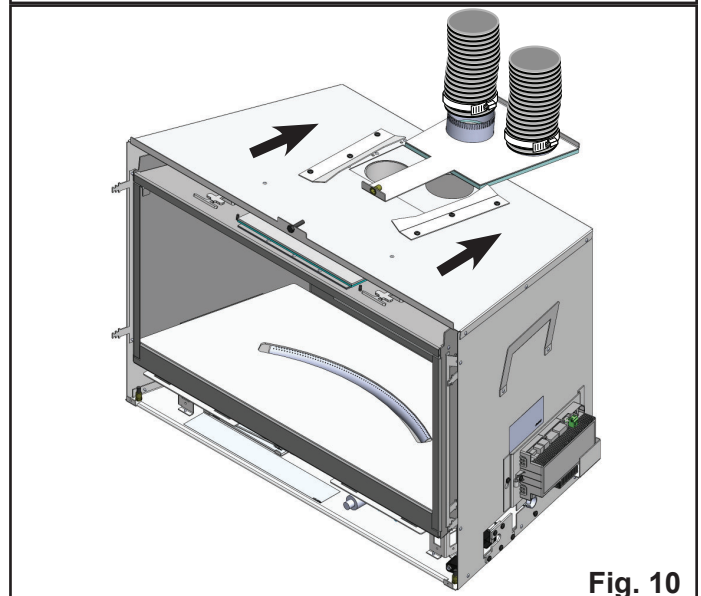

Fig. 10

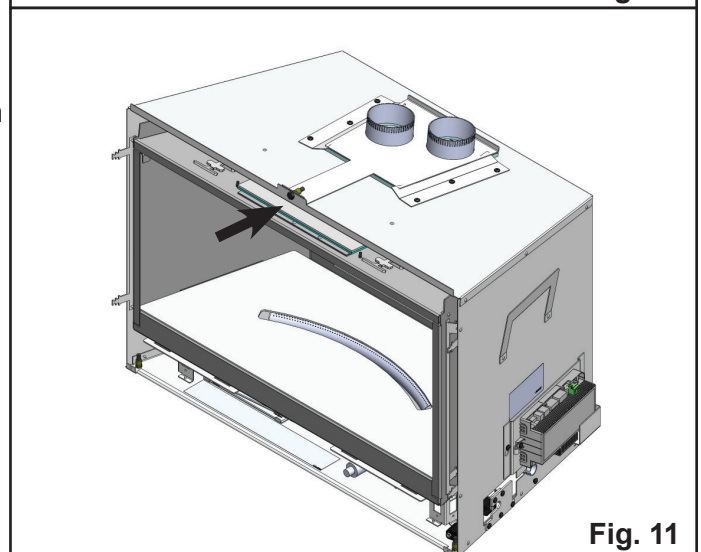

Fig. 11

MOBILE HOME INSTALLATION

This appliance is approved for installation in a manufacture (mobile) home. A manufactured home (USA only) or mobile home OEM installation must conform with the Manufactured Home Construction and Safety Standard Title 24 CFR Part 3280 or, when such a standard is not applicable, the Standard for Manufactured Home Installations ANSI / NCSBCS A225.1 or Standard for Gas Equipped Recreational Vehicles and Mobile Housing CSA Z240.4. Ensure the unit is permanently electrically grounded to the chassis of the home. This appliance must be securely fastened to the floor.

It is crucial that the structural integrity of the mobile home floor, wall, ceiling, and roof be maintained.

VENT RESTRICTOR

Due to the high draft produced by certain venting configurations, the vent restrictor may need to be adjusted to ensure maximum performance. If vent restriction is necessary, it can be adjusted as follows:

1. Ensure the appliance is turned off and is cool to touch.
2. Remove the Safety Screen Trim and Glass Door (refer back to “*INITIAL SETUP*”).
3. Reposition the restrictor tab into one of the x3 slots in the restrictor index plate to obtain desired flame. **(Fig. 12)**

4. Reinstall the Glass Door and Safety Screen Trim.

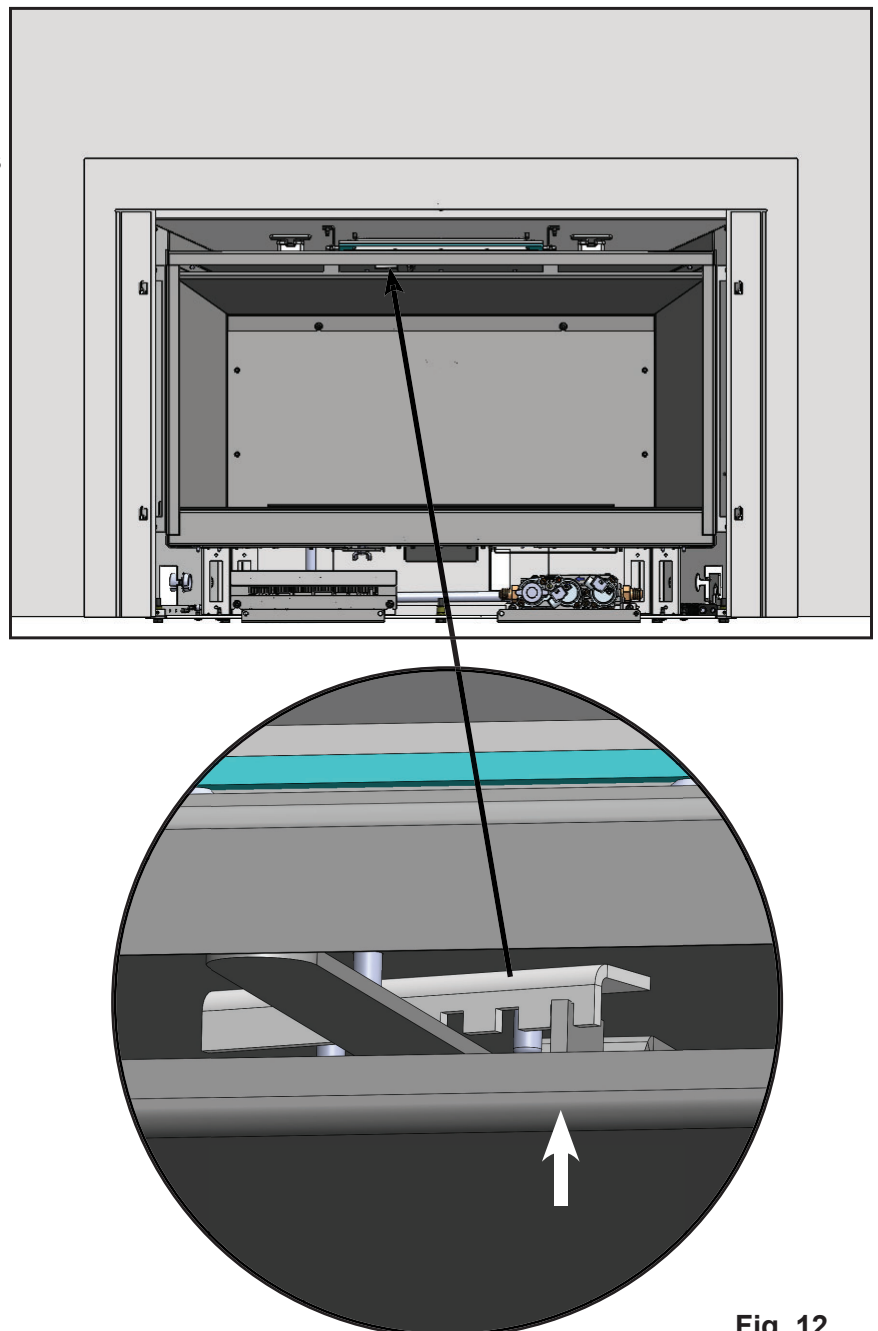
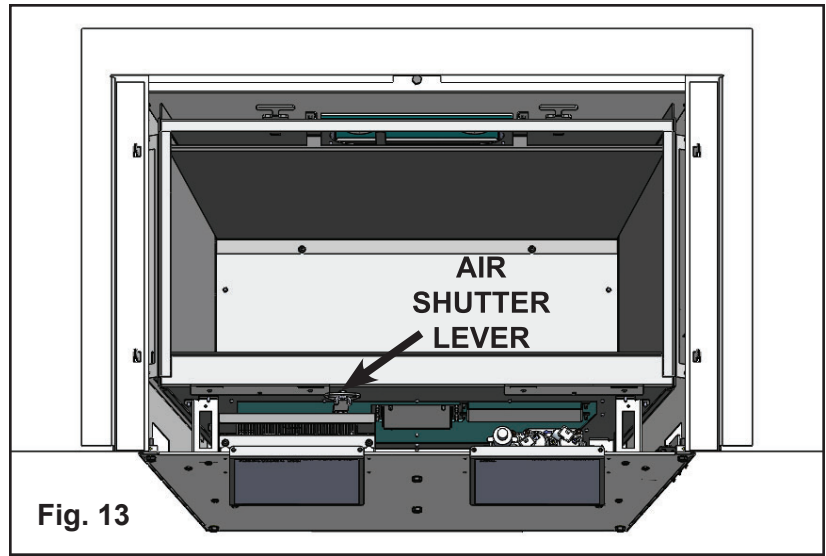

Fig. 12

AIR SHUTTER ADJUSTMENT

The air shutter allows the amount of air coming into the burner to be adjusted in order to accommodate different climates and venting arrangements. To access the Air Shutter Lever, follow these steps:

1. Remove the Safety Screen Trim (refer back to “*INITIAL SETUP*”).
2. Locate the Air Shutter Lever (**Fig. 13**) and loosen the wing nut securing it in place.
3. Start the pilot and then the burner. Allow the appliance to operate for 15 minutes before making any air adjustments.
4. The ideal flame will be blue at the base and light orange above. If the flames are short and mostly blue, the fireplace is getting too much air, therefore, the air shutter should be closed until the correct flames are achieved. To close, slide the air shutter in small increments to the right to reduce the amount of air in.
5. Flames that are very orange and have tall, dark, stringy tips are not getting enough air, therefore, the air shutter should be opened until the correct flames are achieved. To open, slide the air shutter in small increments to the left to increase the amount of air in.
6. When satisfied with the flame color, retighten the wing nut and reinstall the Safety Screen Trim.



PROFLAME 2 WIRING DIAGRAM

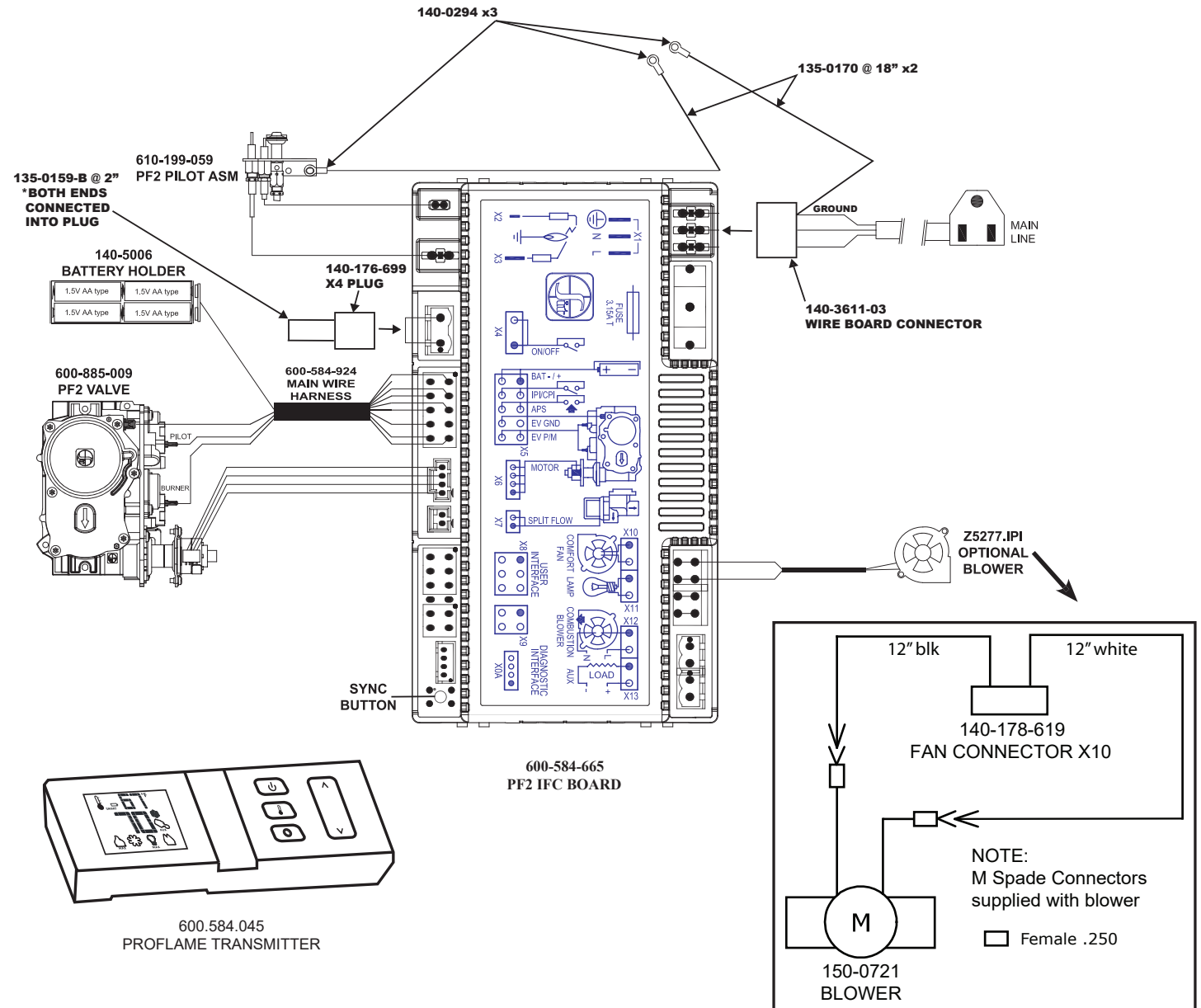

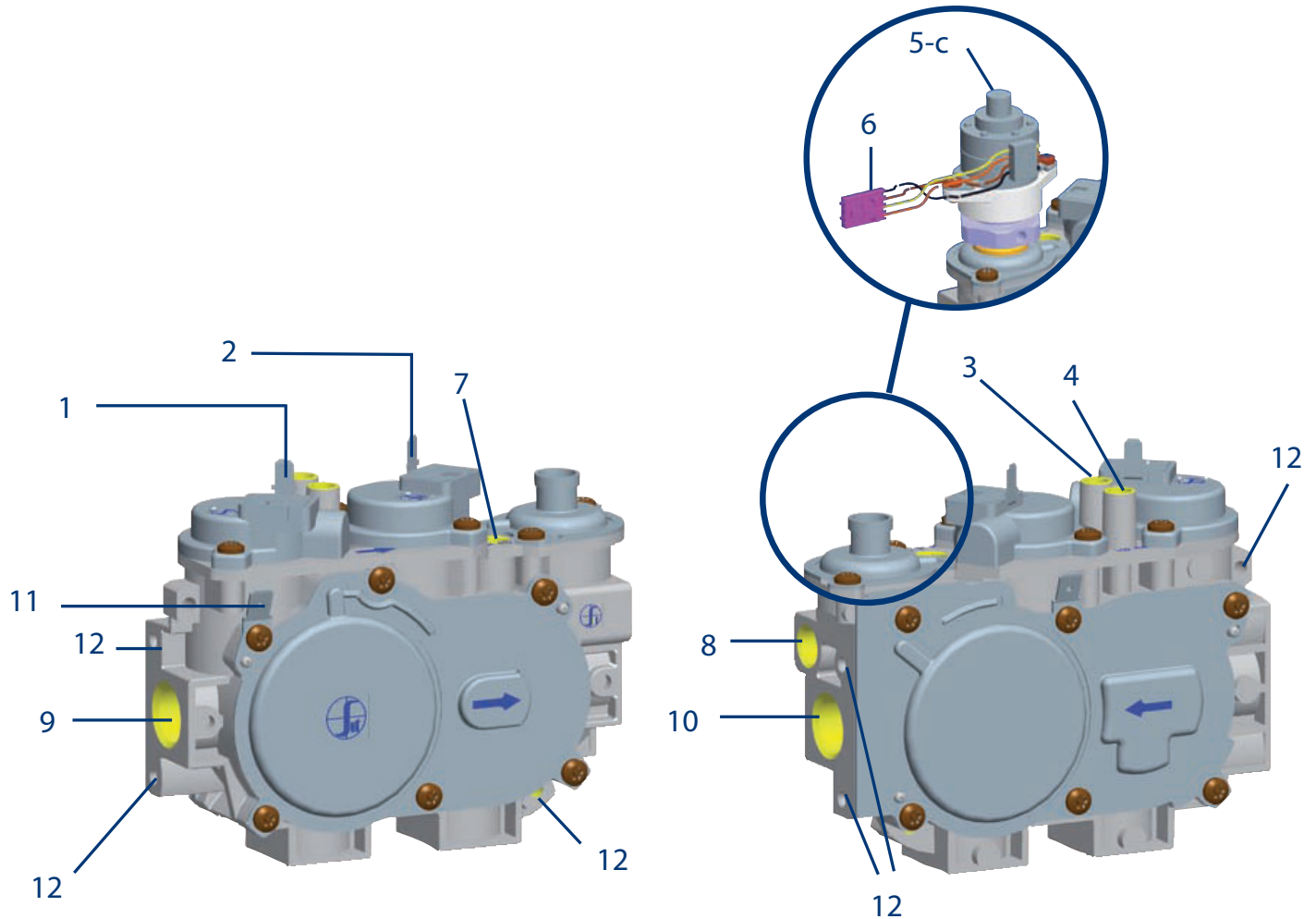
PROFLAME VALVE SCHEMATIC

885 PROFLAME VALVE	
1	ON-OFF solenoid EV1 terminals
2	ON-OFF solenoid EV2 terminals
3	Inlet pressure test point
4	Outlet pressure test point
5-c	Electrical pressure modulator device
6	Pressure modulator device terminal
7	Pilot adjusting screw
8	Pilot outlet
9	Gas inlet with protective seal
10	Gas outlet with protective seal
11	Ground connection
12	Mounting holes

FUEL CONVERSION

This appliance is approved to operate on either natural gas or propane. The factory pre-set is for natural gas. If converting to propane (or back to natural gas), a conversion kit is required. Each kit contains:

- S.Z0767 (LPG): #53 orifice, PF2 LP pilot orifice #35, LPG regulator, and conversion labels.
- S.Z0771 (NG): #41 orifice, PF2 NG pilot orifice #62, NG regulator, and conversion labels.

To convert from NG to LPG or reverse:

1. Ensure the appliance is turned off and cooled to touch.
2. Remove the safety screen, door, floor plate assembly, and burner assembly.
3. Change out main burner orifice with conversion kit orifice.
4. Change out pilot orifice with conversion kit orifice.
5. Remove valve.
6. Change out stepper motor pressure regulator.
7. Reinstall all components accordingly.

Note: If the appliance is installed at a higher altitude, refer back to “HIGH ALTITUDE INSTALLATION”.

⚠ WARNING

THIS CONVERSION KIT SHALL BE INSTALLED BY A QUALIFIED SERVICE PERSON IN ACCORDANCE WITH THE MANUFACTURER’S INSTRUCTIONS AND ALL APPLICABLE CODES AND REQUIREMENTS OF THE AUTHORITIES HAVING JURISDICTION. IF THE INFORMATION IN THESE INSTRUCTIONS IS NOT FOLLOWED EXACTLY, A FIRE, EXPLOSION, OR PRODUCTION OF CARBON MONOXIDE MAY RESULT CAUSING PROPERTY DAMAGE, PERSONAL INJURY, OR DEATH.

THE QUALIFIED SERVICE PERSON IS RESPONSIBLE FOR THE PROPER INSTALLATION OF THE KIT. THE INSTALLATION IS NOT COMPLETE UNTIL THE OPERATION OF THE CONVERTED APPLIANCE IS CHECKED AS SPECIFIED IN THE INSTRUCTION MANUAL SUPPLIED WITH THE KIT. BEFORE PERFORMING THIS PROCEDURE, ENSURE BOTH THE GAS SUPPLY AND THE ELECTRICAL SUPPLY ARE SHUT OFF.

Burner Removal:

1. Turn off the appliance and allow it to cool down completely.
2. Remove the Safety Screen Trim and Glass Door (refer back to “INITIAL SETUP”).
3. Remove the Floor Plate assembly (and glass panels if installed).
4. Remove the screw from the right hand side of the burner assembly.
5. Remove the burner by moving it to the right, then up, then out.

To re-install the burner, follow these steps in reverse. When installing, ensure the burner is centered within the curved slot of the floor plate.

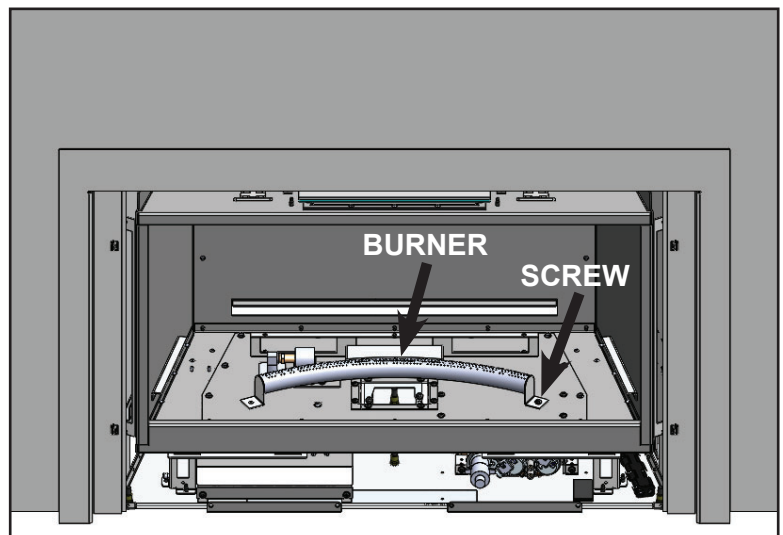

Pilot Orifice Conversion:

1. Remove the spring clamped hood from pilot and set aside (**Fig. 14**).
2. Unscrew orifice from pilot using a 4 mm allen key (**Fig. 15**), then screw in the new orifice. (**Fig. 16**)
3. Align the pilot hood with the tab and re-attach the pilot hood to the spring clamp.
4. Fill out the fuel conversion label and affix between the two labels on the control panel door.

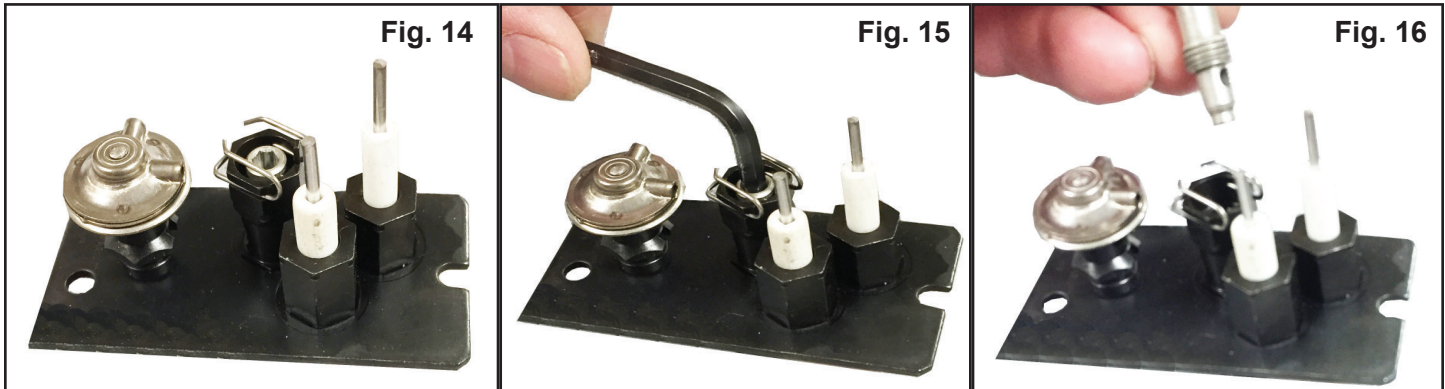
**Valve Removal:**

1. Turn off the appliance and allow it to cool down completely.
2. Shut off the gas to the appliance.
3. Remove the safety screen trim (refer back to *"INITIAL SETUP"*).
4. Disconnect all electrical connections to the Valve including ground wire.
5. Unfasten the x2 screws securing the valve in place and then pull it forward to access gas line couplings (**Note: do not pull the valve out too far as to prevent damage to the gas lines**).
6. Unthread the pilot gas supply line with a 7/16" wrench.
7. Unthread the gas inlet and gas outlet with a 3/4" wrench and then fully remove the Valve.

To re-install the Valve, follow these steps in reverse.

Note: When installing a new valve, check if any unused ports are plugged. Confirm proper outlet pressure (refer back to *"GAS CONNECTIONS"*) and check for leaks.

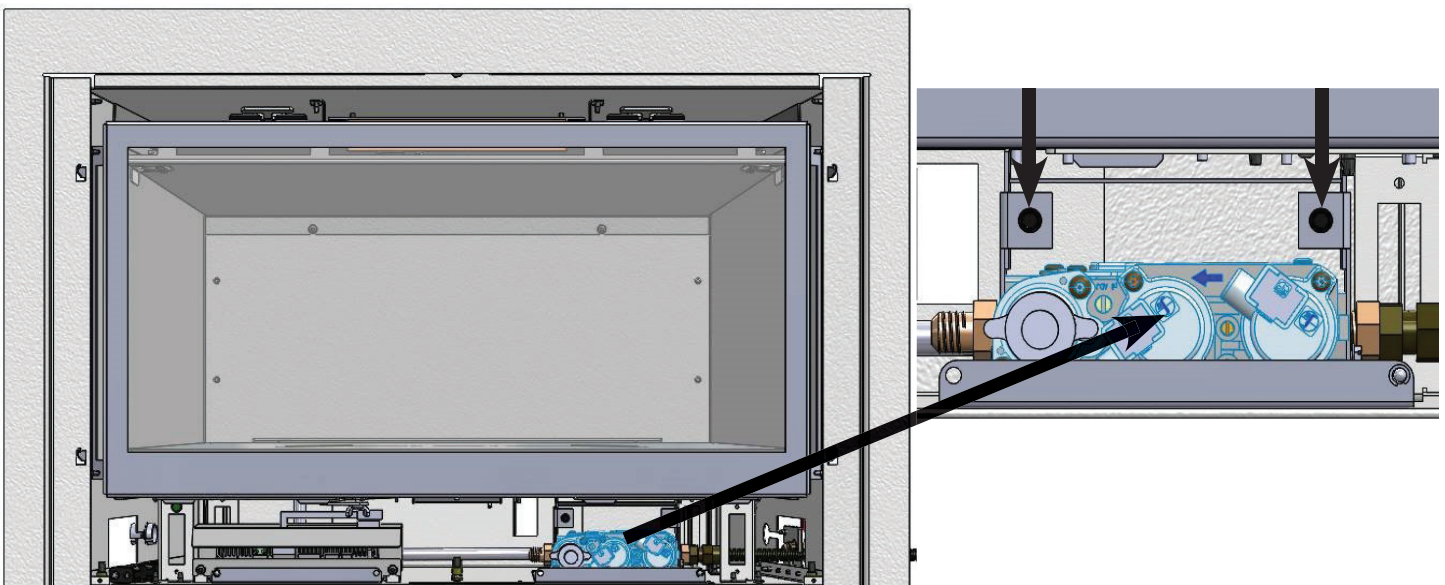

STEPPER MOTOR PRESSURE REGULATOR CONVERSION KIT INSTALLATION OR REPLACEMENT INSTRUCTIONS.

Verify that the following items are present in the package.

- Pressure regulator assembly (E)
- Two (2) screws (F)
- Identification label (G)
- Installation instructions (this document).

- 1 Shut off the gas supply to the valve and shut down the electric supply.
- 2 See Fig. 1. Using a Torx T20, or slotted screwdriver, remove and discard the two (2) pressure regulator mounting screws (A), pressure regulator tower (B), and the spring and diaphragm assembly (C), (If applicable).
- 3 Ensure the rubber gasket (D), which is prefitted as part of assembly (E), is properly positioned, see Fig. 2, otherwise fit the gasket as shown Fig. 2.
- 4 Install the new STEPPER MOTOR pressure regulator assembly, as shown in Fig. 3 and Fig. 4. Use the supplied screws (F), M4 x 0.7 threaded, length of thread $L=(16\text{ mm} + 0 - 0.5\text{ mm})$, steel material, resistance class 8.8 (see Fig. 5).
- 5 Manually thread the two conversion kit mounting screws into the valve body. Use a standard screwdriver or T20 Torx bit and tighten to the screws with a fixing torque of $25\text{lb-in} \pm 5\%$.
IN THE EVENT THAT THE THREADS OF THE VALVE ARE STRIPPED OR DAMAGED, **REPLACE THE VALVE.**
- 6 Install the enclosed identification label (G) to the valve body where it can be easily seen.
- 7 Make STEPPER MOTOR and valve electrical connections, apply gas to system and relight appliance according to manufacturers instructions.
- 8 With the main burner "ON", test the new pressure regulator assembly for leaks using a soap solution.
- 9 Relight the main burner and verify proper burner ignition and operation.

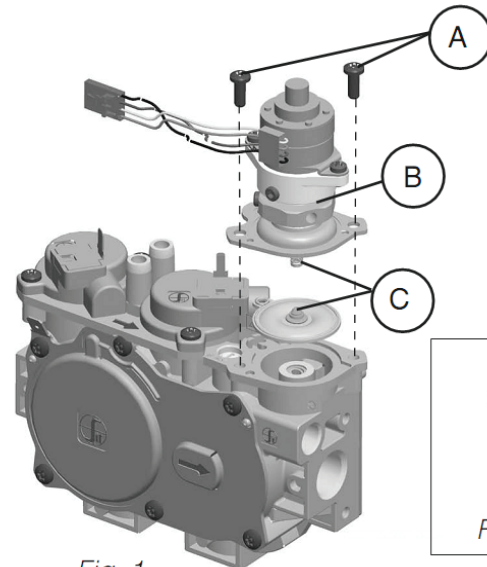

Fig. 1

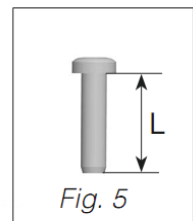

Fig. 5

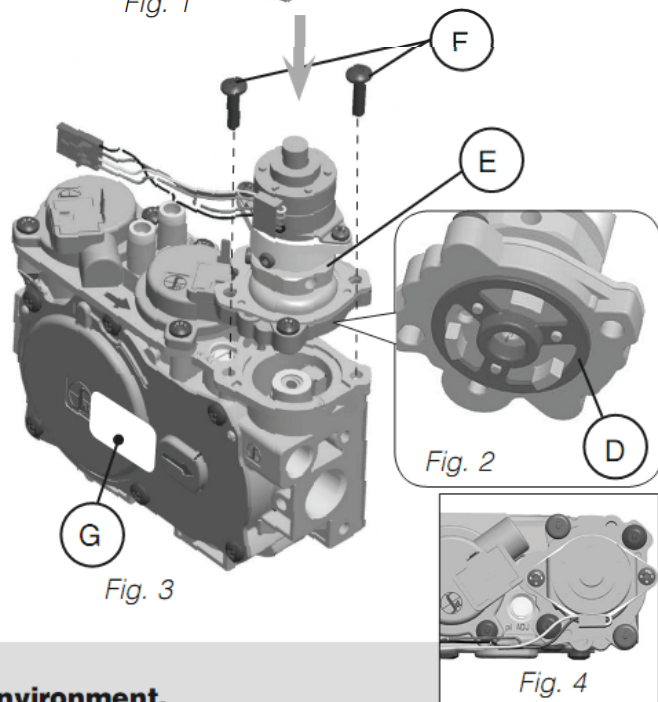

Fig. 3

Fig. 2

Fig. 4

WARNING!
Installation should be carried out in a clean environment.

WARNING!
This modulating conversion kit must **ONLY** be applied as part of a conversion kit supplied by the **APPLIANCE MANUFACTURER** for the specific appliance, and type of gas, being converted.

WARNING!
Correct operation of the system cannot be guaranteed if the conversion kit or valve has been dropped or has sustained a strong impact.

INSTALLER NOTICE. These instructions must be left with appliance.

FOR YOUR SAFETY, READ BEFORE LIGHTING

WARNING: If you do not follow these instructions exactly, a fire or explosion may result causing property damage, personal injury or loss of life.

- A. This appliance is equipped with an ignition device which automatically lights the pilot. Do not try to light the pilot by hand.
- B. BEFORE LIGHTING, smell all around the appliance area for gas. Be sure to smell next to the floor because some gas is heavier than air and will settle on the floor.
WHAT TO DO IF YOU SMELL GAS:
 - Do not try to light any appliance.
 - Do not touch any electric switch; do not use any phone in your building.
 - Immediately call your gas supplier from a neighbour's phone. Follow the gas suppliers instructions.
 - If you cannot reach your gas supplier, call the fire department.
- C. Do not use this appliance if any part has been under water. Immediately call a qualified service technician to inspect the appliance and to replace any part of the control system and any gas control which has been under water.

LIGHTING INSTRUCTIONS

1. **STOP!** Read the safety information above.
2. Set the thermostat to the lowest setting.
3. Turn off all electric power to the appliance.
4. Do not attempt to light the pilot by hand.
5. Wait five (5) minutes to clear out any gas. Then smell for gas, including near the floor. If you smell gas, **STOP!** Follow "B" in the safety information above. If you don't smell gas, go to the next step.
6. You must now synchronize the wall mount / remote with the IFC board (for 1st time use) by pressing the SYNC button **FIG 1** followed by pressing the "ON" button on the wall mount / remote. (**FIG 2**)
7. Press the "ON" button on the wall mount / remote. (**FIG 2**)
8. If the appliance will not operate, follow the instructions "To Turn Off Gas To Appliance" and call your service technician or gas supplier.

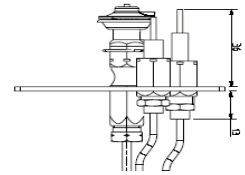

TO TURN OFF GAS TO THE APPLIANCE

1. Press the "OFF" button on the wall mount / remote. (**FIG 1**)
2. Turn off all electric power to the appliance.

WARNING

Improper installation, adjustment, alteration, service or maintenance can cause injury or property damage. Refer to the owner's information manual provided with this appliance. For assistance or additional information, consult a qualified installer, service agency or your gas supplier.

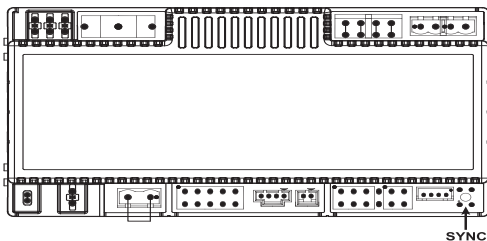

FIG 1: IFC BOARD

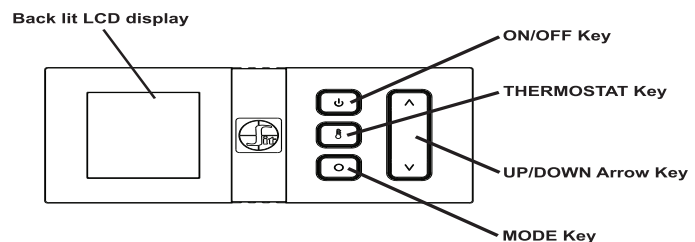

FIG 2: WALL MOUNT / REMOTE

Note: Turning on the appliance when it has been off for a while may cause condensation to appear on the glass. This is a normal occurrence as your appliance heats up.



SIT PILOT FLAME

Note: The pilot flame should be blue with little or no yellow tips.

PROFLAME 2 REMOTE OPERATION

The Proflame 2 System consists of a Wall Mount Remote and an Integrated Fireplace Controller (IFC). The remote provides control for the following appliance functions:

1. Main Burner ON/OFF
2. Main Burner flame modulation (6 levels)
3. Choice of continuous or intermittent pilot (CPI or IPI)
4. Thermostat and Smart thermostat functions
5. Fan ON/OFF and speeds

The Proflame Remote has a simple button layout and an informative LCD display (**Fig. 19**). A Mode Key is provided to index between the features and a Thermostat Key is used to turn the appliance ON/OFF or index through Thermostat functions (**Fig. 20**). Additionally, the optional Connect Smart Home Kit is available to allow the unit to be controlled via smart phone app.

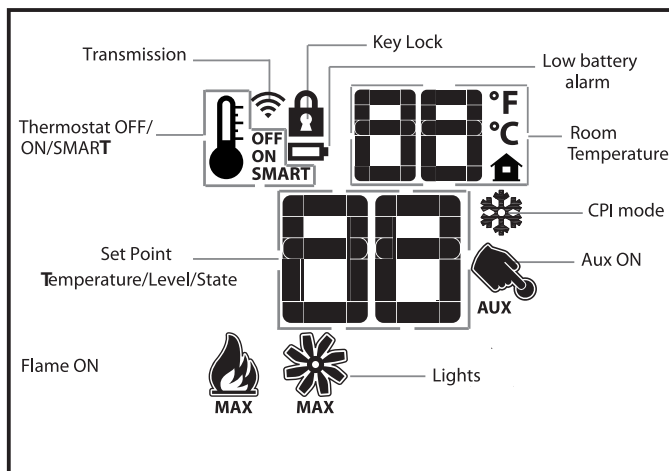

Fig. 19: Remote LCD Display

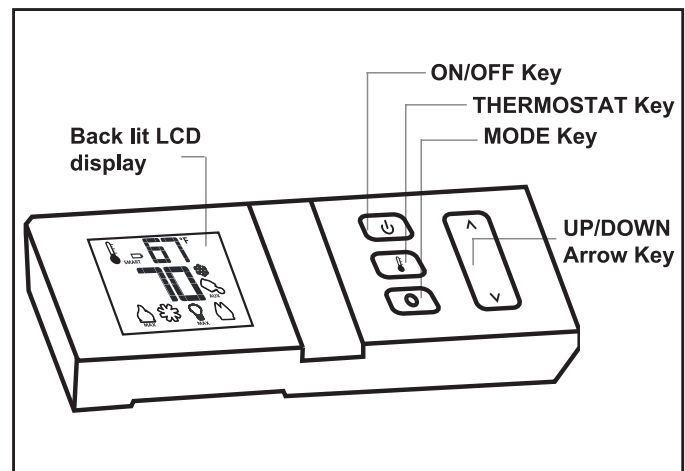
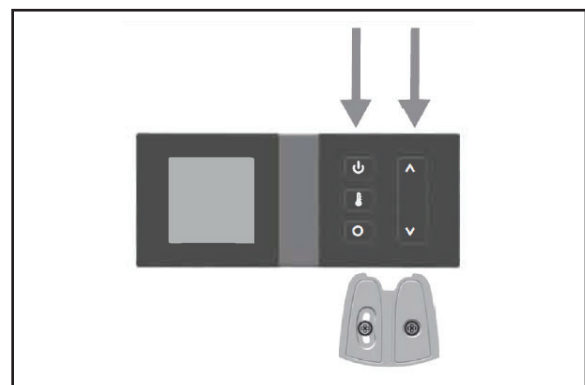
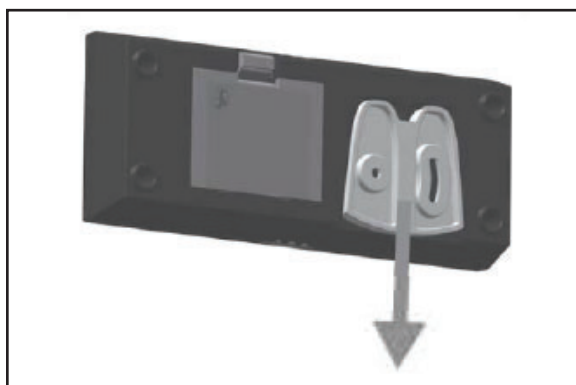

Fig. 20: Proflame Transmitter

Wall Mounting

The remote is supplied with an adapter for wall mounting. Ensure the remote is positioned 5 ft (1.5 m) above floor level and well away from heat sources, kitchens, doors, or windows. Metallic structures or radio interferences can reduce the operative distance of the remote. To install the wall adapter:

- Detach the adapter from the body of the remote.
- Position the adapter on a level plane against a wall and mark the holes to be drilled.
- After drilling the holes, fasten the adapter to the wall using the supplied mounting hardware.
- Insert the remote into the adapter.



Initializing the System

Install three AAA batteries into the remote battery bay, located on its base. Power up the appliance the IFC then push the red “sync” button on the IFC. Next, push the ON button on the remote. The IFC will “beep” to indicate the remotes’s command is accepted and sets to the particular code of the remote.

**Temperature Indication Display**

With the system in the “OFF” position, press the Thermostat Key and the Mode Key at the same time. Look at the LCD screen on the remote to verify that a C or F is visible to the right of the Room Temperature display.

**Turn On the Appliance**

With the system OFF, press the ON/OFF Key on the remote. The LCD display will show some other active Icons on the screen. At the same time the IFC will activate the appliance. A single “beep” will confirm reception of the command.

Turn Off the Appliance

With the system ON, press the ON/OFF Key on the remote. The LCD display will only show the room temperature. At the same time, the IFC will turn OFF the appliance. A single “beep” will confirm reception of the command.



Flame Control

This appliance has six flame levels. With the system ON and the flame level in the high position, pressing the Down Arrow Key once will reduce the flame height by one step, and so on until the flame is turned off. The Up Arrow Key will increase the flame height in a similar fashion. If the Up Arrow Key is pressed while the system is on but the flame is off, the flame will come on in the high position. A single “beep” will confirm reception of commands.

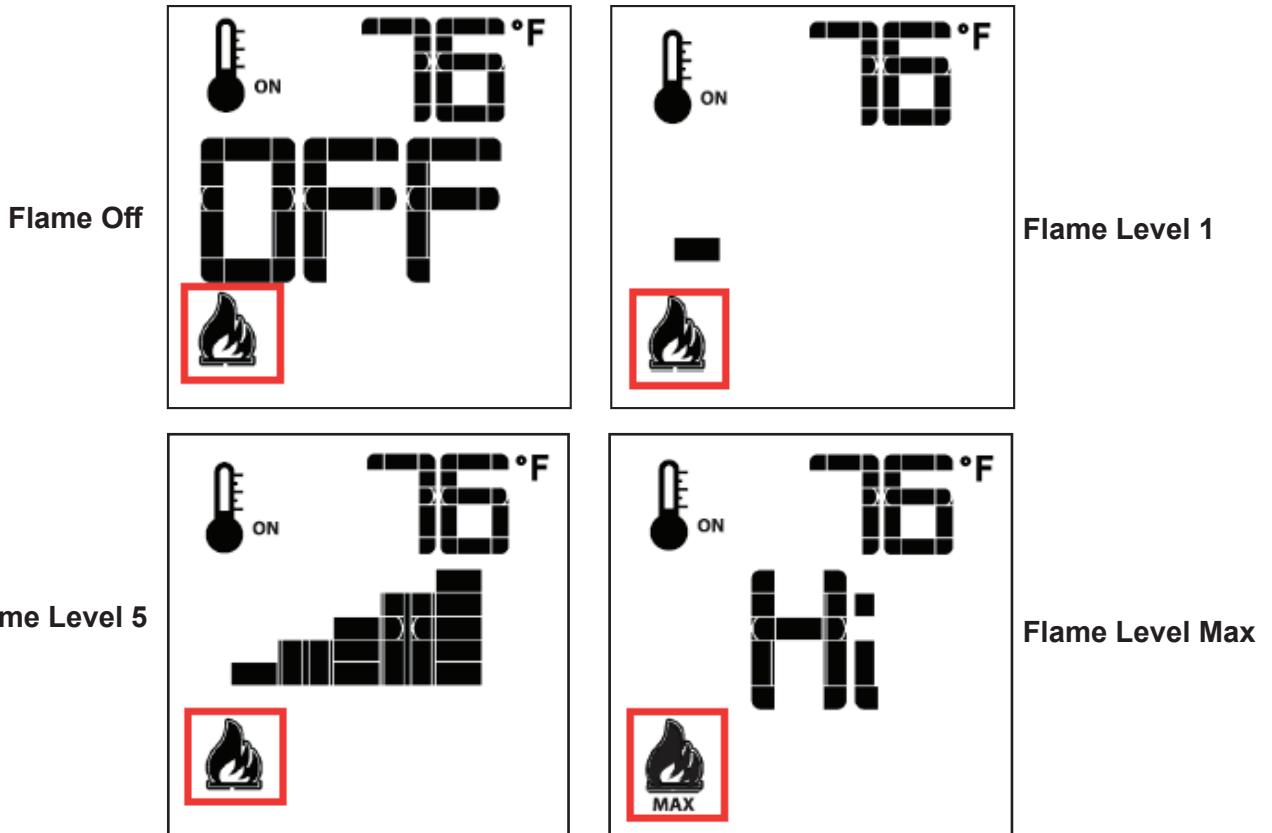

Room Thermostat

The remote operates as a wall thermostat and can be set to a desired temperature to control comfort level in a room. To activate this function, press the Thermostat Key. The LCD display will change to show that the room thermostat is “ON” and the set temperature will be displayed. To adjust the set temperature, press the Up or Down Arrow Keys until the desired set temperature is displayed on the LCD screen.

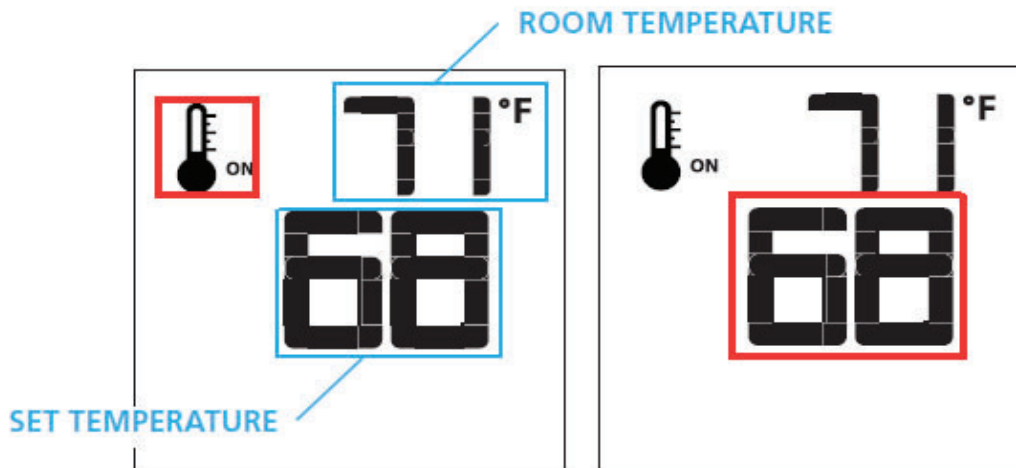

Smart Thermostat

The Smart Thermostat function adjusts the flame height in accordance to the difference between the set point temperature and actual room temperatures. As the room temperature gets closer to the set point, the Smart Function will modulate the flame down. To activate this function, press the Thermostat Key until the word “SMART” appears to the right of the temperature bulb graphic. To adjust the set temperature, press the Up or Down Arrow Keys until the desired set temperature is displayed on the LCD screen.

Note: When Smart Thermostat is activated, manual flame height adjustment is disabled.

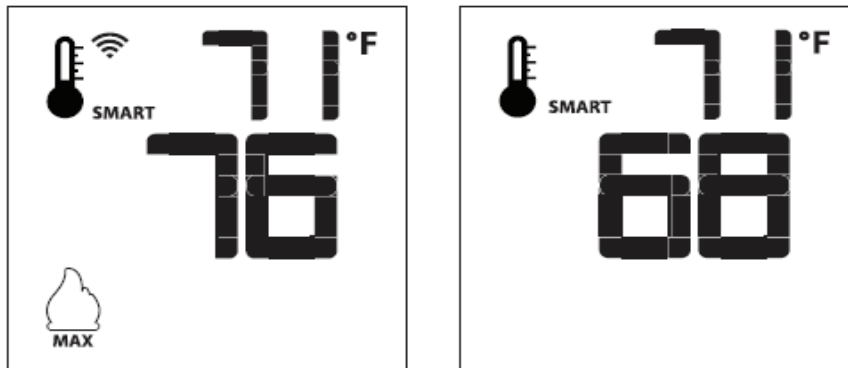

Fan Speed Control

If the appliance is equipped with a Fan Kit, the speed of the fan can be controlled and adjusted through six speeds by the Proflame system. To activate this function, use the Mode Key to index to the fan control icon. Use the Up/Down Arrow Keys to turn the fan ON/OFF or adjust the speed. A single “beep” will confirm reception of the command.

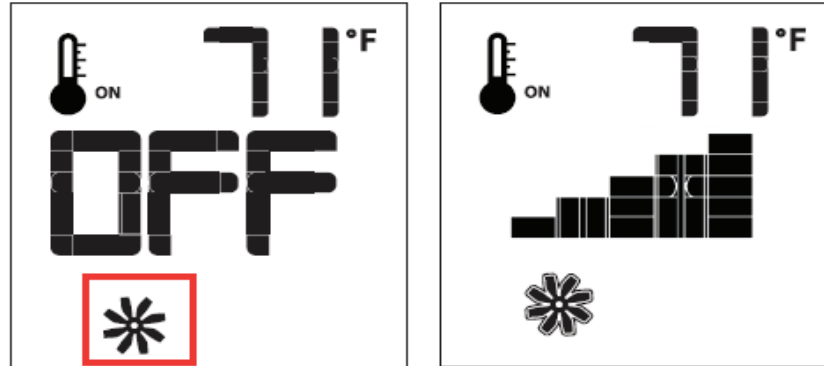

Remote Auxiliary Relay Control

The auxiliary function controls the AUX relay outlet. To activate this function use the Mode Key to index to the AUX icon. Pressing the Up Arrow Key will activate the outlet. Pressing the Down Arrow Key will turn the outlet off. A single “beep” will confirm the reception of the command.

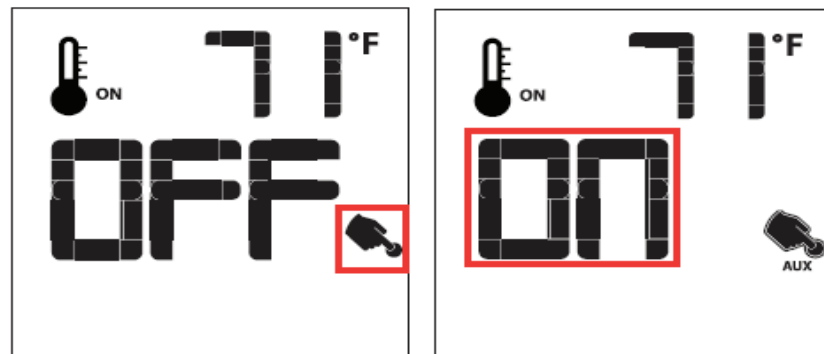

Continuous Pilot / Intermittent Pilot (CPI/IPI) Selection

With the system in “OFF” position, press the Mode Key to index to the CPI mode icon. When enabled it will act as a Standing Pilot unit with an automatic shutoff timer that will turn the pilot off after 7 days. Pressing the Up Arrow Key will activate the Continuous Pilot Ignition mode (CPI). Pressing the Down Arrow Key will return to IPI. A single “beep” will confirm the reception of the command.

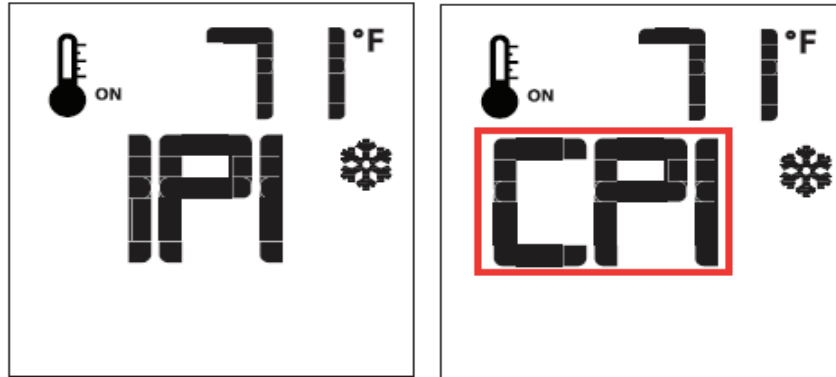

Key Lock

This function will lock the keys to avoid accidental or unsupervised operation. To activate this function, press the MODE and UP Keys at the same time. To deactivate this function, press the MODE and UP Keys at the same time.

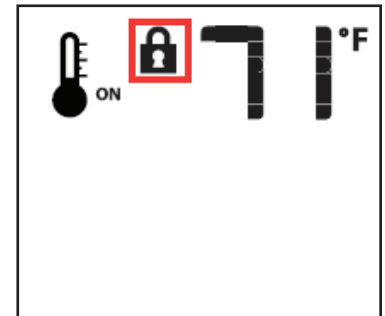

Low Battery Power Detection

The life span of the remote batteries depends on various factors: quality of the batteries used, the number of ignitions of the appliance, the number of changes to the room thermostat set point, etc. When the remote batteries are low, a Battery Icon will appear on the LCD display before all battery power is lost. When the batteries are replaced, this Icon will disappear.

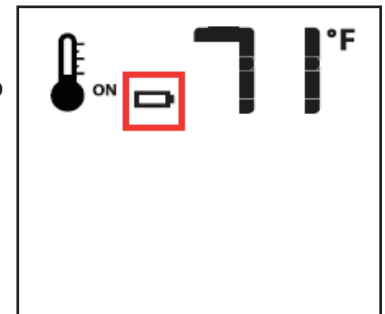

NOTE:

- THE TRANSMITTER AND RECEIVER ARE RADIO FREQUENCY DEVICES. PLACING THE TRANSMITTER IN OR NEAR METAL MAY SEVERELY REDUCE THE SIGNAL RANGE. METALLIC STRUCTURES OR RADIO INTERFERENCES CAN REDUCE THE OPERATIVE DISTANCE OF THE DEVICE DEPENDING ON TYPE OF FIREPLACE, INSTALLATION AND ENVIRONMENT.
- TURN “OFF” THE MAIN GAS SUPPLY OF THE APPLIANCE DURING INSTALLATION OR MAINTENANCE OF THE RECEIVER DEVICE.
- TURN “OFF” MAIN GAS SUPPLY TO THE APPLIANCE PRIOR TO REMOVING OR REINSERTING THE BATTERIES IN THE BATTERY HOLDER.
- IN CASE OF REMOTE CONTROL MALFUNCTION TURN OFF THE IFC DEVICE USING THE “ON/OFF” MAIN SWITCH.
- THE DEVICE IS NOT SUITABLE FOR THE USE OF RECHARGEABLE BATTERIES AND ITS OPERATIVE DISTANCE IS REDUCED WITH LOW BATTERY LEVEL.

ROUTINE MAINTENANCE

Blaze King recommends that you regularly:

- Clean away any lint accumulations or debris from the grills and combustion/convection passageways.
- Keep the area around the appliance free from combustible materials such as paper, wood, clothing, gasoline, flammable solids, liquids, and vapors.
- Visually check the height and color of the burner and pilot flames. The pilot flame should be blue with little or no yellow on the tips.
- Check for unusual noises or odors during operation of the appliance.
- Check the vent terminal for any debris accumulation, damage, or obstruction by plants.

It is also recommended to have your appliance serviced by a qualified service technician once a year:

1. Remove the door (refer back to “*INITIAL SETUP*”) and clean the inside of the glass (see below).
2. Remove and clean the glass side and floor panels (see below).
3. Remove and clean the floor panel assembly. Check the burner to ensure all ports are clear and clean. Check the pilot assembly to make sure it is not blocked by anything.
4. Completely inspect the appliance and the venting system.
5. Check the safety system of the gas valve.

CLEANING SURFACES

Painted, powder coated, or porcelain enamelled surfaces should be wiped periodically with a damp cloth. Ensure the appliance has cooled down completely before cleaning. Do not use cleaning agents as they may leave a residue which can become permanently etched into the surface.

CLEANING DOOR GLASS

One of the by-products of combustion and moisture within the firebox is a white film which forms on the glass door. Initial curing of the appliance can also leave a slight film on the glass, which can be addressed by:

1. Turn off the appliance and allow it to cool down completely.
2. Remove the door from the firebox (refer back to “*INITIAL SETUP*”)
3. Check the gasket material on the back of the glass. Ensure that it is attached and intact.
4. Clean the glass with a mild glass cleaner and a soft cloth.

Slight soiling of SCHOTT ROBAX® panels can be removed using conventional glass cleaning products, provided they are used according to instructions of use, which means cleaning on cold surfaces. The residues should be removed since chemical attack is possible on exposure to temperature.

Note: Do not use scouring pads/agents or abrasive cleaners as they may damage the glass surface.

DOOR GLASS REPLACEMENT

The door must be removed to replace the door glass (refer back to “*INITIAL SETUP*”). Ensure the appliance is turned off and cooled down completely before handling any components. The door glass in this appliance is a 5 mm high temperature anti-reflective ceramic glass. In the event the glass breaks or cracks, contact your dealer for a factory replacement (see “*PARTS LIST*”). The glass must be purchased from a Blaze King dealer.

⚠ WARNING

DO NOT OPERATE THE APPLIANCE WITH THE DOOR GLASS REMOVED, CRACKED, OR BROKEN. DOING SO MAY RESULT IN THE RELEASE OF TOXIC FUMES AND/OR CARBON MONOXIDE WHICH MAY RESULT IN POISONING. GLASS REPLACEMENT SHOULD BE DONE BY A QUALIFIED SERVICE PERSON.

SAFETY SCREEN REPLACEMENT

This appliance is supplied with a pre-installed safety screen. If the safety screen becomes damaged, contact your dealer for a factory replacement (see “*PARTS LIST*”). Refer back to “*INITIAL SETUP*” for removal procedure. **Ensure the screen mesh is facing outward, farthest from door glass.**

M&G DURAVENT DIRECTVENT PRO / GS SYSTEM PARTS LIST

DESCRIPTION	PART	OLD PART
Aluminum Flex Length - 3"	3DFA-35	
Flex Coupling - 3"	3DFA-FC	
Co-Axial to Co-linear Appliance Connector	46DVA-GCL	
Chimney Liner Termination Kit	46DVA-GK	
Co-Linear Kit w/ Flex	46DVA-CL33-25	
Co-Linear Kit w/ Flex	46DVA-CL33	
Co-Linear Kit w/ Flex	46DVA-CL33-H	
Vertical Termination Kit, Prairie Cap	46DVA-CL33P	
Direct Vent Factory-Built Reline Kit	46DVA-CL33KFB	
Sconce Termination Cap - aluminum	46DVA-HSC	
Sconce Termination Cap - stainless steel	46DVA-HSC-S	
Sconce Termination Cap - copper	46DVA-HSC-C	
Vertical High Wind Termination Cap (must be used for all vertical terminations)	46DVA-VCH	991
Square Horizontal Termination Cap - aluminum	46DVA-HC	
Square Horizontal Termination Cap - stainless steel	46DVA-HC-S	
Square Horizontal Termination Cap - copper	46DVA-HC-C	
Horizontal. Square Termination Cap	-	984

ICC PARTS LIST

DESCRIPTION	PART
CO-LINEAR ALUMINUM FLEX KITS	
Standard 3"x3" Co-linear Flex Kit: Includes TM-IVT, TF-MFR & two 35' lengths of 3" diameter 2-ply AL flex	TM-ALK33
Traditional 3"x3" Co-linear Flex Kit: Includes TM-CT3, TF-CTF & two 35' lengths of 3" diameter 2-ply AL flex	TM-ALT33
ALUMINUM FLEX ROLLS (Flex only)	
35' Aluminum Flex Roll (3" or 4")	TC-ØAL35
50' Aluminum Flex Roll (3" or 4")	TC-ØAL50
ADAPTERS	
Co-Linear Termination Adapter 3x3	TM-CTA
FLEX TO FLEX CONNECTORS	
Flex Liner Connector (3" or 4")	TM-CFAAØ
CAPS (all ICC terminations are certified for high wind)	
Insert Vertical Termination	TM-IVT
Traditional Co-Linear Chimney Cap - 3x3	TM-CT3
Horizontal Termination Square	TM-4HT
Horizontal Termination Round	TM-4RHT

VENTING COMPONENTS

BDM PARTS LIST	
ORDER #	DESCRIPTION
PROFORM 35' INSERT CO-LINEAR TERMINATION KITS:	
94203370	3"X3"VCL PROFORM KIT 35'X 2
94203370B	3"X3"VCL PROFORM KIT 35'X 2 W/ BLACK CAP
PROFORM INSERT CO-LINEAR INSULATED KITS:	
942103360	3"X3"VCL PROFORM INSULATED KIT 30'X 2
942103360B	3"X3"VCL PROFORM INSULATED KIT 30'X 2 W/ BLACK CAP
942103370	3"X3"VCL PROFORM INSULATED KIT 35' X 2
942103370B	3"X3"VCL PROFORM INSULATED KIT 35' X 2 W/ BLACK CAP
PROFORM INSERT CO-LINEAR NON-INSULATED KITS:	
94203360	3"X 3" VCL PRO FORM KIT 30' X 2
94203360B	3"X 3" VCL PRO FORM KIT 30' X 2 W/ BLACK CAP
INSERT CO-LINEAR TERMINATION CAPS:	
940033	3"X 3" VCL PRO FORM TERM CAP
940033B	3"X 3" VCL PRO FORM TERM CAP - BLACK
940033C	3"X 3" VCL PRO FORM TERM CAP - COPPER
VERTICAL CO-LINEAR TEMINATION CAPS W/SS BASE:	
9400330808SS	3"X3" VCL PRO FORM TERM CAP W/ 8X8 SS BASE
9400330808SSB	3"X3" VCL PRO FORM TERM CAP W/ 8X8 SS BASE BLACK
9400330808SSC	3"X3" VCL PRO FORM TERM CAP W/ 8X8 SS BASE COPPER
9400330813SS	3"X3" VCL PRO FORM TERM CAP W/ 8X13 SS BASE
9400330813SSB	3"X3" VCL PRO FORM TERM CAP W/ 8X13 SS BASE BLACK
9400330813SSC	3"X3" VCL PRO FORM TERM CAP W/ 8X13 SS BASE COPPER
9400331313SS	3"X3" VCL PRO FORM TERM CAP W/ 13X13 SS BASE
9400331313SSB	3"X3" VCL PRO FORM TERM CAP W/ 13X13 SS BASE BLACK
9400331313SSC	3"X3" VCL PRO FORM TERM CAP W/ 13X13 SS BASE COPPER

AMERIVENT PARTS LIST	
PART	DESCRIPTION
4DCAB33	Co-Linear Appliance Adapter, 3" and 3"
4DCAT33	Co-Linear Top Kit with flashing, 3" and 3"
4DHC	Horizontal Cap Round
4DHCS	Horizontal Cap Square

OLYMPIA PARTS LIST

KITS	
PART	DESCRIPTION
VDV-CKVCCH33	3"x3" Co-Linear Kit that includes a High Wind Vertical Cap, 2 3"x35' rolls of Aluminum Liner and 4 hose clamps
VDV-CK33CC	Square Style 3"x3" Stainless Steel Co-Linear Cap and 2 Hose clamps. The cap has 2 built-in Hose Clamps
VDVB-CK33CC	Square Style 3"x3" Galvanized Powder Coated Black Cap and 2 Hose clamps. The cap has 2 built-in Hose Clamps
PARTS	
VDV-CC33	Square Style 3"x3" Co-Linear Cap Stainless Steel
VDVB-CC33	Square Style 3"x3" Co-Linear Cap Galvanized and Powder Coated Black
VDV-VCCH33	3"x3" High Wind Co-Linear Cap
VDV-HC04	Horizontal Cap
VDV-VCH04	Vertical Termination Cap
VDV-VCC33	Vertical Round High Wind
VDV-CC33	Vertical Square Cap
VDV-CTT04	3" Co-linear to Coax Adapter
VDV-CAC04	4" Co-linear Appliance Adapter

SELKIRK PARTS LIST

PRODUCT NUMBER	PART	DESCRIPTION
4" x 6 5/8" ADAPTERS		
1604245B	4DT-AA	Appliance Adapter Black
4" x 6 5/8" TERMINATIONS AND FLASHINGS		
1604802	4DT-VC	High Wind Vertical Cap
1604804	4DT-HC	Horizontal Cap
1604810	4DT-SC	Storm Collar
2003949	4DT-HCR	Horizontal Round Termination Cap
KITS		
Co-Linear Components		
1604650	4DT-CTB	Co-Linear Termination Box with Baseplate
1604655	4DT-AAC	Co-Linear Appliance Adapter
1604085	4DT-CFC	Co-Linear Flex Connector

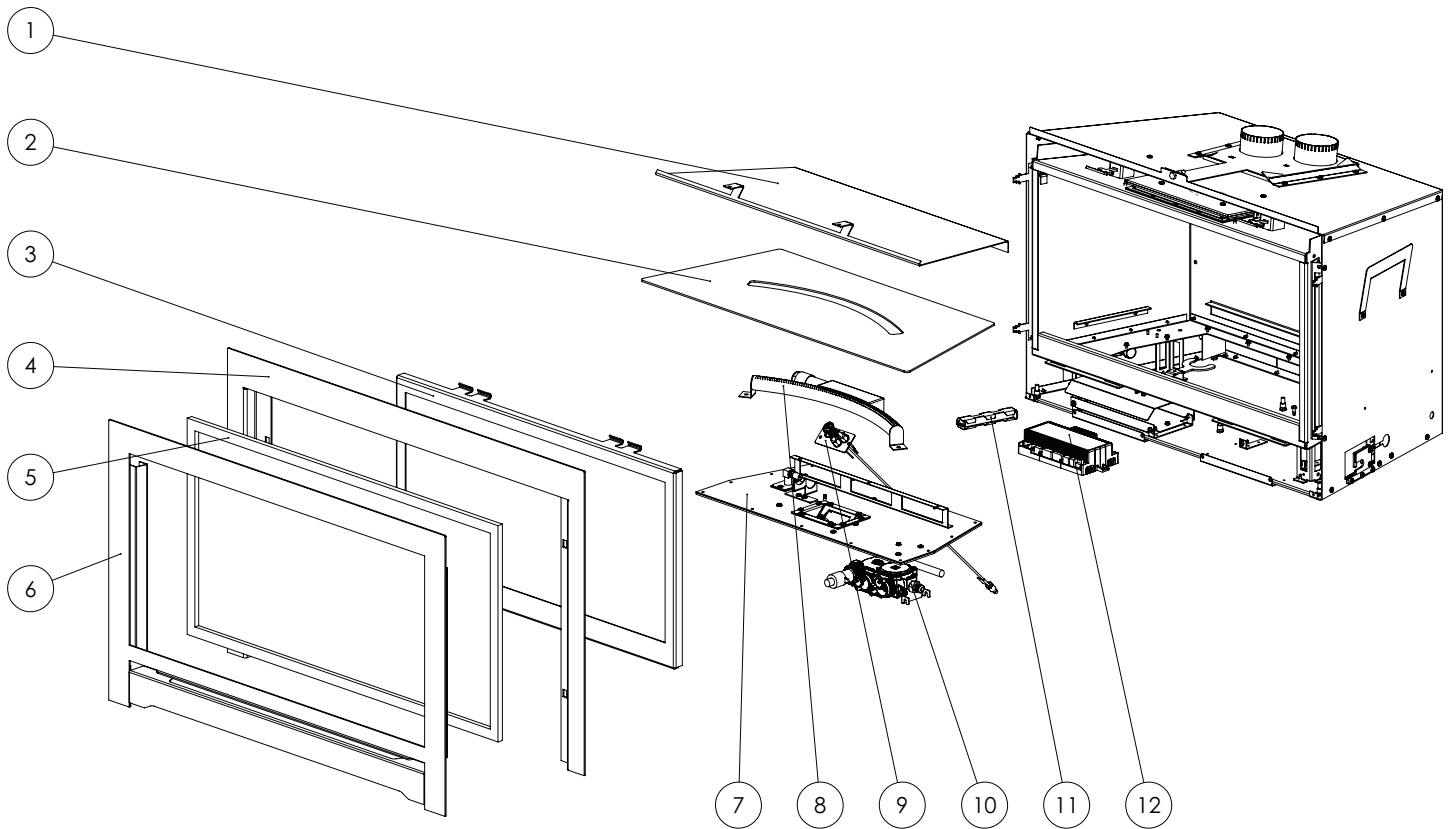

ITEM NO.	PART NUMBER	DESCRIPTION
1	4911	BAFFLE
2	Z4910	FLOOR PLATE ASSEMBLY
3	Z4917	CL2714 DOOR ASSEMBLY
4	4980	SECONDARY TRIM
5	645-1630	SAFETY SCREEN 16" X 30.5"
6	S.Z4921	SAFETY SCREEN TRIM w/ SCREEN
7	Z4927	VALVE ASSEMBLY WITH BURNER
8	640-4900	14" WIDE BURNER
9	610-199-059	PF2 PILOT ASSEMBLY
10	600-885-809	IPI VALVE WITH STEPPER MOTOR
11	140-5006	BATTERY HOLDER 4-AA, 6V
12	600-584-665	IFC BOARD

DIAGNOSTIC FLASH CODES ON IFC CONTROL

1. Failure to ignite: If there is no positive ignition, the board will go into lock out and the LED will flash three times in intervals until the system is reset.
2. Low battery condition (<4V): the LED indicator will flash one time in intervals.
3. Parasitic Pilot Flame: the LED indicator will flash two times in intervals.
4. System Lock out: the LED indicator will flash three times in intervals.

Additional Ignition Information

1. The Proflame2 IFC will try two times for ignition.
2. Each try for ignition will last approximately 60 seconds.
3. The wait time between the two tries is approximately 35 seconds

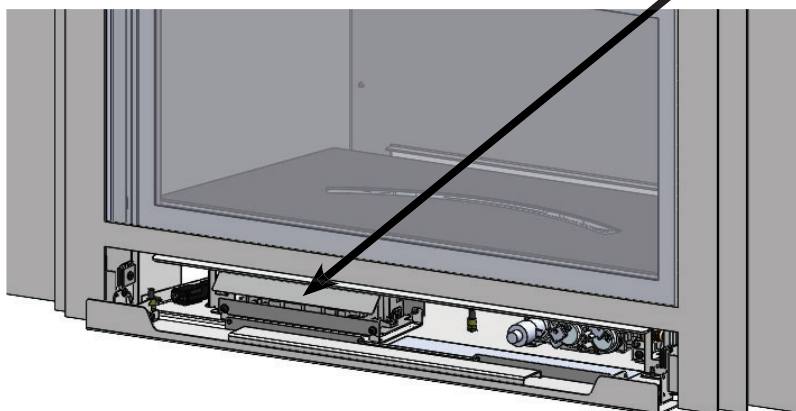
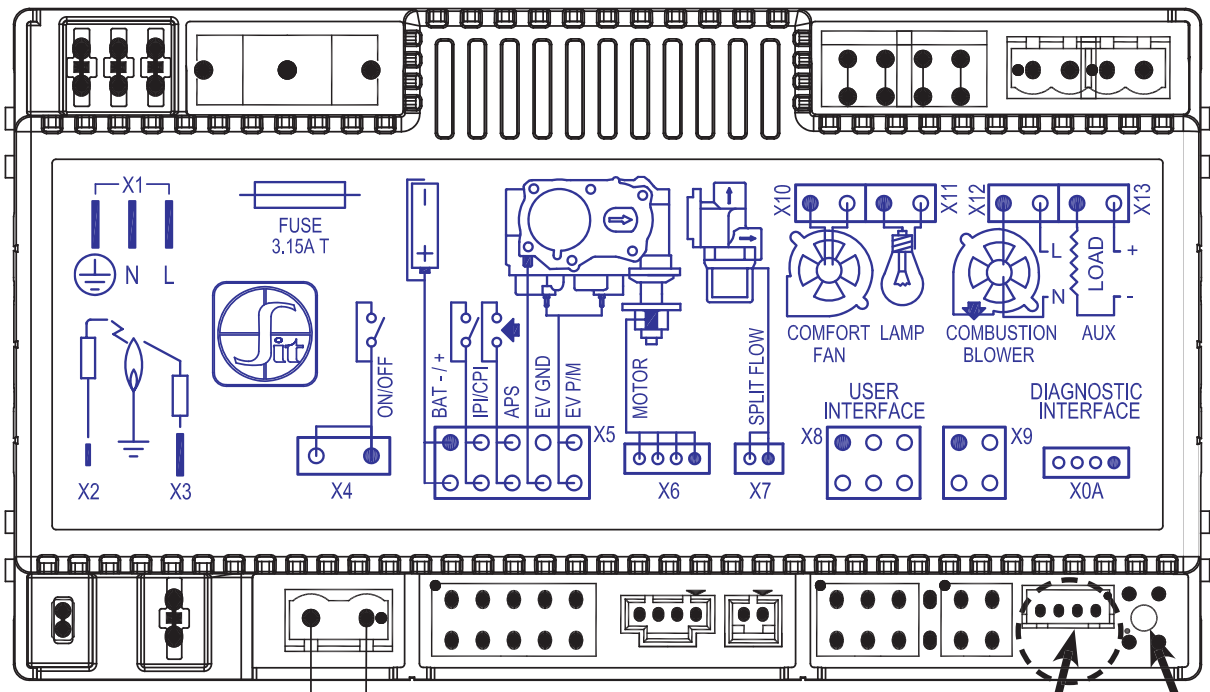

LED LOCATION **SYNC BUTTON**

Please ensure instructions were followed exactly before attempting to trouble shoot the appliance. Troubleshooting and servicing of the gas and electrical components of the appliance should be conducted by a qualified service person.

PROBLEM	POSSIBLE CAUSE	ACTION
Thermostat does not work	The pilot flame has gone out The On/Off switch is turn to OFF	<ul style="list-style-type: none"> • Turn it ON
	The thermostat is set too high	<ul style="list-style-type: none"> • The thermostat is set too high
No spark generation	Spark develops near the pilot assembly or could occur onboard	<ul style="list-style-type: none"> • Check pilot assembly wiring
		<ul style="list-style-type: none"> • Check for broken or poor connection from the sparker to the electrode
		<ul style="list-style-type: none"> • Check for the spark shorting or arcing at other locations
		<ul style="list-style-type: none"> • Check for defective sparker and spark electrode
No pilot flame ignition	No spark from the igniter	<ul style="list-style-type: none"> • See “no spark generation”
	Air in the gas line	<ul style="list-style-type: none"> • It takes a while for all the air to purge out of the pilot before gas can reach the pilot and ignite
	Pilot gas pressure dropout upon main burner gas valve opening	<ul style="list-style-type: none"> • Check gas mains supply and pressure
	No gas flow out of the pilot burner	<ul style="list-style-type: none"> • Check gas valve wirings and connections to the board • Check the pilot burner for obstruction • Check the wirings and connections between the pilot assembly and the board • Check the correct gas type settings on the valve and pilot burner assembly orifice
Pilot will not remain lit	Problem with Flame Sensor circuit	<ul style="list-style-type: none"> • Check for proper connection of the Flame Sensor to the IFC board • Check pilot for full flame impingement around Flame Sensor • If flame is too small, check gas pressure, adjust pilot rate screw, check pilot head for damage • Ensure the ground wire is properly attached to the pilot mounting bracket and that it makes a good electrical connection.
	Restrictor setting	<ul style="list-style-type: none"> • Use the correct restrictor setting for the venting configuration
Remote control does not work	The pilot light has gone out	<ul style="list-style-type: none"> • See “Pilot will not remain lit”
	The remote is too far away from the heater	<ul style="list-style-type: none"> • Use the remote closer to the heater
	One of the remote control batteries are dead	<ul style="list-style-type: none"> • Replace the batteries
No reaction to command	IFC or transmitter batteries are low	<ul style="list-style-type: none"> • Replace the batteries
	A maximum number of failed ignitions or flame restorations have been reached	<ul style="list-style-type: none"> • Remove any possible blocking conditions. See “locking conditions” • See how to reset the board from Lockout
	No communication between the remote control and the IFC	<ul style="list-style-type: none"> • Reprogram the transmitter to the IFC. • Follow the initializing system for the first time

Locking conditions	Reset the Proflame IFC board	<ul style="list-style-type: none"> Turn the system off by pressing the ON/OFF button on the transmitter After approximately 2 seconds press the ON/OFF button on the transmitter again.
		<ul style="list-style-type: none"> In the manual flame control mode, use the down arrow button to reduce the flame to off, indicated by the word OFF displayed on the transmitter LCD screen. Wait approximately 2 seconds and press the up arrow button, the ignition sequence will start.
Main burners will not start	The pilot flame has gone out	<ul style="list-style-type: none"> See "Pilot will not remain lit"
	The remote control is not working correctly	<ul style="list-style-type: none"> Replace the batteries
	The thermostat is disconnected or set too high	<ul style="list-style-type: none"> Set the thermostat to a lower temperature
	Problem with thermopile circuit	<ul style="list-style-type: none"> Check gas line pressure Check wiring to thermostat for breaks Check for flame impingement on thermopile
Flame lifting	Leak in vent pipe	<ul style="list-style-type: none"> Check for leaks in vent connections
	Improper vent configuration	<ul style="list-style-type: none"> Check vent configuration with manual
	Terminal may be re-circulating flue gases	<ul style="list-style-type: none"> Check to see if terminal is on correctly May need to install high wind termination cap. Contact dealer
Blue Flames	The heater has just been started	<ul style="list-style-type: none"> Normal during start up: flame will yellow as the fireplace heats up
	Improper air shutter adjustment	<ul style="list-style-type: none"> Adjust air shutter – contact your dealer
Glass fogs up	Normal condition: after the appliance warms up the glass will be clear.	<ul style="list-style-type: none"> **Due to additives in gas, glass may get hazy during operation** Clean as needed.
Flames are burning "dirty" or sooting	Optional logs are placed incorrectly	<ul style="list-style-type: none"> Check that logs do not impinge on the flame, see manual pictures.
	Improper air shutter adjustment	<ul style="list-style-type: none"> Increase primary air by opening the air shutter and/or by opening the vent restrictor Check for proper venting and blockage of the vent termination See also "Burners will not remain lit"
	Incorrect rating input	<ul style="list-style-type: none"> Check manifold pressure and clock input rating for over-firing

WARRANTY

BLAZE KING GAS LIMITED WARRANTY

Blaze King and Valley Comfort's respective brands extend the following warranty for gas appliances purchased from an authorized Blaze King / Valley Comfort dealer and installed in the United States of America or Canada. Warranty starts with date of purchase by the original owner (End User) except as noted for replacement parts.

Warranty Period		Components Covered	
Parts	Labor	Gas	
1 Year		X	All parts, materials and surface finishes (flaking and peeling). Except as covered by Conditions Exclusion, and Limitations listed.
2 Years Parts 1 Year Labor		X	Igniters, thermocouple, thermopile molded refractory panels, log sets, interior glass panels, fan assembly, ignition components, gas valve, burner components, thermostat.
5 Years	2 Years	X	Firebox & Heat Exchanger
10 Years	2 Years	X	All exterior steel cabinets (excluding paint finishes) Door glass (thermal breakage only)
1 Year		X	Other Replacement Parts
See Conditions, Exclusions, and Limitations			

Blaze King Gas Limited 10 Year Warranty

Blaze King is the manufacturer of the Blaze King line of heating products. At Blaze King, our commitment to the highest level of quality and customer service is the most important thing we do. Each Blaze King stove is built on a tradition of using only the finest materials and is backed by our limited lifetime warranty to the original purchaser. With Blaze King, you're not just buying a fireplace or stove, you're buying a company with years of unequalled performance and quality.

Limited 10 Year Warranty:

Under this warranty, Blaze King covers the fireplace or stove, exterior body, pedestals, legs and glass (thermal breakage only) against defects in materials and workmanship, for part repair or replacement for (10) years from original purchase date and limited labor for the first two (2) years to the original purchaser. This warranty does not cover exterior finishes. Please see the exclusions and limitation section below as certain restrictions and exclusions apply to this warranty.

Limited 5 Year Warranty:

Under this warranty, Blaze King covers the fireplace or stove firebox and heat exchanger against defects in materials and workmanship, for part repair or replacement for the first five (5) years and limited labor for the first two (2) years to the original purchaser. This Warranty covers: Heat Exchanger, Steel Firebox Panels and any steel components not covered under the ten (10) year Warranty excluding burner components and gas components. Please see the exclusions and limitation section below as certain restrictions and exclusions apply to this warranty.

Limited Two (2) Year Warranty:

Under this warranty, Blaze King covers: Gas Assembly, Burner components (ceramic and steel), Log sets, Blower and control, Temperature Sensors, thermocouple, thermopile, electronic ignition components and wire harness against defects in materials and workmanship, for part repair or replacement for the first two (2) years and limited labor for the first (1) year to the original purchaser. Please see the exclusions and limitation section below as certain restrictions and exclusions apply to this warranty.

Limited One (1) Year Warranty:

Under this warranty, Blaze King covers all exterior surface finishes against defects in materials and workmanship, for part repair or replacement and limited labor for the first (1) year to the original purchaser. Please see the exclusions and limitations section below as certain restrictions and exclusions apply to this warranty.

How the Warranty Works (Includes Conditions, Exclusions and Limitations)

1. All warranties by the manufacturer are set herein and no claim shall be made against the manufacturer on any oral warranty or representation. All claims under this Limited Warranty must be made in writing by your dealer.
2. Any stove or part thereof that is repaired or replaced during the Limited Warranty period will be warranted under the terms of the Limited Warranty for a period not exceeding the remaining term of the original Limited Warranty or six (6) months, whichever is longer.
3. For any part or parts of this stove, which in our judgment show evidence of defects, Blaze King reserves the option to repair or to replace the defective product through an accredited distributor or agent, provided the defective part is returned to the distributor or agent, transportation prepaid, if requested.
4. If you discover a problem that you think may be covered by the Limited Warranty, you **MUST REPORT** it to your Blaze King dealer **WITHIN 30 DAYS** from the date the problem was first detected, giving them proof of purchase and the date of purchase. The dealer will investigate the problem and work with Blaze King to determine whether the problem:
 - a) Is covered by the Limited Warranty or
 - b) Can be fixed in your home or does the product need to be returned to Blaze King for repair.
5. If Blaze King determines that the stove needs to be returned to Blaze King for repair, the customer has the responsibility and the expense of removing it from their home and shipping it to Blaze King. If the problem is covered by the Warranty, Blaze King will repair or replace the item at their discretion and the customer will be responsible for return shipping and re-installation in their home.
6. If the problem is not covered by the Limited Warranty, the customer will be responsible for all repair costs, as well as all storage, shipping and the cost of removing and re-installing the stove.

If you are not satisfied with the service provided by the Blaze King dealer, write to Blaze King at the address listed on the last page of the Owner's Manual. Include a copy of the original purchase invoice and a description of the problem.

Exclusions and Limitations:

1. This Warranty does not cover tarnish, discoloration or wear on the plated surfaces. Painted finishes will change colour after initial firing and will continue to change through the lifetime of the stove. This is normal occurrence for all high temperature coatings.
2. This Warranty excludes wear and tear or breakage caused by cleaning, moving or service on log set and panels.
3. Blaze King strongly recommends that installation be done by a certified installer. Failure to comply may adversely affect coverage under this warranty. This Limited Warranty covers defects in materials and workmanship only if the product has been installed in accordance with local building and fire codes; in their absence, refer to the owner's manual. If the product is damaged or broken as a result of any alteration, wilful abuse, mishandling, accident, neglect, or misuse of the product, the Limited Warranty does not apply.
4. The stove must be operated and maintained at all times in accordance with the instructions in the Owner's Manual. If the unit shows signs of neglect or misuse, it is not covered under the terms of this Warranty policy. Performance problems due to operator error will not be covered by the Limited Warranty policy.
5. Some minor expansion, contraction, or movement of certain parts and resulting noise, is normal and not a defect and, therefore, is not covered under this Limited Warranty.
6. Misuse includes over-firing. Over-firing this appliance can cause serious damage and will nullify the Limited Warranty.
7. The Limited Warranty will cover glass thermal breakage only and will not cover misuse of the stove glass, including but not limited to glass that is struck, has surface contaminates or has had harsh or abrasive cleaners used on it.
8. This warranty does not cover products made or provided by other manufacturers and used in conjunction with the operation of this stove without prior authorization from Blaze King. The use of such products may nullify the Limited Warranty on this stove. If unsure as to the extent of this Limited Warranty, contact your authorized Blaze King dealer before installation.
9. Blaze King will not be responsible for inadequate performance caused by environmental conditions.
10. The Limited Warranty does not cover installation and operational related problems such as use of downdrafts or spillage caused by environmental conditions. Environmental conditions include but are not limited to nearby trees, buildings, roof tops, wind, hills, mountains, inadequate venting or ventilation, excessive offsets, negative air pressures or other influences caused by mechanical systems such as furnaces, fans, clothes dryers etc.
11. The Limited Warranty is void if:
 - a) The stove has been operated in atmospheres contaminated by chlorine, fluorine or other damaging chemicals.
 - b) The stove is subject to submersion in water or prolonged periods of dampness or condensation.
 - c) Any damage to the unit, combustion chamber or other components due to water, or weather damage which is the result of, but not limited to, improper chimney/venting installation.
 - d) Salt air in coastal areas or high humidity can be corrosive to the finish; these environmental can cause rusting. Damage caused by salt air or high humidity is not covered by the Limited Warranty.
12. Exclusions to the Limited Warranty include: injury, loss of use, damage, failure to function due to accident, negligence, misuse, improper installation, alteration or adjustment of the manufacturer's settings of components, lack of proper and regular maintenance, alteration, or act of God.
13. The Limited Warranty does not cover damage caused to the fireplace or stove while in transit. If this occurs, do not operate the stove and contact your courier and/or dealer.
14. Limited Warranty does not extend to or include firebox paint, door or glass gaskets with damage caused by normal wear and tear, or exterior paint discoloration or chipping, worn gaskets, etc.
15. The Limited Warranty does not include damage to the unit caused by abuse, improper installation, or modification of the unit.
16. Damage to plated surfaces caused by fingerprints, scratches, melted items, or other external scores and residues left on the plated surfaces from the use of abrasive cleaners or polishes is not covered in this warranty.
17. The paint on the brick liner may peel. It is not a flaw and is not covered under warranty, due to extreme conditions in the firebox.
18. Blaze King is free of liability for any damages caused by the fireplace or stove, as well as inconvenience expenses and materials. The Limited Warranty does not cover incidental or consequential damages.

19. The Limited Warranty does not cover any loss or damage incurred by the use or removal of any component or apparatus to or from the Blaze King fireplace or stove without the express written permission of Blaze King and bearing a Blaze King label of approval.
20. Any statement or representation of Blaze King Products and their performance contained in Blaze King advertising, packaging literature, or printed material is not part of the Limited Warranty.
21. The Limited Warranty is automatically voided if the fireplace or stove's serial number has been removed or altered in any way. If the stove is used for commercial purposes, it is excluded from the Limited Warranty.
22. No dealer, distributor, or similar person has the authority to represent or warrant Blaze King Products beyond the terms contained within the Limited Warranty. Blaze King assumes no liability for such warranties or representations.
23. Blaze King will not cover the cost of the removal or re-installation of the stove, hearth, facing, mantels, venting or other components.
24. Labor to replace or repair items under this Limited Warranty will be covered per our warranty service fee reimbursement schedule. Labor rates are set per component and as such total labor costs may not be covered.
25. If a defect or problem is determined by Blaze King to be non-warrantable, Blaze King will not be liable for travel costs for service work. In the event of in-home repair work, the customer will pay any in-home travel fees or service charges required by the Authorized Dealer.
26. At no time will Blaze King be liable for any consequential damages which exceed the purchase price of the unit. Blaze King has no obligation to enhance or modify any stove once manufactured (example: as a stove model evolves, field modifications or upgrades will not be performed).
27. This Limited Warranty is applicable only to the original purchaser and it is non-transferable.
28. This warranty only covers Blaze King Products that are purchased through an authorized Blaze King dealer.
29. If for any reason any section of the Limited Warranty is declared invalid, the balance of the warranty remains in effect and all other clauses shall remain in effect.
30. The Limited Warranty is the only warranty supplied by Blaze King, the manufacturer of the stove. All other warranties, whether express or implied, are hereby expressly disclaimed and purchaser's recourse is expressly limited to the Limited Warranty.
31. Blaze King and its employees or representatives will not assume any damages, either directly or indirectly, caused by improper usage, operation, installation, servicing or maintenance of this stove.
32. Blaze King reserves the right to make changes without notice. Please complete and mail the warranty registration card and have the installer fill in the installation data sheet in the back of the manual for warranty and future reference.
33. Blaze King is responsible for stocking parts for a maximum of seven (7) years after discontinuing the manufacture or incorporation of the item into its products. An exception to this would be if an OEM supplier is not able to supply a part.

NOTES

Installer - Please complete the following information:

Dealer Name & Address: _____

Installer Name (print): _____

Installer Signature: _____

Installer Phone #: _____

Date Installed: _____

Appliance Serial No.: _____